

## 1290 Super Adventure

Art. no. 3206220en



**KTM**



Read this repair manual carefully and thoroughly before beginning work.

The vehicle will only be able to meet the demands placed on it if the specified service work is performed regularly and properly.

This repair manual was written to correspond to the latest state of this model series. We reserve the right to make changes in the interest of technical advancement without updating this repair manual at the same time.

We shall not provide a description of general workshop methods. Likewise, safety rules that apply in a workshop are not specified here. It is assumed that the repair work will be performed by a fully trained mechanic.

All specifications are non-binding. KTM Sportmotorcycle GmbH specifically reserves the right to modify or delete technical specifications, prices, colors, forms, materials, services, designs, equipment, etc., without prior notice and without specifying reasons, to adapt these to local conditions, as well as to stop production of a particular model without prior notice. KTM accepts no liability for delivery options, deviations from illustrations and descriptions, misprints, and other errors. The models portrayed partly contain special equipment that does not belong to the regular scope of supply.

© 2017 KTM Sportmotorcycle GmbH, Mattighofen Austria

All rights reserved

Reproduction, even in part, as well as copying of all kinds, is permitted only with the express written permission of the copyright owner.



ISO 9001(12 100 6061)

According to the international quality management standard ISO 9001, KTM uses quality assurance processes that lead to the maximum possible quality of the products.

Issued by: TÜV Management Service

REG.NO. 12 100 6061

KTM Sportmotorcycle GmbH  
5230 Mattighofen, Austria

This document is valid for the following models:

1290 Super Adventure EU (F99030A)

1290 Super Adventure FR (F99230A)

1290 Super Adventure AU (F99600A)

1290 Super Adventure JP (F99860A)

1290 Super Adventure US (F99750A)

1290 Super Adventure CN (F99870A)



# TABLE OF CONTENTS

1	MEANS OF REPRESENTATION .....	6	8.4	Installing the engine guard .....	43
1.1	Symbols used .....	6	8.5	Checking the frame .....	44
1.2	Formats used.....	6	9	SHOCK ABSORBER, SWINGARM .....	45
2	SAFETY ADVICE.....	7	9.1	Measuring the rear wheel dimension unloaded.....	45
2.1	Repair Manual .....	7	9.2	Checking the static sag of the shock absorber ....	45
2.2	Safety advice.....	7	9.3	Adjusting the spring pretension of the shock absorber.....	45
2.3	Degrees of risk and symbols .....	7	9.4	Removing the shock absorber .....	46
2.4	Work rules.....	7	9.5	Installing the shock absorber.....	47
3	IMPORTANT NOTES.....	8	9.6	Removing the spring.....	48
3.1	Warranty .....	8	9.7	Installing the spring .....	49
3.2	Operating and auxiliary substances .....	8	9.8	Removing the heim joint.....	50
3.3	Spare parts, accessories .....	8	9.9	Installing the heim joint.....	50
3.4	Figures .....	8	9.10	Checking the swingarm.....	51
4	SERIAL NUMBERS .....	9	9.11	Checking the swingarm bearing for play .....	51
4.1	Chassis number .....	9	9.12	Removing the swingarm.....	52
4.2	Type label .....	9	9.13	Changing the swingarm bearing.....	54
4.3	Key number.....	9	9.14	Installing the swingarm.....	57
4.4	Engine number .....	10	9.15	Programming the shock absorber control motor.....	59
4.5	Fork part number .....	10	9.16	Programming the swing angle sensor.....	59
4.6	Shock absorber article number .....	10	10	EXHAUST .....	60
4.7	Steering damper item number .....	10	10.1	Disassembling the main silencer .....	60
5	MOTORCYCLE .....	11	10.2	Installing the main silencer.....	60
5.1	Lifting the motorcycle with the front lifting gear .....	11	10.3	Removing the manifold.....	61
5.2	Taking the motorcycle from the front lifting gear .....	11	10.4	Installing the manifold .....	63
5.3	Raising the motorcycle with the rear lifting gear .....	11	11	AIR FILTER .....	66
5.4	Removing the rear of motorcycle from the lifting gear .....	12	11.1	Removing the upper part of the air filter box.....	66
5.5	Raising the vehicle with the center stand .....	12	11.2	Changing the air filter, cleaning the air filter box .....	66
5.6	Removing the vehicle from the center stand .....	12	11.3	Installing the upper part of the air filter box.....	67
5.7	Starting.....	13	11.4	Removing the lower part of the air filter box.....	68
5.8	Starting the motorcycle to check the function ....	13	11.5	Installing the lower part of the air filter box .....	69
6	FORK, TRIPLE CLAMP .....	14	12	FUEL TANK, SEAT, TRIM .....	71
6.1	Cleaning the dust boots of the fork legs.....	14	12.1	Adjusting the front rider's seat.....	71
6.2	Removing the fork legs .....	14	12.2	Removing the front rider's seat .....	71
6.3	Installing the fork legs.....	15	12.3	Mounting the front rider's seat.....	71
6.4	Performing a fork service .....	16	12.4	Removing the passenger seat .....	72
6.5	Disassembling the fork legs.....	17	12.5	Mounting the passenger seat.....	72
6.6	Removing the spring.....	19	12.6	Removing the fuel tank.....	73
6.7	Installing the spring .....	19	12.7	Installing the fuel tank .....	74
6.8	Checking the fork legs .....	20	12.8	Checking the fuel pressure.....	76
6.9	Assembling the fork legs.....	21	12.9	Changing the fuel pump .....	77
6.10	Checking the steering head bearing play.....	24	12.10	Changing the fuel filter .....	80
6.11	Adjusting the steering head bearing play .....	24	13	MASK, FENDER, DECAL.....	87
6.12	Lubricating the steering head bearing .....	25	13.1	Removing the front side cover .....	87
6.13	Removing the lower triple clamp.....	25	13.2	Installing the front side cover .....	87
6.14	Installing the lower triple clamp .....	26	13.3	Removing the tank cover.....	89
6.15	Changing the steering head bearing .....	28	13.4	Installing the tank cover .....	89
6.16	Changing the steering damper .....	29	13.5	Removing the mask spoiler .....	90
7	HANDLEBAR, CONTROLS.....	31	13.6	Installing the mask spoiler .....	92
7.1	Adjusting basic position of clutch lever .....	31	13.7	Removing the bottom triple clamp cover.....	93
7.2	Adjusting the handlebar position .....	31	13.8	Installing the bottom triple clamp cover .....	93
7.3	Removing the crash bar .....	32	13.9	Removing the front fender .....	94
7.4	Installing the crash bar.....	32	13.10	Installing the front fender .....	94
7.5	Changing the throttle grip .....	33	13.11	Removing the wind shield .....	94
7.6	Replacing the heated grips .....	36	13.12	Installing the wind shield.....	95
8	FRAME .....	42	13.13	Adjusting the wind shield .....	95
8.1	Rider footrests.....	42	13.14	Adjusting the windshield adapter position .....	95
8.2	Adjusting the footrests.....	42	14	WHEELS .....	97
8.3	Removing the engine guard.....	43	14.1	Checking the tire air pressure.....	97

14.2	Checking the tire condition .....	97	17	LIGHTING SYSTEM, INSTRUMENTS .....	145
14.3	Checking the rim run-out .....	98	17.1	Removing the headlight mask with the headlight.....	145
14.4	Checking the wheel bearing for play.....	98	17.2	Installing the headlight mask with the headlight.....	145
14.5	Checking spoke tension .....	99	17.3	Changing the low beam bulb .....	146
14.6	Programming the tire pressure sensor .....	99	17.4	Changing the high beam bulb.....	147
14.7	Front wheel .....	99	17.5	Checking the setting of the lighting system.....	148
14.7.1	Removing the front wheel .....	99	17.6	Adjusting the headlight range.....	149
14.7.2	Installing the front wheel .....	100	17.7	Adjusting the cornering light range .....	149
14.7.3	Changing the front wheel bearing .....	101	17.8	Activating/deactivating the ignition key .....	150
14.7.4	Tubeless tire system.....	103	17.9	Programming the switch for the cruise control system .....	152
14.7.5	Changing the front tubeless sealing profile.....	103	17.10	Resetting the service display using the KTM diagnostic tool .....	153
14.7.6	Changing the front tire pressure sensor .....	105	18	ENGINE .....	154
14.7.7	Checking the brake discs .....	106	18.1	Removing the engine.....	154
14.7.8	Changing the front brake discs.....	107	18.2	Installing the engine.....	160
14.8	Rear wheel .....	107	18.3	Preparing the engine for installation .....	168
14.8.1	Removing the rear wheel .....	107	18.4	Preparing the engine for clamping in the engine assembly stand .....	168
14.8.2	Installing the rear wheel .....	108	18.5	Setting the engine to ignition top dead center of the rear cylinder.....	169
14.8.3	Changing the rear wheel bearing.....	109	18.6	Setting the engine to ignition top dead center of the front cylinder.....	169
14.8.4	Changing the rear tubeless sealing profile ...	111	18.7	Engine disassembly.....	170
14.8.5	Changing the rear tire pressure sensor.....	113	18.7.1	Clamping the engine into the engine assembly stand.....	170
14.8.6	Changing the rear brake discs .....	114	18.7.2	Removing the engine bearer.....	170
14.8.7	Checking the chain tension.....	115	18.7.3	Draining the engine oil .....	170
14.8.8	Adjusting the chain tension .....	115	18.7.4	Removing the front valve cover.....	171
14.8.9	Checking the chain, rear sprocket and engine sprocket .....	116	18.7.5	Removing the rear valve cover.....	171
14.8.10	Cleaning the chain .....	117	18.7.6	Setting the engine to ignition top dead center of the rear cylinder.....	171
14.8.11	Checking the rear hub rubber dampers.....	118	18.7.7	Removing the starter motor .....	172
14.8.12	Changing the rubber dampers in the rear hub .....	118	18.7.8	Removing the oil filler tube.....	172
14.8.13	Changing the bearing of the rear sprocket carrier.....	119	18.7.9	Removing the heat exchanger.....	172
14.8.14	Opening the chain .....	120	18.7.10	Removing the rear timing chain tensioner....	172
14.8.15	Riveting the chain.....	120	18.7.11	Removing the rear camshaft.....	173
14.8.16	Changing the drivetrain kit.....	121	18.7.12	Removing the rear cylinder head .....	173
15	WIRING HARNESS, BATTERY.....	125	18.7.13	Removing the rear piston .....	174
15.1	Removing the battery .....	125	18.7.14	Setting the engine to ignition top dead center of the front cylinder .....	174
15.2	Installing the battery .....	125	18.7.15	Removing the front timing chain tensioner.....	174
15.3	Disconnecting the negative (minus) cable of the battery .....	126	18.7.16	Removing the front camshafts.....	175
15.4	Connecting the negative cable of the battery....	127	18.7.17	Removing the front cylinder head .....	175
15.5	Recharging the battery .....	128	18.7.18	Removing the front piston.....	176
15.6	Changing the main fuse.....	129	18.7.19	Removing the alternator cover.....	176
15.7	Changing the fuses in the fuse box .....	130	18.7.20	Removing the ignition pulse generator .....	177
15.8	Checking the charging voltage .....	132	18.7.21	Removing the torque limiter.....	177
15.9	Checking the open-circuit current.....	133	18.7.22	Removing the rotor.....	177
16	BRAKE SYSTEM .....	134	18.7.23	Removing the idler and timing chain on the left .....	177
16.1	Checking the front brake linings .....	134	18.7.24	Removing the oil filter.....	178
16.2	Changing the front brake linings.....	134	18.7.25	Removing the balancer shaft.....	179
16.3	Checking the brake fluid level of the front brake .....	136	18.7.26	Removing the drive wheel of the balancer shaft.....	179
16.4	Adding front brake fluid.....	136	18.7.27	Removing the gear position sensor.....	179
16.5	Changing the front brake fluid.....	137	18.7.28	Removing the left suction pump.....	179
16.6	Adjusting the basic position of the hand brake lever .....	139	18.7.29	Removing the water pump wheel .....	180
16.7	Checking the rear brake linings .....	139	18.7.30	Removing the clutch cover.....	181
16.8	Changing the rear brake linings .....	139	18.7.31	Removing the clutch discs.....	181
16.9	Adjusting the basic position of the foot brake lever .....	141			
16.10	Checking the rear brake fluid level.....	142			
16.11	Adding rear brake fluid.....	142			
16.12	Changing the rear brake fluid .....	143			

18.7.32	Removing the clutch basket.....	182	18.9.3	Installing the oil spray tube.....	218
18.7.33	Removing the idler and timing chain on the right.....	183	18.9.4	Installing the transmission shaft.....	218
18.7.34	Removing the primary gear .....	183	18.9.5	Installing the middle suction pump .....	219
18.7.35	Removing the force pump.....	183	18.9.6	Installing the crankshaft .....	219
18.7.36	Removing the shift shaft.....	184	18.9.7	Installing the left engine case .....	219
18.7.37	Removing the shift drum locating.....	184	18.9.8	Installing the locking lever .....	221
18.7.38	Removing the locking lever .....	184	18.9.9	Installing the shift drum locating.....	221
18.7.39	Removing the left engine case.....	185	18.9.10	Installing the shift shaft .....	221
18.7.40	Removing the crankshaft .....	185	18.9.11	Installing the force pump.....	221
18.7.41	Removing the middle suction pump.....	185	18.9.12	Installing the left suction pump.....	222
18.7.42	Removing the transmission shaft .....	186	18.9.13	Setting the engine to ignition top dead center of the rear cylinder.....	223
18.7.43	Removing the oil spray tube.....	187	18.9.14	Installing the primary gear .....	223
18.7.44	Removing the timing chain rails of the right engine case section .....	187	18.9.15	Installing the clutch basket.....	223
18.7.45	Removing the timing chain rails of the left engine case section.....	187	18.9.16	Installing the clutch discs.....	224
18.8	Working on individual parts.....	187	18.9.17	Installing the idler and timing chain on the right .....	225
18.8.1	Work on the right section of the engine case .....	187	18.9.18	Installing the clutch cover .....	225
18.8.2	Removing the right main bearing.....	189	18.9.19	Installing the water pump wheel.....	226
18.8.3	Selecting the main bearing shells .....	190	18.9.20	Installing the gear position sensor .....	227
18.8.4	Installing the right main bearing.....	190	18.9.21	Installing the drive wheel of the balancer shaft.....	227
18.8.5	Work on the left section of the engine case .....	191	18.9.22	Installing the balancer shaft.....	227
18.8.6	Removing the left main bearing.....	193	18.9.23	Installing the idler and timing chain on the left .....	228
18.8.7	Installing the left main bearing .....	193	18.9.24	Installing the oil filter.....	228
18.8.8	Changing the conrod bearing.....	194	18.9.25	Installing the rotor .....	229
18.8.9	Work on the clutch cover .....	196	18.9.26	Installing the torque limiter .....	229
18.8.10	Changing the support bearing of the crankshaft.....	197	18.9.27	Installing the ignition pulse generator .....	230
18.8.11	Checking the radial clearance of the bottom connecting rod bearing.....	197	18.9.28	Installing the alternator cover.....	230
18.8.12	Checking/measuring the cylinder .....	198	18.9.29	Rear piston assembly .....	230
18.8.13	Checking/measuring the piston.....	199	18.9.30	Installing the rear cylinder head .....	232
18.8.14	Checking the piston ring end gap .....	200	18.9.31	Installing the rear camshafts.....	233
18.8.15	Checking the piston/cylinder mounting clearance .....	200	18.9.32	Installing the rear timing chain tensioner ...	233
18.8.16	Work on the cylinder head .....	200	18.9.33	Setting the engine to ignition top dead center of the front cylinder .....	234
18.8.17	Checking the cylinder head.....	203	18.9.34	Installing the front piston .....	234
18.8.18	Work on the right idler.....	205	18.9.35	Installing the front cylinder head.....	236
18.8.19	Checking the timing assembly.....	205	18.9.36	Installing the front camshafts.....	236
18.8.20	Preparing the timing chain tensioner for installation.....	206	18.9.37	Installing the front timing chain tensioner ...	237
18.8.21	Pretensioning the spread transmission .....	206	18.9.38	Installing the heat exchanger .....	237
18.8.22	Checking the oil pressure regulator valve....	207	18.9.39	Installing the starter motor.....	238
18.8.23	Checking the lubrication system.....	207	18.9.40	Checking the rear valve clearance.....	238
18.8.24	Checking the clutch .....	208	18.9.41	Adjusting the rear valve clearance .....	238
18.8.25	Checking the shift mechanism .....	209	18.9.42	Checking the front valve clearance.....	238
18.8.26	Preassembling the shift shaft.....	210	18.9.43	Adjusting the front valve clearance .....	239
18.8.27	Disassembling the main shaft .....	211	18.9.44	Installing the oil filler tube .....	239
18.8.28	Disassembling the countershaft.....	212	18.9.45	Installing front valve cover .....	240
18.8.29	Checking the transmission .....	213	18.9.46	Installing rear valve cover .....	240
18.8.30	Assembling the main shaft.....	214	18.9.47	Installing the oil drain plug.....	241
18.8.31	Assembling the countershaft.....	214	18.9.48	Mounting the engine bearer .....	241
18.8.32	Measuring the main shaft axial play.....	216	18.9.49	Removing the engine from the engine assembly stand.....	241
18.8.33	Checking electric starter operation.....	216	19	SECONDARY AIR SYSTEM SAS.....	242
18.8.34	Checking the free-wheel .....	217	19.1	Changing the SAS membrane.....	242
18.9	Engine assembly.....	217	20	CLUTCH.....	244
18.9.1	Installing the timing chain rails of the left engine case section.....	217	20.1	Checking/rectifying the fluid level of the hydraulic clutch.....	244
18.9.2	Installing the timing chain rails of the right engine case section .....	217	20.2	Changing the hydraulic clutch fluid .....	244
			20.3	Checking the clutch .....	245
			21	SHIFT MECHANISM.....	251
			21.1	Checking the basic position of the shift lever ...	251

# TABLE OF CONTENTS

21.2	Adjusting the basic position of the shift lever .....	251	28	CLEANING/PROTECTIVE TREATMENT .....	305
21.3	Changing the gear position sensor.....	251	28.1	Cleaning motorcycle .....	305
21.4	Programming gear position sensor .....	253	28.2	Checks and maintenance steps for winter operation.....	306
22	WATER PUMP, COOLING SYSTEM .....	254	29	STORAGE.....	307
22.1	Checking the coolant level in the compensating tank.....	254	29.1	Storage .....	307
22.2	Correcting the coolant level in the compensating tank.....	254	29.2	Preparing for use after storage.....	307
22.3	Checking the coolant fill level and antifreeze ...	255	29.3	Checks and maintenance measures when preparing for use.....	307
22.4	Draining the coolant.....	256	30	SERVICE SCHEDULE .....	309
22.5	Adding coolant/bleeding the cooling system.....	257	30.1	Additional information.....	309
23	CYLINDER HEAD .....	259	30.2	Required work .....	309
23.1	Checking the valve clearance .....	259	30.3	Recommended work .....	310
23.2	Checking the valve clearance (air filter and spark plugs removed) .....	267	31	WIRING DIAGRAM .....	312
23.3	Setting the valve clearance of the rear cylinder.....	270	31.1	Page 1 of 13 .....	312
23.4	Setting the valve clearance of the front cylinder.....	271	31.2	Page 2 of 13 .....	314
23.5	Disassembling the camshafts of the rear cylinder.....	271	31.3	Page 3 of 13 .....	316
23.6	Installing the camshafts of the rear cylinder ....	272	31.4	Page 4 of 13 .....	318
23.7	Disassembling the camshafts of the front cylinder.....	273	31.5	Page 5 of 13 .....	320
23.8	Installing the camshafts of the front cylinder ...	273	31.6	Page 6 of 13 .....	322
24	LUBRICATION SYSTEM.....	275	31.7	Page 7 of 13 .....	324
24.1	Oil circuit.....	275	31.8	Page 8 of 13 .....	326
24.2	Checking the engine oil level.....	276	31.9	Page 9 of 13 .....	328
24.3	Changing the engine oil and filter, cleaning the oil screens .....	276	31.10	Page 10 of 13 .....	330
24.4	Adding engine oil.....	278	31.11	Page 11 of 13 .....	332
24.5	Checking the engine oil pressure .....	279	31.12	Page 12 of 13 .....	334
24.6	Removing the oil nozzle for the clutch lubrication.....	280	31.13	Page 13 of 13 .....	336
24.7	Checking/cleaning the oil nozzle for clutch lubrication.....	280	32	SUBSTANCES .....	338
24.8	Installing the oil nozzle for the clutch lubrication.....	281	33	AUXILIARY SUBSTANCES .....	340
25	IGNITION SYSTEM.....	282	34	SPECIAL TOOLS .....	342
25.1	Alternator - checking the stator winding .....	282	35	STANDARDS .....	358
25.2	Changing spark plugs (air filter removed).....	284		INDEX .....	359
26	THROTTLE VALVE BODY .....	292			
26.1	Removing the throttle valve body .....	292			
26.2	Installing the throttle valve body.....	293			
26.3	Executing the initialization run.....	294			
26.4	Checking the CO adjustment using the KTM diagnostics tool.....	295			
27	TECHNICAL DATA.....	296			
27.1	engine .....	296			
27.2	Tolerance, engine wear limits.....	296			
27.3	Engine tightening torques .....	299			
27.4	Capacities .....	300			
27.4.1	Engine oil .....	300			
27.4.2	Coolant.....	300			
27.4.3	Fuel .....	300			
27.5	Chassis .....	301			
27.6	Electrical system.....	301			
27.7	Tires.....	302			
27.8	Fork.....	302			
27.9	Shock absorber.....	302			
27.10	Chassis tightening torques .....	302			

## 1.1 Symbols used

The meaning of specific symbols is described below.



Indicates an expected reaction (e.g. of a work step or a function).



Indicates an unexpected reaction (e.g. of a work step or a function).



Indicates a page reference (more information is provided on the specified page).



Indicates information with more details or tips.



Indicates the result of a testing step.



Indicates a voltage measurement.



Indicates a current measurement.



Indicates a resistance measurement.

## 1.2 Formats used

The typographical formats used in this document are explained below.

<b>Proprietary name</b>	Indicates a proprietary name.
<b>Name<sup>®</sup></b>	Indicates a protected name.
<b>Brand<sup>™</sup></b>	Indicates a brand available on the open market.
<b><u>Underlined terms</u></b>	Refer to technical details of the vehicle or indicate technical terms, which are explained in the glossary.



## 2.1 Repair Manual

Read this Repair Manual carefully and thoroughly before beginning work. It contains useful information and tips that will help you repair and maintain your vehicle.

This manual assumes that the necessary special KTM tools and KTM workplace and workshop equipment are available.

## 2.2 Safety advice

A number of safety instructions need to be followed to operate the vehicle safely. Therefore, read this manual carefully. The safety instructions are highlighted in the text and are referred to at the relevant passages.



### Info

The vehicle has various information and warning labels at prominent locations. Do not remove information/warning labels. If they are missing, you or others may not recognize dangers and may therefore be injured.

## 2.3 Degrees of risk and symbols



### Danger

Indicates a danger that will immediately and invariably lead to fatal or serious permanent injury if the appropriate measures are not taken.



### Warning

Indicates a danger that is likely to lead to fatal or serious injury if the appropriate measures are not taken.



### Caution

Indicates a danger that may lead to minor injuries if the appropriate measures are not taken.

### Note

Indicates a danger that will lead to considerable machine and material damage if the appropriate measures are not taken.



### Warning

Indicates a danger that will lead to environmental damage if the appropriate measures are not taken.

## 2.4 Work rules

Special tools are necessary for some of the work. These are not included with the vehicle and can be ordered under the number in parentheses. Ex: valve spring mounter (59029019000)

During assembly, non-reusable parts (e.g. self-locking screws and nuts, seals and seal rings, O-rings, pins, lock washers) must be replaced by new parts.

Where thread lockers are used on screw connections (e.g., **Loctite**®), follow the instructions for use from the manufacturer.

Parts that you want to reuse following repairs and servicing should be cleaned and checked for damage and wear. Change damaged or worn parts.

Following repairs or servicing, the vehicle must be checked for roadworthiness.

## 3.1 Warranty

The work specified in the service schedule may only be performed in an authorized KTM workshop and must be recorded in both the Service & Warranty Booklet and in **KTM Dealer.net**, otherwise any warranty coverage will become void. No warranty claims can be considered for damage resulting from manipulations and/or alterations to the vehicle.

Additional information on the manufacturer or implied warranty and the procedures involved can be found in the service & warranty booklet.

## 3.2 Operating and auxiliary substances



### Warning

**Environmental hazard** Improper handling of fuel is a danger to the environment.

- Do not allow fuel to enter the groundwater, the soil, or the sewage system.

Use the operating and auxiliary substances (such as fuel and lubricants) as specified in the manual.

## 3.3 Spare parts, accessories

Only use spare parts and accessories approved and/or recommended by KTM. KTM accepts no liability for other products and any resulting damage or loss.

The current **KTM PowerParts** for your vehicle can be found on the KTM website.

International KTM Website: <http://www.ktm.com>

## 3.4 Figures

The figures contained in the manual may depict special equipment.

In the interest of clarity, some components may be shown disassembled or may not be shown at all. It is not always necessary to disassemble the component to perform the activity in question. Please follow the instructions in the text.

## 4.1 Chassis number

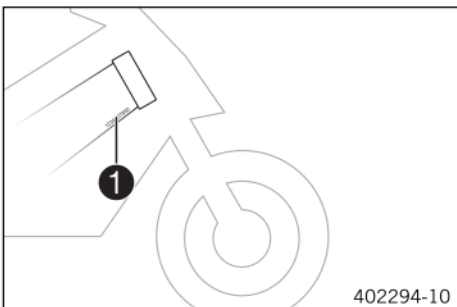

The chassis number ❶ is stamped on the bottom right of the frame behind the steering head.  
The chassis number is also shown on the type label.

## 4.2 Type label

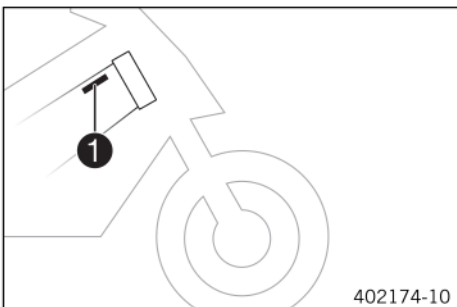

**(Super Adventure EU/FR/AU/JP/CN)**

The type label ❶ is on the top right of the frame behind the steering head.

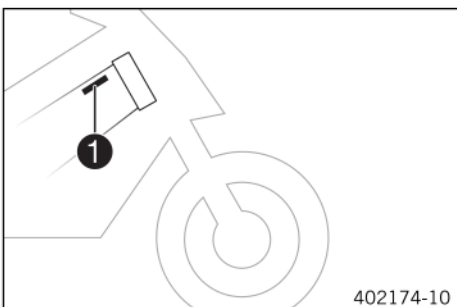

**(Super Adventure US)**

Type label USA ❶ is affixed to the frame behind the steering head at the top right.

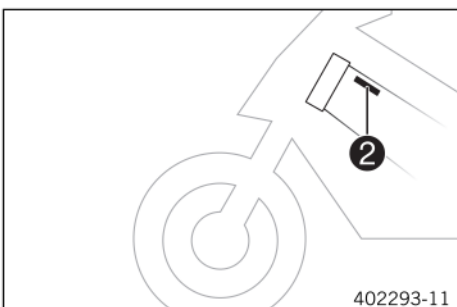

**(Super Adventure US)**

Type label Canada ❷ is affixed to the frame behind the steering head at the top left.

## 4.3 Key number

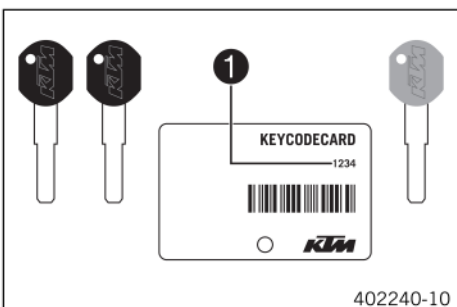

The key number **Code number** ❶ can be found on the **KEYCODECARD**.

### **i** Info

You need the key number to order a spare key. Keep the **KEYCODECARD** in a safe place.

Use the orange programming key to activate and deactivate the black ignition key. Keep the orange programming key in a safe place: it must only be used for learning and programming functions.

## 4.4 Engine number

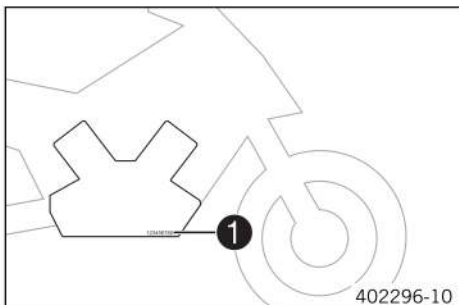

The engine number ❶ is stamped on the right side of the engine.

## 4.5 Fork part number

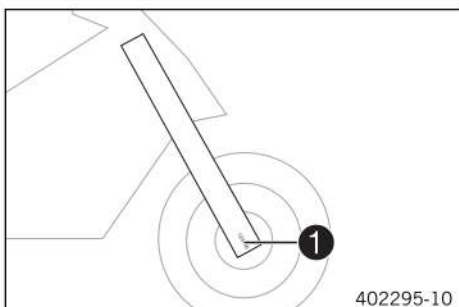

The fork part number ❶ is stamped on the inner side of the fork stub.

## 4.6 Shock absorber article number

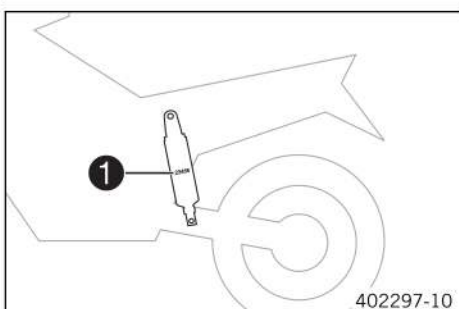

The shock absorber article number ❶ is marked on a sticker on the shock absorber case under the spring.

## 4.7 Steering damper item number

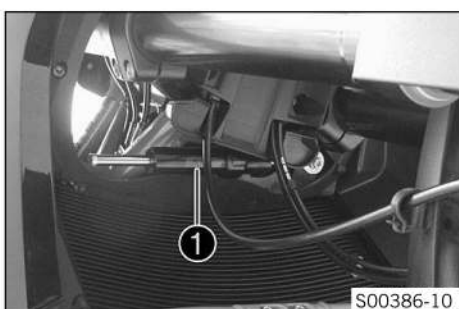

Steering damper item number ❶ is embossed on the underside of the steering damper.

## 5.1 Lifting the motorcycle with the front lifting gear

### Note

**Danger of damage** The parked vehicle can roll away or fall over.

- Park the vehicle on a firm and level surface.



### Preparatory work

- Raise the motorcycle with the rear lifting gear. (📖 p. 11)
- Remove the bottom triple clamp cover. (📖 p. 93)

### Main work

- Move the handlebar to the straight-ahead position.
- Attach the front lifting gear with the adapters on the steering stem.

Mounting pin (69329965030) (📖 p. 353)
---------------------------------------

Lifting gear, front (69329965000) (📖 p. 352)
--

- Align the front lifting gear with the fork legs.



### Info

Always raise the motorcycle at the rear first.

- Raise the motorcycle at the front.

## 5.2 Taking the motorcycle from the front lifting gear

### Note

**Danger of damage** The parked vehicle can roll away or fall over.

- Park the vehicle on a firm and level surface.



### Main work

- Secure the motorcycle against falling over.
- Remove the front lifting gear.

### Finishing work

- Install the bottom triple clamp cover. (📖 p. 93)

## 5.3 Raising the motorcycle with the rear lifting gear

### Note

**Danger of damage** The parked vehicle can roll away or fall over.

- Park the vehicle on a firm and level surface.

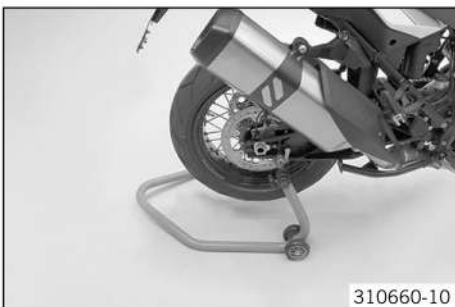

- Mount lifting bushings on the swingarm.
- Insert the adapter in the rear lifting gear.

Retaining adapter (61029955144) (📖 p. 348)
--

Lifting gear, rear (69329955000) (📖 p. 352)
---

- Place the motorcycle vertically, use the adapters to direct the lifting gear towards the swingarm and lift the motorcycle.

## 5.4 Removing the rear of motorcycle from the lifting gear

### Note

**Danger of damage** The parked vehicle can roll away or fall over.

- Park the vehicle on a firm and level surface.

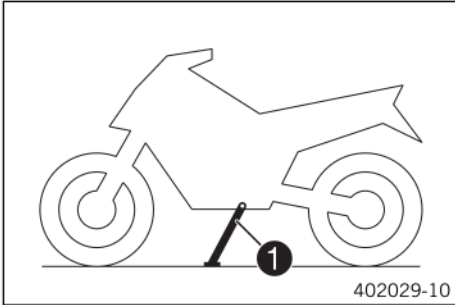

- Secure the motorcycle against falling over.
- Remove the rear lifting gear and lean the motorcycle on the side stand ❶.
- Remove the lifting bushings from the swingarm.

## 5.5 Raising the vehicle with the center stand

### Note

**Danger of damage** The parked vehicle can roll away or fall over.

- Park the vehicle on a firm and level surface.

### Note

**Material damage** Damage and destruction of components from excessive load.

- The center stand is only designed for the weight of the motorcycle and the baggage. Do not sit on the motorcycle when it is resting on the center stand. The center stand or the frame may become damaged and the motorcycle may fall over.
- Pull the motorcycle up onto the center stand at the grab handles.

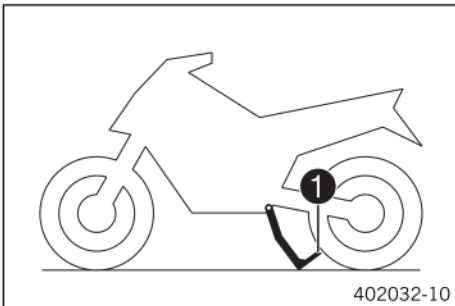

- Stand to the left of the vehicle.
- Hold the handlebar with your left hand and push the center stand onto the ground with your right foot.
- Put your entire weight on arm ❶ of the center stand while pulling the vehicle up at the left grab handle.
- ✓ The center stand is folded out to the stop.

## 5.6 Removing the vehicle from the center stand

### Note

**Danger of damage** The parked vehicle can roll away or fall over.

- Park the vehicle on a firm and level surface.

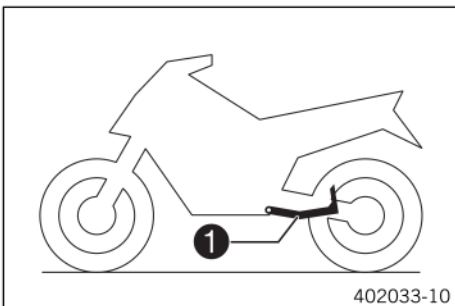

- Make sure that the steering is unlocked.
- Move the vehicle forward with both hands on the handlebar.
- While the vehicle tips off of the center stand, activate the front brake to stop the vehicle from rolling away.
- Check that the center stand ❶ is folded all the way up.

## 5.7 Starting

**Danger**  
**Danger of poisoning** Exhaust gases are toxic and inhaling them may result in unconsciousness and death.

- Always make sure there is sufficient ventilation when running the engine.
- Use an effective exhaust extraction system when starting or running the engine in an enclosed space.



**Caution**  
**Danger of accidents** Electronic components and safety devices will be damaged if the battery is discharged or missing.

- Never operate the vehicle with a discharged battery or without a battery.

**Note**  
**Engine damage** High revving speed with a cold engine negatively impacts the lifespan of the engine.

- Always run the engine warm at a low speed.



- Press the emergency OFF switch to the position **ON** .
- Switch on the ignition by turning the black ignition key to the position **ON** .
  - ✓ After you switch on the ignition, you can hear the fuel pump working for about two seconds. The function check of the combination instrument is run at the same time.
  - ✓ The **ABS** lamp lights up and goes back out after starting off.
- Shift the transmission to idle **N**.
  - ✓ The green idling speed indicator lamp **N** lights up.



- Press the electric starter button .

**i Info**  
 Do not press the electric starter button until the combination instrument function check is finished.  
 When starting, **DO NOT** open the throttle. If you open the throttle during the starting procedure, fuel is not injected by the engine management system and the engine cannot start.  
 Press the electric starter button  for at most 5 seconds. Wait for a least 5 seconds before trying again.  
 This motorcycle is equipped with a safety starting system. You can only start the engine if the transmission is in neutral or if the clutch lever is pulled when a gear is engaged. If the side stand is folded out and you shift into gear, the engine stops.

- Remove the motorcycle from the center stand or side stand.



## 5.8 Starting the motorcycle to check the function

**Danger**  
**Danger of poisoning** Exhaust gases are toxic and inhaling them may result in unconsciousness and death.

- Always make sure there is sufficient ventilation when running the engine.
- Use an effective exhaust extraction system when starting or running the engine in an enclosed space.

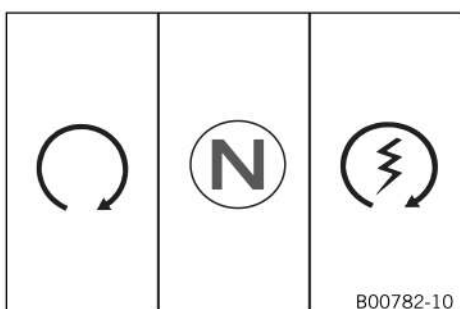
**i Info**  
 Press the starter for a maximum of 5 seconds. Wait for a least 5 seconds before trying again.



- Press the emergency OFF switch to the position **ON** .
- Switch on the ignition by turning the black ignition key to the position **ON** .
- Shift the transmission to idle **N**.
- Press the electric starter button .

**i Info**  
 Do not open the throttle.

## 6.1 Cleaning the dust boots of the fork legs



### Preparatory work

- Raise the vehicle with the center stand. (📖 p. 12)
- Remove the front fender. (📖 p. 94)

### Main work

- Push dust boots ❶ of both fork legs downward.



### Info

The dust boots should remove dust and coarse dirt particles from the fork tubes. Over time, dirt can accumulate behind the dust boots. If this dirt is not removed, the oil seals behind can start to leak.



### Warning

**Danger of accidents** Oil or grease on the brake discs reduces the braking effect.

- Always keep the brake discs free of oil and grease.
- Clean the brake discs with brake cleaner when necessary.

- Clean and oil the dust boots and inner fork tubes of both fork legs.

Universal oil spray (📖 p. 341)

- Press dust boots ❶ back into their installation position.
- Remove excess oil.

### Finishing work

- Install the front fender. (📖 p. 94)
- Remove the vehicle from the center stand. (📖 p. 12)

## 6.2 Removing the fork legs

### Preparatory work

- Raise the vehicle with the center stand. (📖 p. 12)
- Clamp down the rear of the vehicle.
- Remove the front fender. (📖 p. 94)
- Remove the front wheel. (📖 p. 99)
- Remove the bottom triple clamp cover. (📖 p. 93)

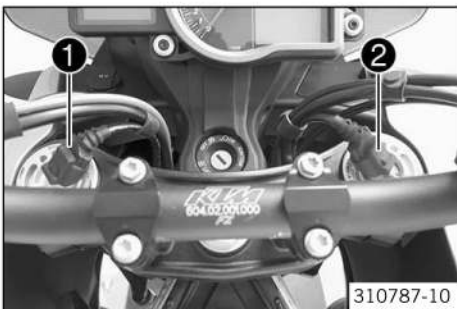

### Main work

- Detach connectors ❶ and ❷.



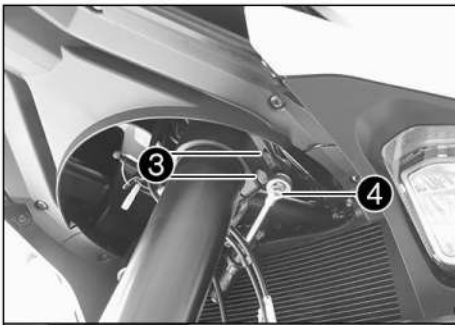

- Loosen screws ③ of the lower triple clamp.
- Remove screw ④ of the steering damper.
- Loosen screw ⑤ of the steering damper clamp.

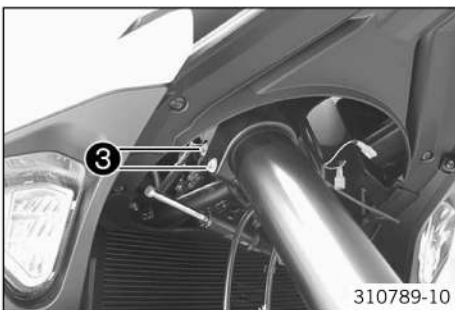
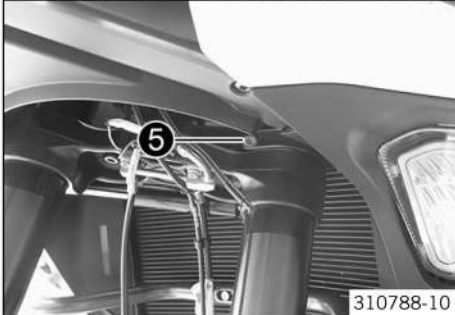

- Loosen screws ③ of the lower triple clamp.

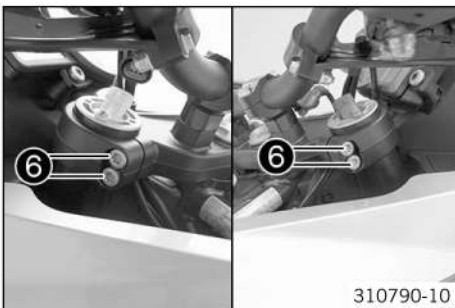

- Loosen screws ⑥ of the upper triple clamp.
- Remove the fork legs from the bottom.

## 6.3 Installing the fork legs



### Warning

**Danger of accidents** Modifications to the suspension settings can seriously alter the vehicle's ride behavior.

- Following modifications, ride slowly at first to get the feel of the new ride behavior.

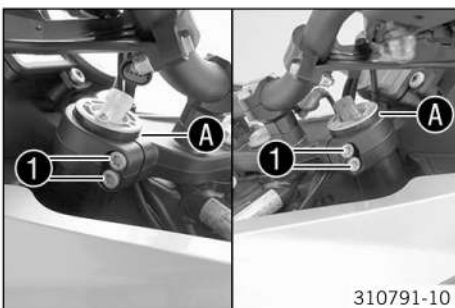

### Main work

- Slide the left-hand fork leg into the triple clamps and the steering damper clamp.
  - ✓ The left-hand fork leg has a white connector; the right-hand fork leg has a red connector.
  - ✓ The connector faces forward at an angle toward the center of the vehicle.
- Push the right fork leg into the triple clamps.
  - ✓ The left-hand fork leg has a white connector; the right-hand fork leg has a red connector.
  - ✓ The connector faces forward at an angle toward the center of the vehicle.
- Align the fork legs in the specified position by means of fork rings A.

### Guideline

Upper triple clamp flush with 2nd ring of fork legs.

- Tighten screws **1** of the upper triple clamp.

Guideline

Screw, top triple clamp	M8	20 Nm (14.8 lbf ft)
-------------------------	----	------------------------

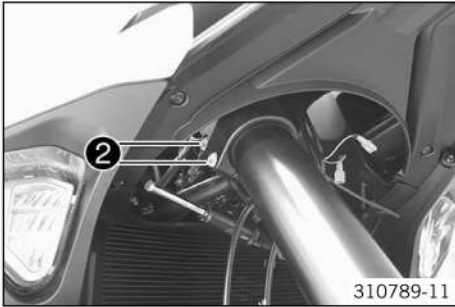

- Tighten screws **2** of the lower triple clamp.

Guideline

Screw, bottom triple clamp	M8	12 Nm (8.9 lbf ft)
----------------------------	----	--------------------

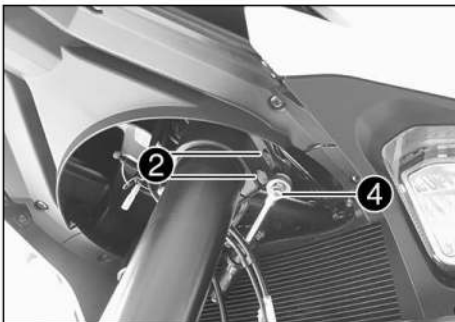

- Tighten screws **2** of the lower triple clamp.

Guideline

Screw, bottom triple clamp	M8	12 Nm (8.9 lbf ft)
----------------------------	----	--------------------

- Align the steering damper clamp to the lower triple clamp.

Guideline

The clamp is aligned with the contour of the lower triple clamp and lies on top of the lower triple clamp.

- Tighten screw **3**.

Guideline

Screw, steering damper clamp	M8	12 Nm (8.9 lbf ft)
------------------------------	----	--------------------

- Position the steering damper.

- Mount and tighten screw **4**.

Guideline

Screw, steering damper	M8	25 Nm (18.4 lbf ft)	<b>Loctite® 243™</b>
------------------------	----	------------------------	----------------------

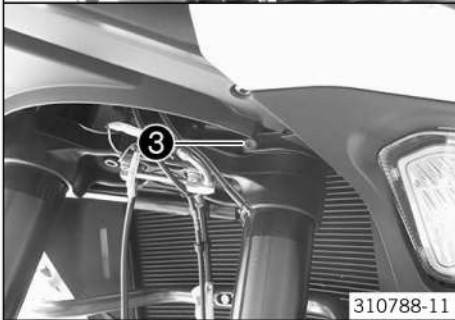

- Plug in connectors **5** and **6**.

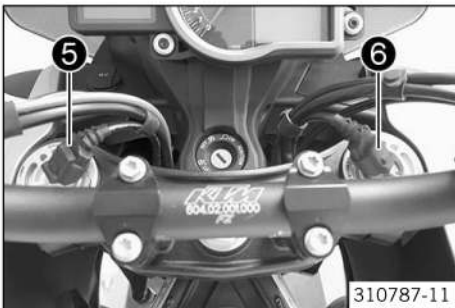

**Finishing work**

- Install the bottom triple clamp cover. (📖 p. 93)
- Install the front wheel. (📖 p. 100)
- Install the front fender. (📖 p. 94)

**6.4 Performing a fork service**

**Condition**

The fork legs have been removed.

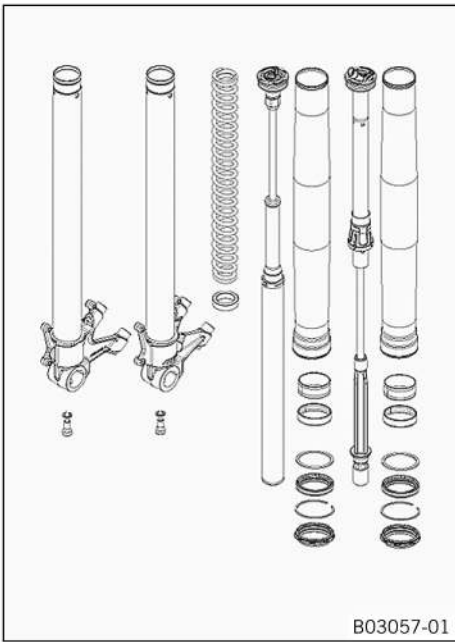

- Disassemble the fork legs. (📖 p. 17)
- Remove the spring. (📖 p. 19)
- Check the fork legs. (📖 p. 20)
- Install the spring. (📖 p. 19)
- Assemble the fork legs. (📖 p. 21)

## 6.5 Disassembling the fork legs

**i Info**  
These operations are the same on both fork legs.

**Condition**  
The fork legs have been removed.

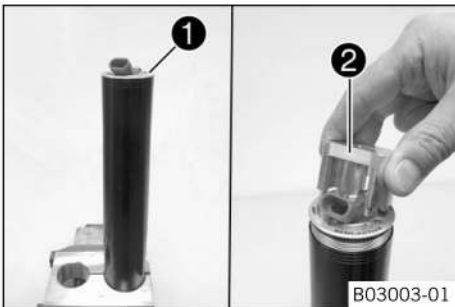

- Clamp the fork leg in the area of the lower triple clamp.  
Clamping stand (T1403S) (📖 p. 357)
- Release screw cover **1** with special tool **2**.  
Special socket (T14071) (📖 p. 357)

**i Info**  
The screw cover cannot be removed.



- Unclamp the fork.
- Drain the fork oil.

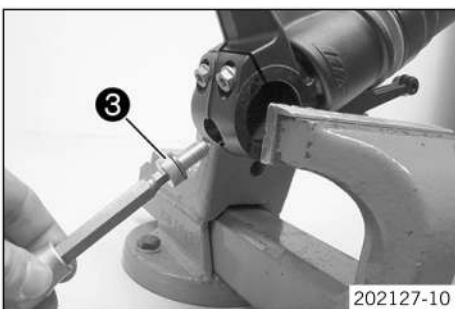

- Remove cartridge screw **3** with the washer.



- Remove the cartridge.

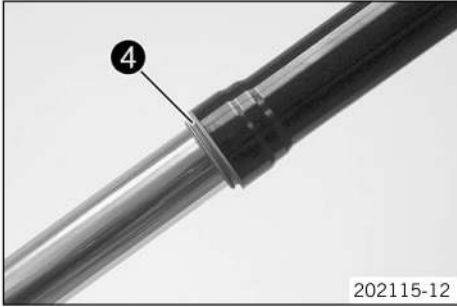

- Remove dust boot ④.

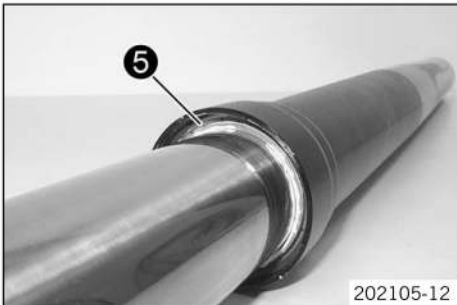

- Remove lock ring ⑤.



**Info**

The lock ring has a beveled end where a screwdriver can be applied.

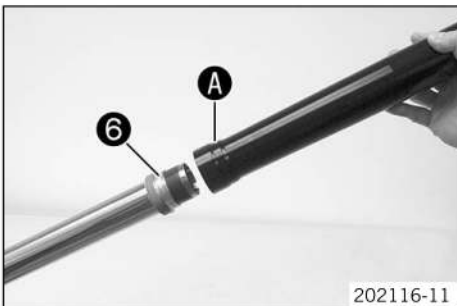

- Heat up the outer tube in area A of the lower sliding bushings.

Guideline

50 °C (122 °F)

- Pull the outer tube from the inner tube with a jerk.



**Info**

The lower sliding bushing ⑥ must be pulled from its bearing seat.

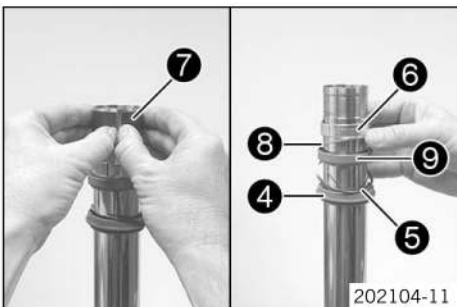

- Remove the upper sliding bushing ⑦.



**Info**

Without using a tool, carefully pull the stack apart by hand.

- Take off the lower sliding bushing ⑥.
- Take off support ring ⑧.
- Take off seal ring ⑨.
- Take off lock ring ⑤.
- Take off dust boot ④.
- Unclamp the fork leg.

## 6.6 Removing the spring

**i Info**  
These operations only apply to the left fork leg.

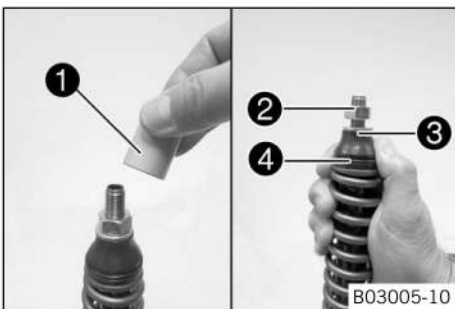
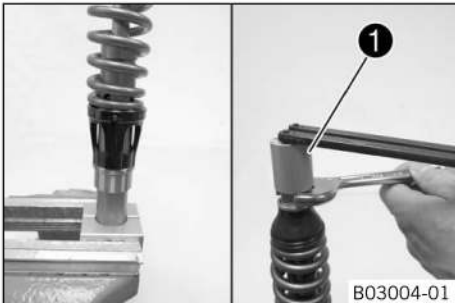

### Preparatory work

- Disassemble the fork legs. (📖 p. 17)

### Main work

- Clamp the cartridge into a vise.

Clamping stand (T14015S) (📖 p. 356)

- Hold nut securely and loosen threaded bushing ① with special tool.

Pin wrench (T103) (📖 p. 356)

- Remove threaded bushing ①.
- Pull the spring down and remove nut ② with the washer.
- Remove spring guide ③ with preload spacer ④.
- Remove the spring. Unclamp the cartridge.

## 6.7 Installing the spring

**i Info**  
These work steps only apply to the left fork leg.

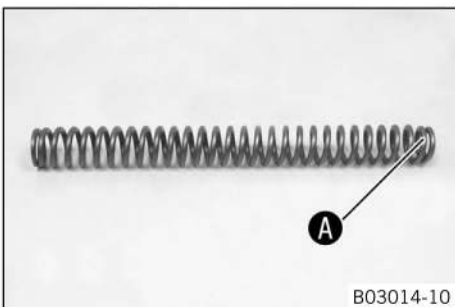

- Observe the installation position of the springs.  
✓ Tight coil A points toward the spring guide.

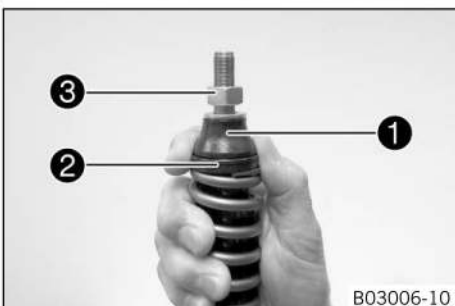

- Clamp the cartridge into a vise.
- Clamping stand (T14015S) (📖 p. 356)
- Position the spring.
  - Position spring guide ① with preload spacer ②.
  - Pull the spring down and mount nut ③ with the washer. Screw the nut all the way down.

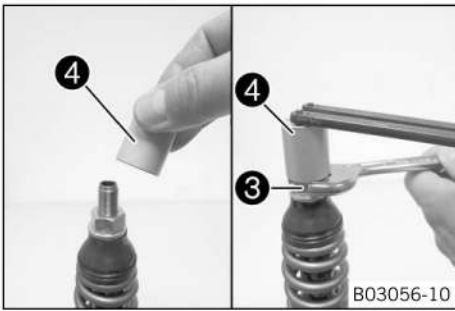

- Screw on threaded bushing ④ all the way.
- Hold threaded bushing ④ and tighten nut ③.

## 6.8 Checking the fork legs

### Condition

Fork disassembled.

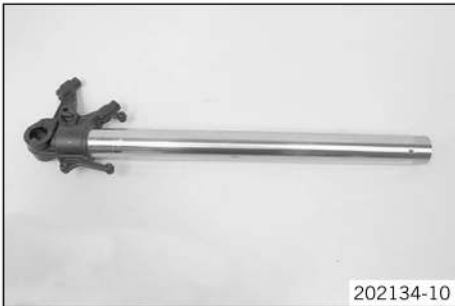

- Check the inner tube and axle clamp for damage.
  - » If there is damage:
    - Change the inner tube.

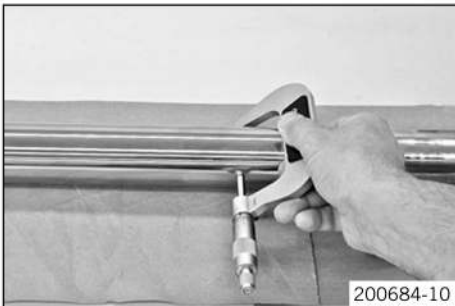

- Measure the outside diameter at several locations on the inner tube.

Outside diameter of inner tube	47.975... 48.005 mm (1.88878... 1.88996 in)
--------------------------------	---

- » If the measured value is less than the specified value:
  - Change the inner tube.

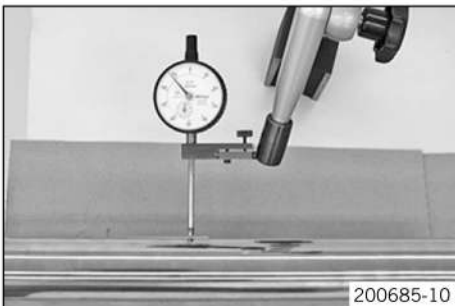

- Measure the run-out of the inner tube.

Run-out of inner tube	≤ 0.20 mm (≤ 0.0079 in)
-----------------------	-------------------------

- » If the measured value is greater than the specified value:
  - Change the inner tube.



- Check the outer tube for damage.
  - » If there is damage:
    - Change the outer tube.

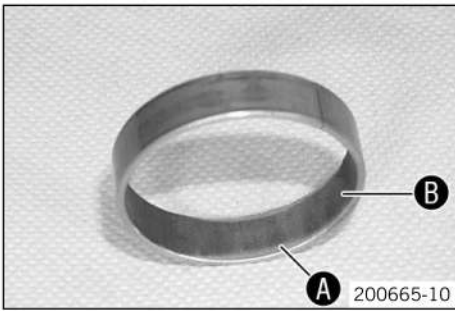

- Check the surface of the sliding bushings.
  - » If the bronze-colored layer **A** under the sliding layer **B** is visible:
    - Replace the sliding bushings.



- Check the spring length.

Guideline

Spring length with preload spacer(s)	440 mm (17.32 in)
--------------------------------------	-------------------

- » If the measured value is greater than the specified value:
  - Reduce the thickness of the preload spacers.
- » If the measured value is less than the specified value:
  - Increase the thickness of the preload spacers.

## 6.9 Assembling the fork legs



### Info

The procedures are the same on both fork legs.

### Preparatory work

- Check the fork legs. (📖 p. 20)
- Install the spring. (📖 p. 19)

### Main work

- Clamp the inner tube with the axle clamp.

Guideline

Use soft jaws.
----------------

- Mount the special tool.

Protecting sleeve (T1401) (📖 p. 356)
--------------------------------------

- Grease and push on dust boot **1**.

Lubricant (T14034) (📖 p. 340)
-------------------------------

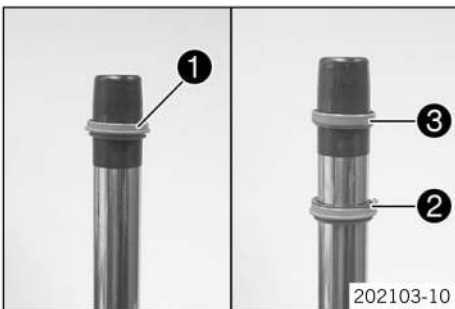

### Info

Always change the dust boot, seal ring, lock ring, and support ring. Mount the sealing lip with the spring expander facing down.

- Push on lock ring **2**.
- Grease and push on seal ring **3**.

Lubricant (T14034) (📖 p. 340)
-------------------------------

✓ The sealing lip points downward, the open side upward.

- Remove the special tool.

- Push on support ring **4**.

- Sand the edges of the sliding bushings with 600 grit sandpaper; then clean and grease the bushings.

Fork oil (SAE 4) (48601166S1) (📖 p. 339)
--

- Push on lower sliding bushing **5**.
- Mount upper sliding bushing **6**.

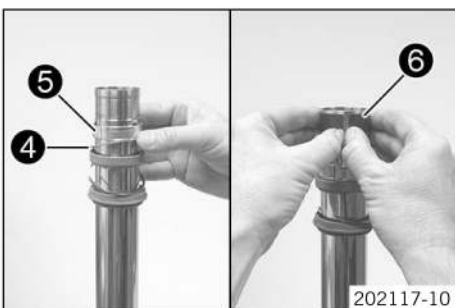

### Info

Without using a tool, pull the stack slightly apart by hand.

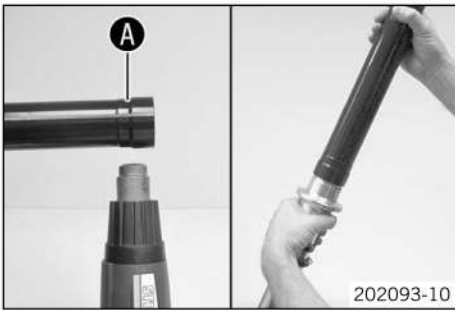

- Heat up outer tube in area **A** of the lower sliding bushings.

Guideline

50 °C (122 °F)

- Hold the lower sliding bushing with the longer side of the special tool.

Mounting tool (T14040S) (📄 p. 357)

- Push on the outer tube.
- Press the sliding bushing all the way into the outer tube.



- Position the support ring.
- Hold the seal ring with the shorter side of the special tool.

Mounting tool (T14040S) (📄 p. 357)

- Press the seal ring and support ring all the way into the outer tube.

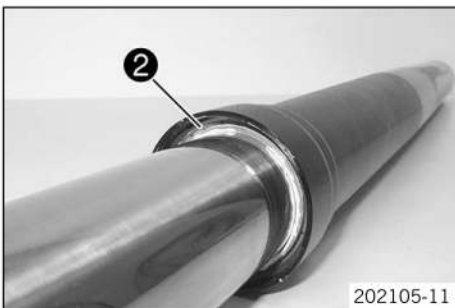

- Mount lock ring **2**.

**i** Info

The lock ring must engage audibly.

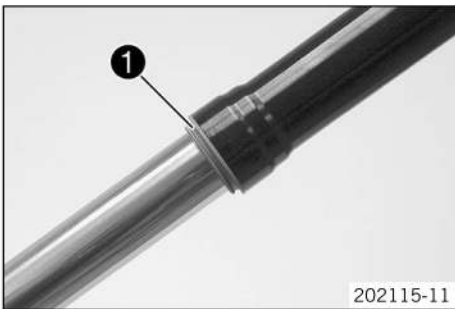

- Mount dust boot **1**.

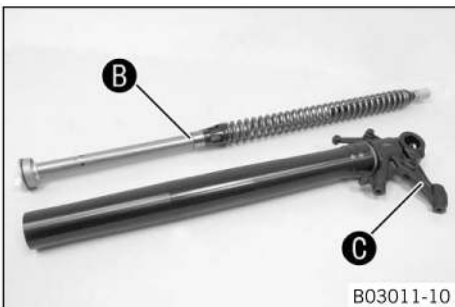

- Assemble the individual components that belong together.

**i** Info

Sensor side (left fork leg): cartridge with spring and white plug **B**, axle clamp with label **L** **C**.

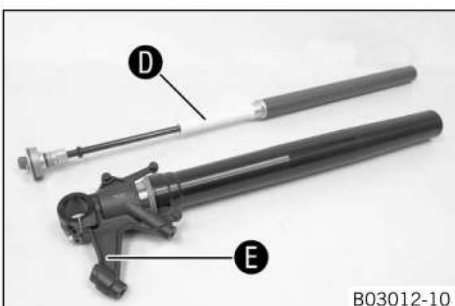

- Assemble the individual components that belong together.

**i** Info

Actuator side (right fork leg): cartridge without spring, red plug **D**, axle clamp with label **R** **E**.





- Slide the cartridge into the inner tube.

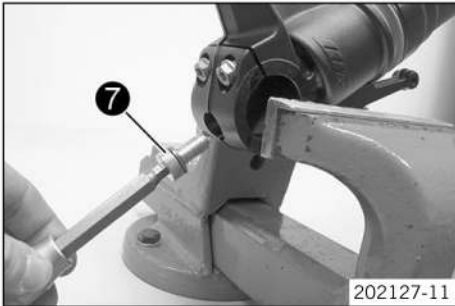

- Mount and tighten cartridge screw **7** with the washer.

Guideline

Screw, cartridge	M12x1	25 Nm (18.4 lbf ft)
------------------	-------	------------------------



- Clamp right fork leg vertically.

Guideline

Use soft jaws.
----------------

- Fill with fork oil.

Fork oil per fork leg	430 ml (14.54 fl. oz.)	Fork oil (SAE 4) (48601166S1) ( p. 339)
-----------------------	---------------------------	--



- Clamp left fork leg vertically.

Guideline

Use soft jaws.
----------------

- Fill with fork oil.

Fork oil per fork leg	680 ml (22.99 fl. oz.)	Fork oil (SAE 4) (48601166S1) ( p. 339)
-----------------------	---------------------------	--



- Push the outer tube upward.

**Info**

The following work steps apply to both fork legs.

- Clamp the outer tube in the area of the lower triple clamp.

Clamping stand (T1403S) ( p. 357)
-----------------------------------

- Grease the O-ring of the screw cover.

Lubricant (T158) ( p. 340)
----------------------------

- Screw on and tighten screw cap **8**.

Guideline

Screw cover on outer tube	M47x1.5	40 Nm (29.5 lbf ft)
---------------------------	---------	------------------------

Special socket (T14071) ( p. 357)
-----------------------------------

## 6.10 Checking the steering head bearing play

- Warning**  
**Danger of accidents** Incorrect steering head bearing play impairs the handling characteristic and damages components.
- Correct incorrect steering head bearing play immediately.

**i Info**  
 If the vehicle is operated for a lengthy period with play in the steering head bearing, the bearings and the bearing seats in the frame can become damaged over time.

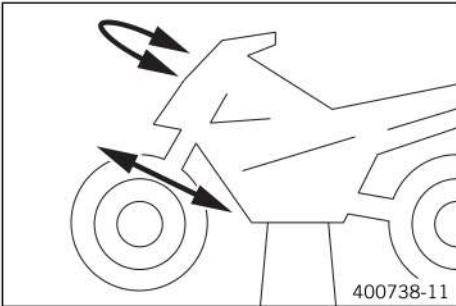

### Preparatory work

- Raise the vehicle with the center stand. (📖 p. 12)

### Main work

- Place a load on the rear of the vehicle.
  - ✓ The front wheel is not in contact with the ground.
- Move the handlebar to the straight-ahead position. Move the fork legs back and forth in the direction of travel.

Play should not be detectable on the steering head bearing.

- » If there is no detectable play:
  - Adjust the steering head bearing play. (📖 p. 24)
- Move the handlebar to and fro over the entire steering range.

It must be possible to move the handlebar easily over the entire steering range. There should be no detectable detent positions.

- » If detent positions are detected:
  - Adjust the steering head bearing play. (📖 p. 24)
  - Check the steering head bearing and adjust if necessary.

### Finishing work

- Remove the vehicle from the center stand. (📖 p. 12)

## 6.11 Adjusting the steering head bearing play

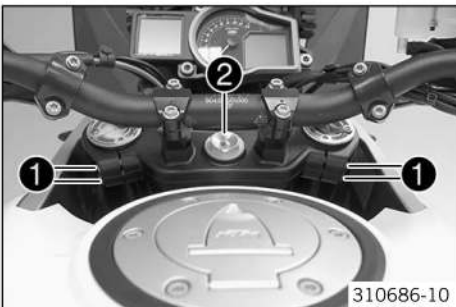

### Preparatory work

- Raise the vehicle with the center stand. (📖 p. 12)

### Main work

- Loosen screws 1 and 2.



- Loosen and retighten nut 3.

### Guideline

Nut, steering head, top	M28x1.0	Step 1 10 Nm (7.4 lbf ft) Step 2 (loosen, counterclockwise) 60°
-------------------------	---------	--

Torque wrench with various accessories in set (58429094000) (📖 p. 345)

Mount for torque wrench (58429094100) (📖 p. 345)

- Using a plastic hammer, tap lightly on the upper triple clamp to avoid strains.

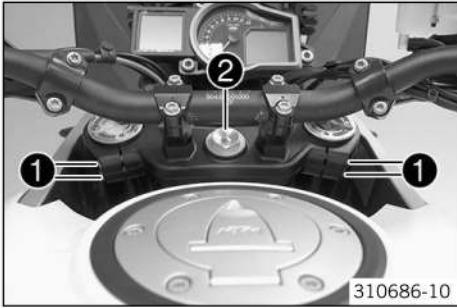

- Tighten screw ②.

Guideline

Screw, steering head, top	M22x1.5	46.5 Nm (34.3 lbf ft)	Only applies when using: Holding wrench for steering head bearing (45229050000) (p. 343)
---------------------------	---------	--------------------------	---

- Tighten screws ①.

Guideline

Screw, top triple clamp	M8	20 Nm (14.8 lbf ft)	
-------------------------	----	------------------------	--

**Finishing work**

- Check the steering head bearing play. (p. 24)
- Remove the vehicle from the center stand. (p. 12)

## 6.12 Lubricating the steering head bearing

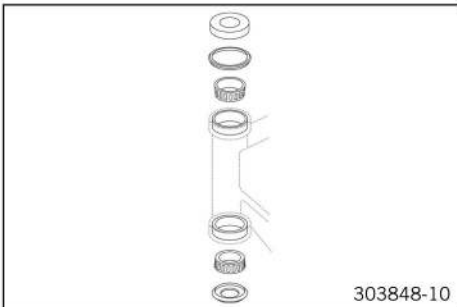

- Remove the lower triple clamp. (p. 25)
- Install the lower triple clamp. (p. 26)

## 6.13 Removing the lower triple clamp

**Preparatory work**

- Raise the vehicle with the center stand. (p. 12)
- Clamp down the rear of the vehicle.
- Remove the front fender. (p. 94)
- Remove the front wheel. (p. 99)
- Remove the bottom triple clamp cover. (p. 93)
- Remove the fork legs. (p. 14)

**Main work**

- Remove screws ①. Take off the brake line and hang it to the side.

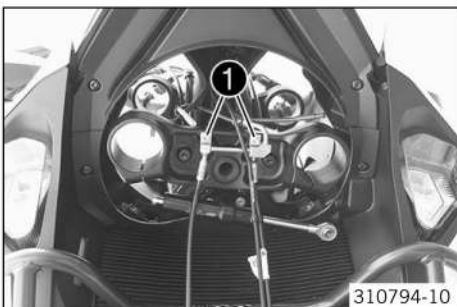



- Remove screws 2 with the handlebar clamps.
- Remove the handlebar and lay it to one side.



**Info**  
Cover the components to protect them against damage.  
Do not bend the cables and lines.



- Remove screw 3.
- Remove upper triple clamp.

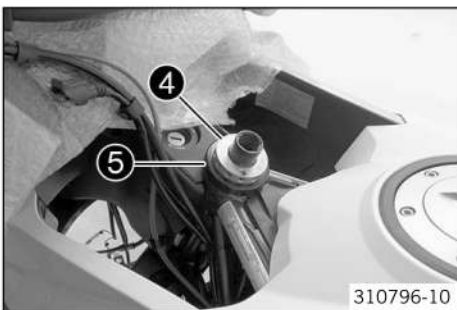

- Remove nut 4. Remove protective ring 5.



**Info**  
Hold the lower triple clamp.

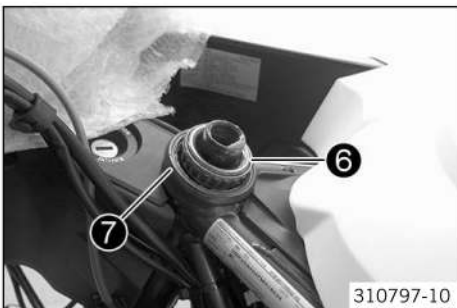

- Take out the lower triple clamp with the steering stem.
- Take out upper steering head bearing 6.
- Remove steering head seal 7.

## 6.14 Installing the lower triple clamp

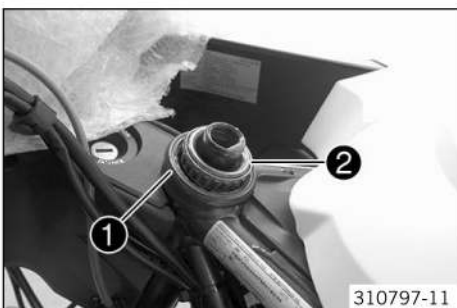

### Main work

- Grease the bearing, clean the sealing elements, and check for damage.

High viscosity grease (📖 p. 340)

- Mount steering head seal 1.
- Insert the lower triple clamp with the steering stem. Mount upper steering head bearing 2.

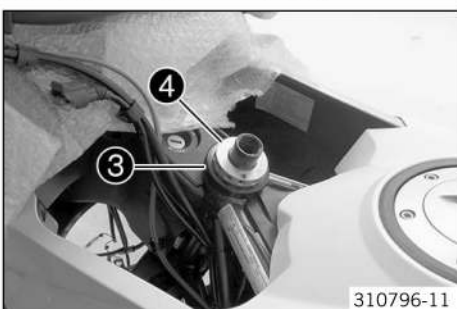

- Position protective ring 3.
- Mount and tighten nut 4.

### Guideline

Nut, steering head, top	M28x1.0	Step 1 10 Nm (7.4 lbf ft) Step 2 (loosen, counterclockwise) 60°
-------------------------	---------	---

Torque wrench with various accessories in set (58429094000) (📖 p. 345)

Mount for torque wrench (58429094100) (📖 p. 345)

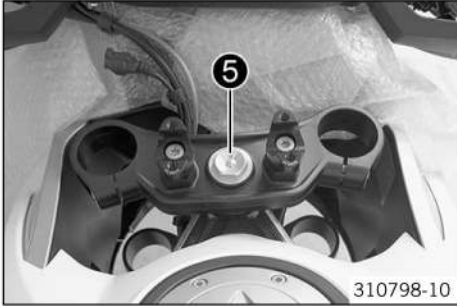

- Position the upper triple clamp.
- Mount screw **5** but do not tighten yet.

Guideline

Screw, steering head, top	M22x1.5	50 Nm (36.9 lbf ft)
---------------------------	---------	------------------------

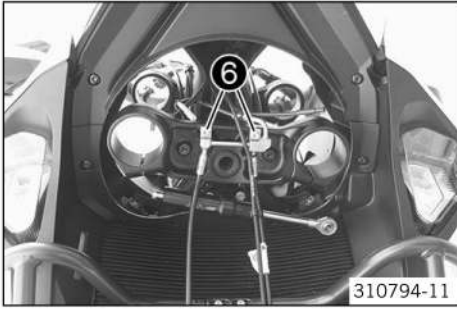

- Position the brake lines. Mount and tighten screws **6**.

Guideline

Remaining chassis screws	M6	10 Nm (7.4 lbf ft)
--------------------------	----	--------------------

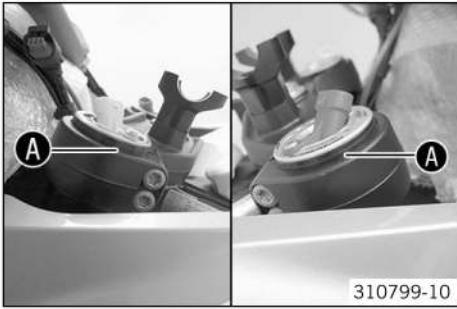

- Slide the left-hand fork leg into the triple clamps and the steering damper clamp.
  - ✓ The left-hand fork leg has a white connector; the right-hand fork leg has a red connector.
  - ✓ The connector faces forward at an angle toward the center of the vehicle.
- Push the right fork leg into the triple clamps.
  - ✓ The left-hand fork leg has a white connector; the right-hand fork leg has a red connector.
  - ✓ The connector faces forward at an angle toward the center of the vehicle.
- Align the fork legs in the specified position by means of fork rings **A**.

Guideline

Upper triple clamp flush with 2nd ring of fork legs.

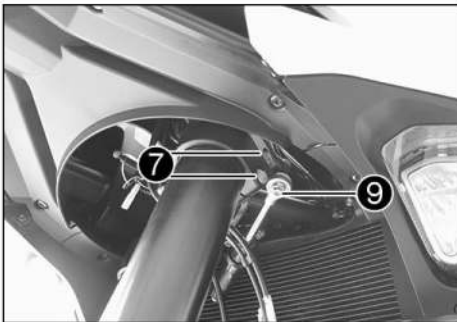

- Tighten screws **7** of the lower triple clamp.

Guideline

Screw, bottom triple clamp	M8	12 Nm (8.9 lbf ft)
----------------------------	----	--------------------

- Align the steering damper clamp to the lower triple clamp.

Guideline

The clamp is aligned with the contour of the lower triple clamp and lies on top of the lower triple clamp.

- Tighten screw **8**.

Guideline

Screw, steering damper clamp	M8	12 Nm (8.9 lbf ft)
------------------------------	----	--------------------

- Position the steering damper.
- Mount and tighten screw **9**.

Guideline

Screw, steering damper	M8	25 Nm (18.4 lbf ft)	Loctite® 243™
------------------------	----	------------------------	---------------

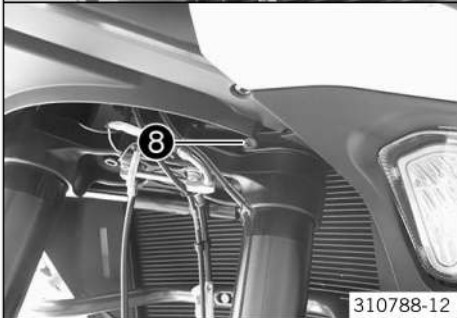

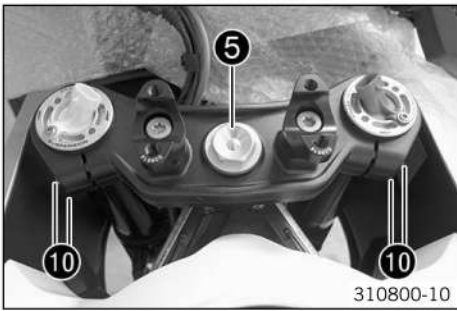

- Tighten screw 5.

Guideline

Screw, steering head, top	M22x1.5	50 Nm (36.9 lbf ft)
---------------------------	---------	------------------------

- Using a plastic hammer, tap lightly on the upper triple clamp to avoid stresses.
- Tighten screws 10 of the upper triple clamp.

Guideline

Screw, top triple clamp	M8	20 Nm (14.8 lbf ft)
-------------------------	----	------------------------

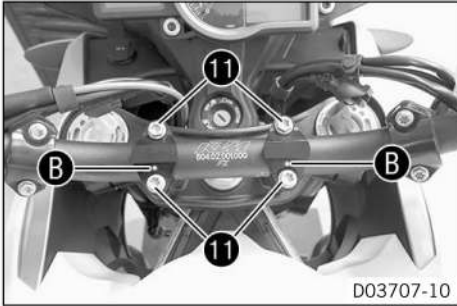

- Position the handlebar.
- Position the handlebar clamps. Mount and tighten screws 11.

Guideline

Screw, handlebar clamp	M8	20 Nm (14.8 lbf ft)
------------------------	----	------------------------

- ✓ The markings B face backwards.

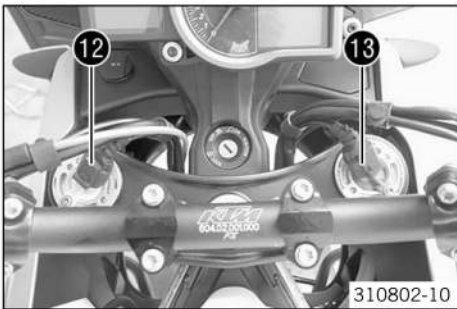

- Plug in connectors 12 and 13.

### Finishing work

- Install the bottom triple clamp cover. (p. 93)
- Install the front wheel. (p. 100)
- Install the front fender. (p. 94)
- Check the steering head bearing play. (p. 24)
- Remove the vehicle from the center stand. (p. 12)

## 6.15 Changing the steering head bearing

### Preparatory work

- Raise the vehicle with the center stand. (p. 12)
- Clamp down the rear of the vehicle.
- Remove the front fender. (p. 94)
- Remove the front wheel. (p. 99)
- Remove the bottom triple clamp cover. (p. 93)
- Remove the fork legs. (p. 14)
- Remove the lower triple clamp. (p. 25)

### Main work

- Remove lower bearing ring 1.

Tool bracket (58429089000) (p. 344)
Press-out tool (58429092000) (p. 345)





- Press in the new bearing ring as far as it will go.

Tool bracket (58429089000) (📖 p. 344)

Press-in tool (58429091000) (📖 p. 345)

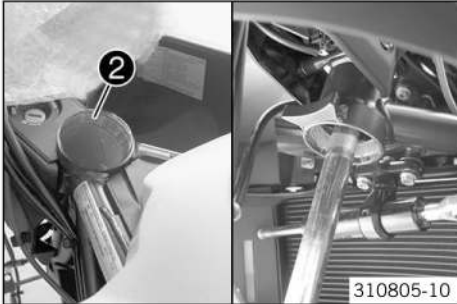

- Remove upper bearing ring ②.

Tool bracket (58429089000) (📖 p. 344)

Press-out tool (58429092000) (📖 p. 345)



- Press in the new bearing ring as far as it will go.

Tool bracket (58429089000) (📖 p. 344)

Press-in tool (58429091000) (📖 p. 345)

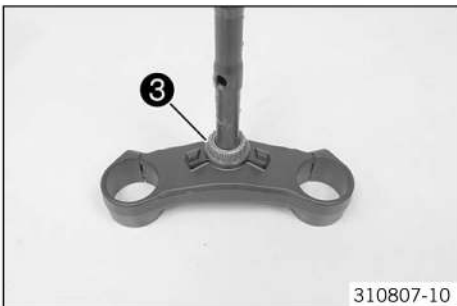

- Remove lower steering head bearing ③.
- Press on the new bearing with a suitable tube as far as it will go.



**Info**

Only press the bearing in via the inner ring.

## 6.16 Changing the steering damper

**Preparatory work**

- Remove the bottom triple clamp cover. (📖 p. 93)

**Main work**

- Remove screw ①.



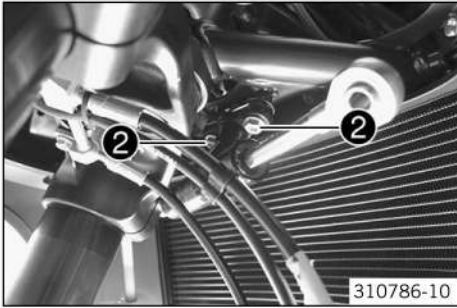

- Remove screws ②.
- Remove the steering damper.
- Position the new steering damper.
- Mount and tighten screws ②.

Guideline

Screw, steering damper	M6	10 Nm (7.4 lbf ft)	Loctite® 243™
------------------------	----	-----------------------	---------------



- Check that the clamp is seated correctly.



**Info**

For purposes of illustration, the following operations are shown with the headlight mask deinstalled.

The clamp is aligned with the contour of the lower triple clamp and lies on top of the lower triple clamp.

- » If the clamp is not aligned with the contour of the lower triple clamp or does not lie on top of the lower triple clamp:
  - Loosen screw ③ and the position clamp.
  - Mount and tighten screw ③.

Guideline

Screw, steering damper clamp	M8	12 Nm (8.9 lbf ft)	
------------------------------	----	-----------------------	--

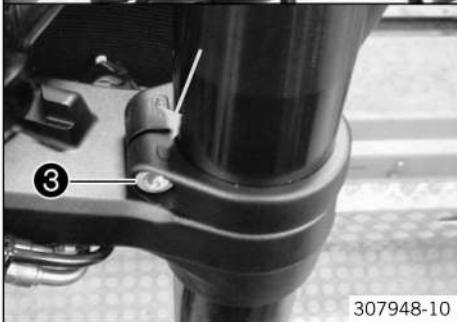

- Mount and tighten screw ①.

Guideline

Screw, steering damper	M8	25 Nm (18.4 lbf ft)	Loctite® 243™
------------------------	----	------------------------	---------------

**Finishing work**

- Install the bottom triple clamp cover. (📖 p. 93)



## 7.1 Adjusting basic position of clutch lever



- Adjust the basic setting of the clutch lever to your hand size by turning adjusting screw ①.

**i** **Info**

Turn the adjusting screw clockwise to increase the distance between the clutch lever and the handlebar.  
Turn the adjusting screw counterclockwise to decrease the distance between the clutch lever and the handlebar.  
The range of adjustment is limited.  
Turn the adjusting screw by hand only, and do not apply any force.  
Do not make any adjustments while riding!

## 7.2 Adjusting the handlebar position

**!** **Warning**

**Danger of accidents** A repaired handlebar poses a safety risk.  
If the handlebar is bent or straightened, the material becomes fatigued. The handlebar may break as a result.

- Change the handlebar if the handlebar is damaged or bent.

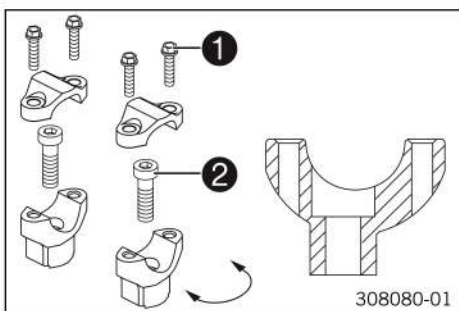

- Remove screws ①. Remove the handlebar clamps. Remove the handlebar and lay it to one side.

**i** **Info**

Cover the components to protect them against damage.  
Do not bend the cables and lines.

- Remove screws ②. Take off the handlebar supports.
- Place the handlebar supports in the required position. Mount and tighten screws ②.

**Guideline**

Screw, handlebar support	M10	40 Nm (29.5 lbf ft)	<b>Loctite® 243™</b>
--------------------------	-----	------------------------	----------------------

**i** **Info**

Position the left and right handlebar supports evenly.

- Position the handlebar.

**i** **Info**

Make sure the cables and wiring are positioned correctly.

- Position the handlebar clamps. Mount and evenly tighten screws ①.

**Guideline**

Screw, handlebar clamp	M8	20 Nm (14.8 lbf ft)
------------------------	----	------------------------

- ✓ The markings **A** of the handlebar scale are located centrally between the handlebar clamps.
- ✓ Markings **B** face backwards.

**i** **Info**

Make sure the gap widths are even.

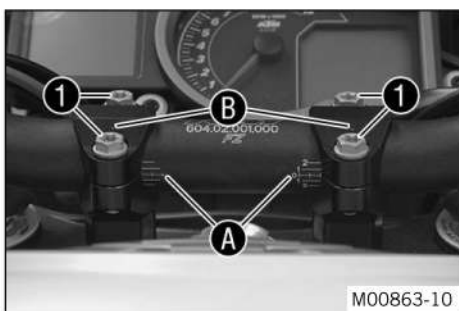

## 7.3 Removing the crash bar



- Remove screw connections ①.

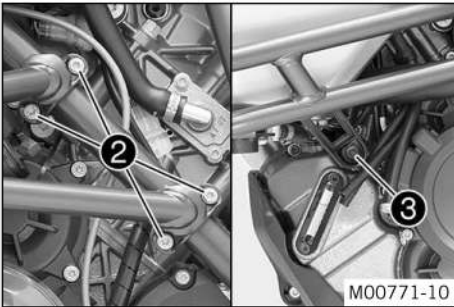

- Remove screws ② and take off the clamp halves.
- Remove screw ③.
- Take off the left crash bar.

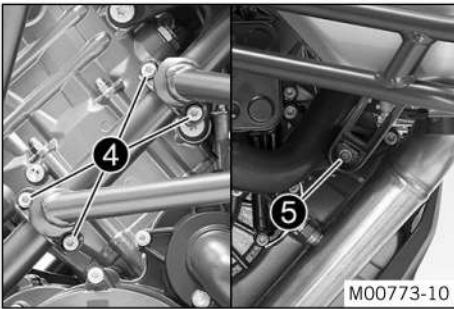

- Remove screws ④ and take off the clamp halves.
- Remove screw ⑤.
- Take off the right crash bar.

## 7.4 Installing the crash bar

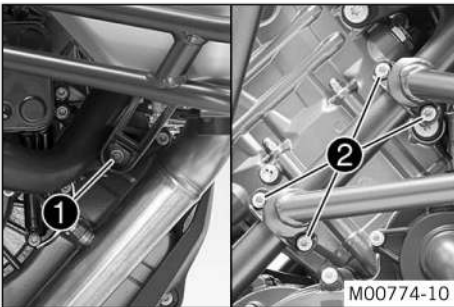

- Position the right crash bar with the frame protector.
- ✓ The fuel tank support ring should be correctly positioned on the fuel tank.



**Info**

Cover the components to protect them against damage.

- Mount screw ①, but do not tighten yet.

Guideline

Remaining chassis screws	M8	25 Nm (18.4 lbf ft)
--------------------------	----	------------------------

- Mount screws ②, but do not tighten yet.

Guideline

Remaining chassis screws	M6	10 Nm (7.4 lbf ft)
--------------------------	----	--------------------

- Position the left crash bar with the frame protector.
- ✓ The fuel tank support ring should be correctly positioned on the fuel tank.



**Info**

Cover the components to protect them against damage.

- Mount screw ③, but do not tighten yet.

Guideline

Remaining chassis screws	M8	25 Nm (18.4 lbf ft)
--------------------------	----	------------------------

- Mount screws ④, but do not tighten yet.

Guideline

Remaining chassis screws	M6	10 Nm (7.4 lbf ft)
--------------------------	----	--------------------

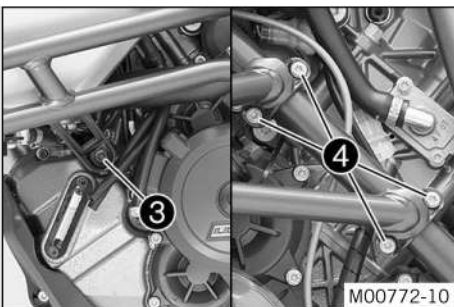



- Mount and tighten fittings 5.

Guideline

Remaining chassis screws	M6	10 Nm (7.4 lbf ft)
--------------------------	----	--------------------

✓ The crash bars are evenly aligned with each other.

- Tighten all the screws of the crash bar.

Guideline

Remaining chassis screws	M6	10 Nm (7.4 lbf ft)
Remaining chassis screws	M8	25 Nm (18.4 lbf ft)

## 7.5 Changing the throttle grip

### Preparatory work

- Switch off all power consumers and switch off the engine.
- Remove the wind shield. (p. 94)
- Remove the passenger seat. (p. 72)
- Remove the front rider's seat. (p. 71)
- Remove the crash bar. (p. 32)
- Remove the front side cover. (p. 87)
- Remove the tank cover. (p. 89)
- Remove the mask spoiler. (p. 90)
- Remove the headlight mask with the headlight. (p. 145)

### Main work

- Remove intake snorkel 1.

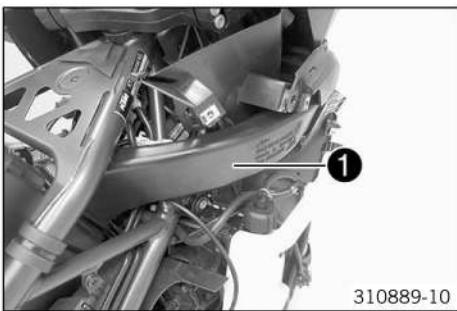

- Remove the cable tie(s).



- Remove the cable tie(s).

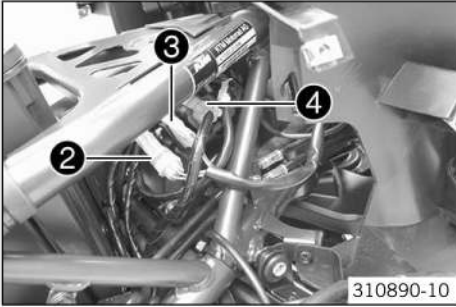

- Disconnect plug-in connector ②.
- Remove plug-in connectors ③ and ④ from the holder and disconnect.

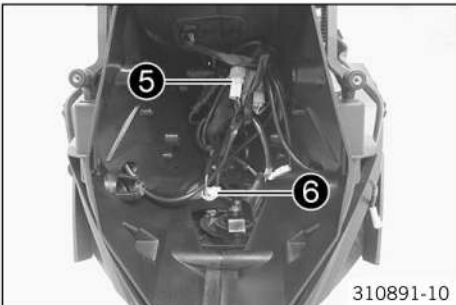

- Disconnect plug-in connector ⑤.
- Disconnect plug-in connector ⑥.
- Slip out the cables.

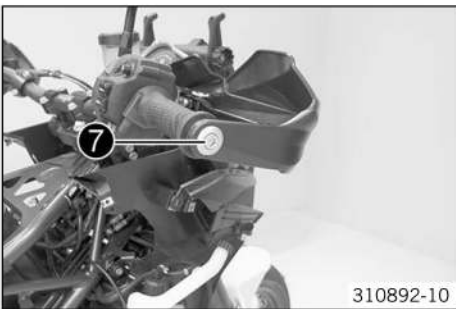

- Loosen screw ⑦.
- Push the hand guard slightly to the side.

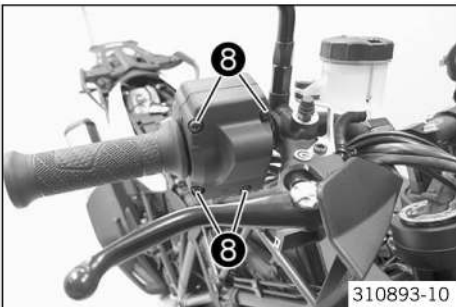

- Remove screws ⑧.



- Take off throttle grip with sensor unit.

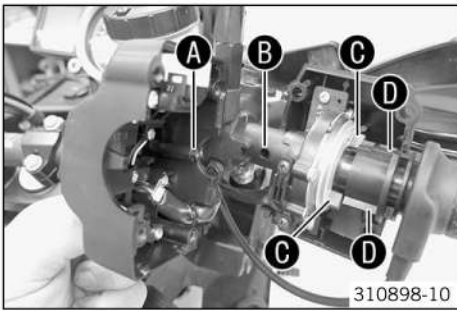

- Position throttle grip with sensor unit.
- ✓ Pin **A** engages in hole **B**.
- ✓ Projections **C** engage in recesses **D**.

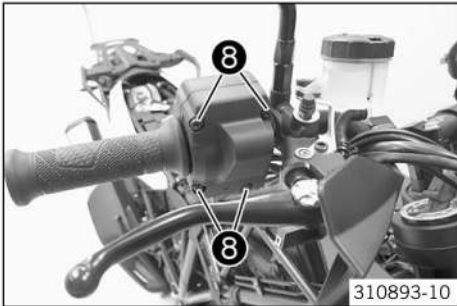

- Mount and tighten screws **8**.

Guideline

Remaining screws, chassis	M5	5 Nm (3.7 lbf ft)
---------------------------	----	-------------------

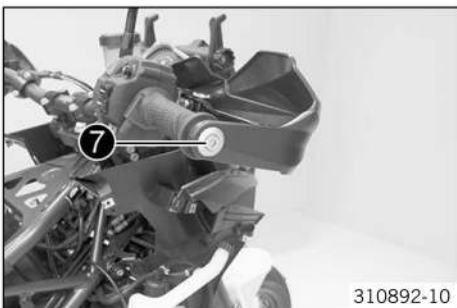

- Position hand guard.
- Tighten screw **7**.

Guideline

Hand guard screw	M8	15 Nm (11.1 lbf ft)
------------------	----	------------------------

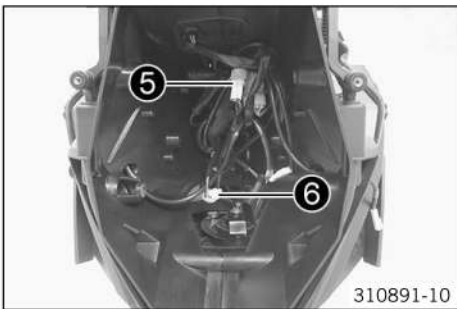

- Join plug-in connector **5**.
- Join plug-in connector **6**.
- Route the cable without tension.

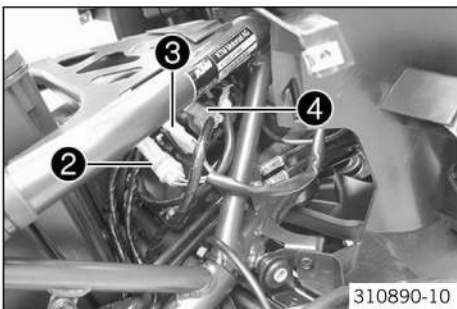

- Join plug-in connector **2**.
- Join plug-in connectors **3** and **4** and position them in the holder.



- Route the cable without tension and secure with cable tie(s).

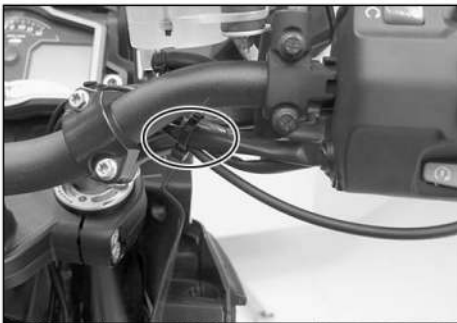

- Route the cable without tension and secure with cable ties.



310887-10

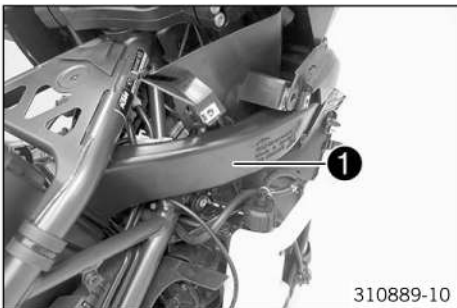

- Mount intake snorkel ①.



**Info**

Ensure that the seals are seated correctly.

**Finishing work**

- Install the headlight mask with the headlight. (p. 145)
- Install the mask spoiler. (p. 92)
- Install the tank cover. (p. 89)
- Install the front side cover. (p. 87)
- Install the crash bar. (p. 32)
- Mount the front rider's seat. (p. 71)
- Mount the passenger seat. (p. 72)
- Install the wind shield. (p. 95)
- Check the setting of the lighting system. (p. 148)
- Program the switch for the cruise control system. (p. 152)

## 7.6 Replacing the heated grips

**Preparatory work**

- Switch off all power consumers and switch off the engine.
- Remove the wind shield. (p. 94)
- Remove the passenger seat. (p. 72)
- Remove the front rider's seat. (p. 71)
- Remove the crash bar. (p. 32)
- Remove the front side cover. (p. 87)
- Remove the tank cover. (p. 89)
- Remove the mask spoiler. (p. 90)
- Remove the headlight mask with the headlight. (p. 145)

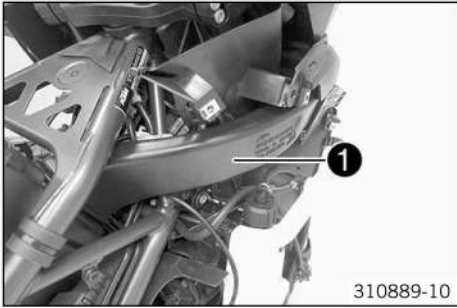

**Main work**

- Remove intake snorkel ①.



- Remove the cable tie(s).



- Remove the cable tie(s).



- Remove the cable tie(s).



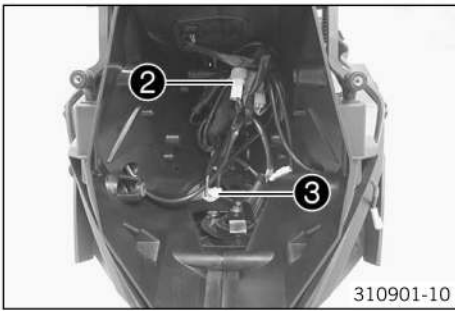

- Disconnect plug-in connector ②.
- Slip out cables.
- Disconnect plug-in connector ③.
- Slip out cables.

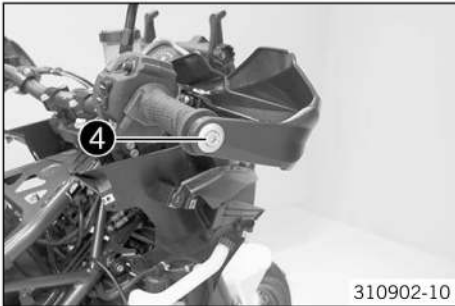

- Loosen screw ④.
- Push the hand guard slightly to the side.

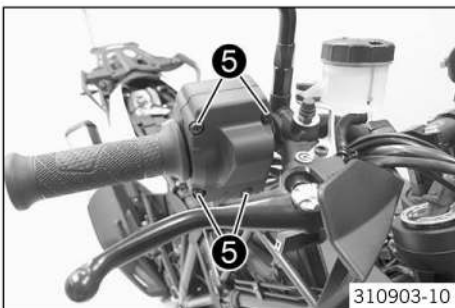

- Remove screws ⑤.



- Pull off throttle grip with sensor unit from the handlebar.
- Remove the throttle grip.



**Info**

The sensor unit must not be disconnected. If the sensor unit is disconnected, the switch of the speed control system must be programmed.

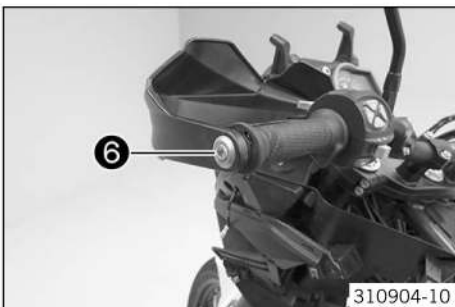

- Loosen screw ⑥.
- Push the hand guard slightly to the side.

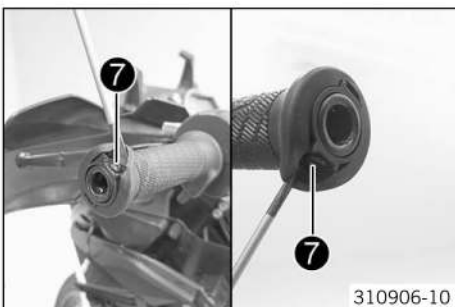

- Slightly raise the rubber grip.
- Remove screw ⑦.





- Take off heated grip.

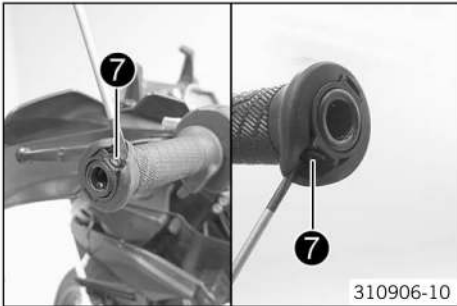

- Position heated grip.
- Slightly raise the rubber grip.
- Mount and tighten screw 7.

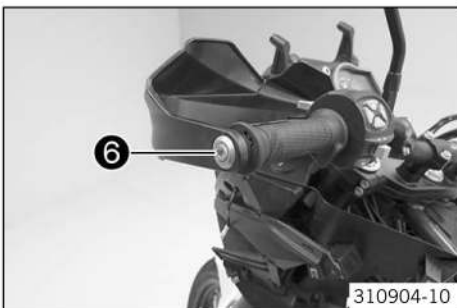

- Position hand guard.
- Tighten screw 6.

Guideline

Hand guard screw	M8	15 Nm (11.1 lbf ft)
------------------	----	------------------------

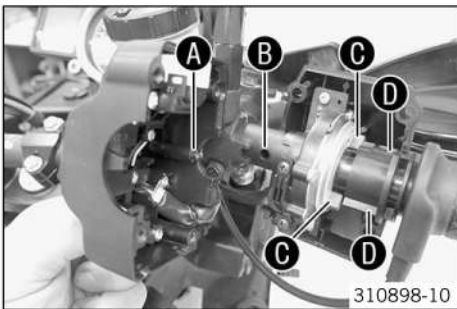

- Position throttle grip with sensor unit.
- ✓ Pin A engages in hole B.
- ✓ Projections C engage in recesses D.

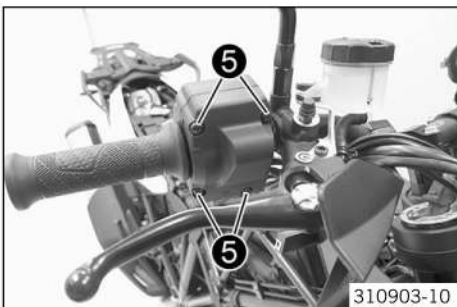

- Mount and tighten screws 5.

Guideline

Remaining chassis screws	M6	10 Nm (7.4 lbf ft)
--------------------------	----	--------------------

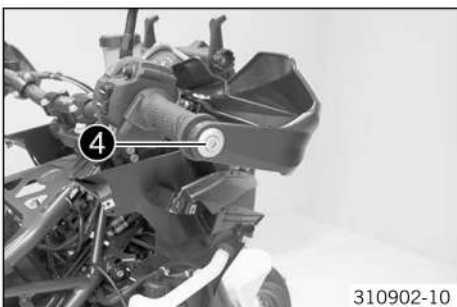

- Position hand guard.
- Tighten screw 4.

Guideline

Hand guard screw	M8	15 Nm (11.1 lbf ft)
------------------	----	------------------------

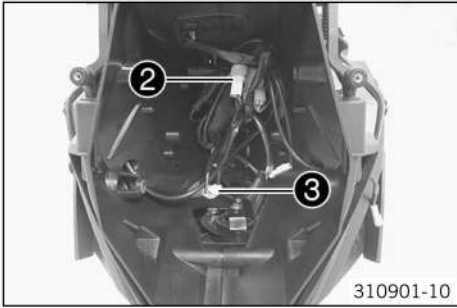

- Connect plug-in connector ③.
- Route the cable without tension.
- Connect plug-in connector ②.
- Route the cable without tension.

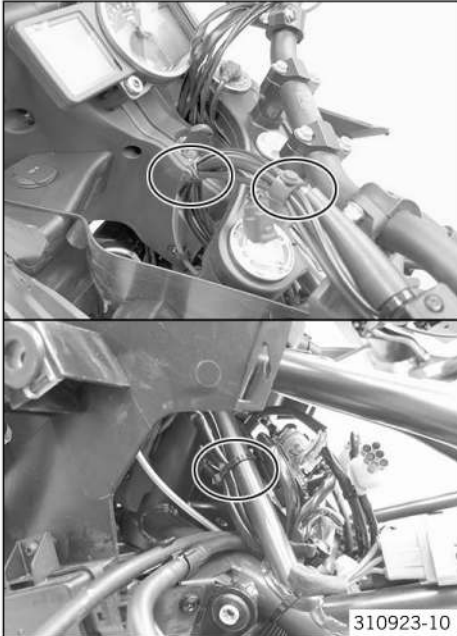

- Route the cable without tension and secure with a cable binder.



- Route the cable without tension and secure with a cable binder.

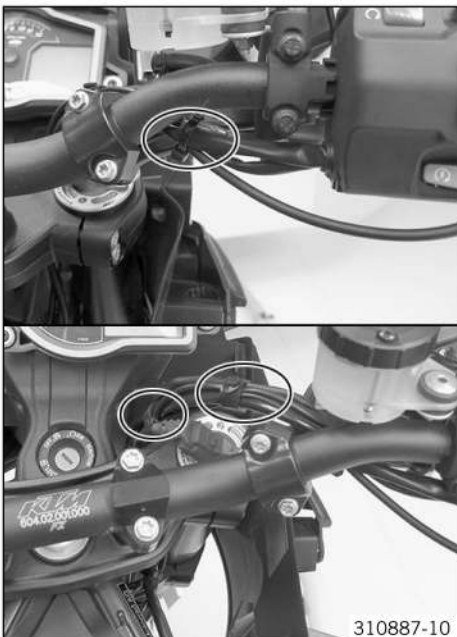

- Route the cable without tension and secure with a cable binder.



- Mount intake snorkel ①.

**Info**

Ensure that the seals are seated correctly.

**Finishing work**

- Install the headlight mask with the headlight. (📖 p. 145)
- Install the mask spoiler. (📖 p. 92)
- Install the tank cover. (📖 p. 89)
- Install the front side cover. (📖 p. 87)
- Install the crash bar. (📖 p. 32)
- Mount the front rider's seat. (📖 p. 71)
- Mount the passenger seat. (📖 p. 72)
- Install the wind shield. (📖 p. 95)
- Check the setting of the lighting system. (📖 p. 148)

## 8.1 Rider footrests

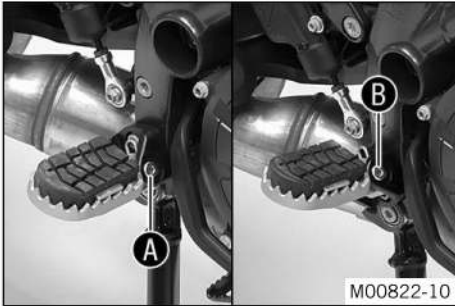

The rider footrests can be mounted in one of two positions.

### Possible states

- Rider footrests, low **A**
- Rider footrests, high **B**

## 8.2 Adjusting the footrests



### Info

The operations on the footrest brackets are the same for the left and right sides.



- Remove screw **1**.
- ✓ The foot brake lever swings up to the stop.

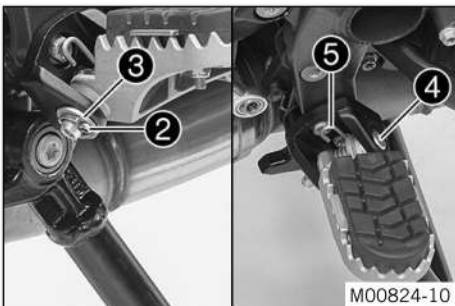

- Remove cotter pin **2** with washer **3**.
- Carefully remove the pin **4** of the rider footrest.



### Info

The spring is under high tension and can pop out when the pin is removed.

- Take off the rider footrest **5** with the spring.

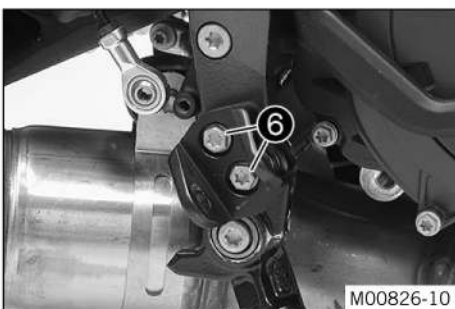

- Remove screws **6**.

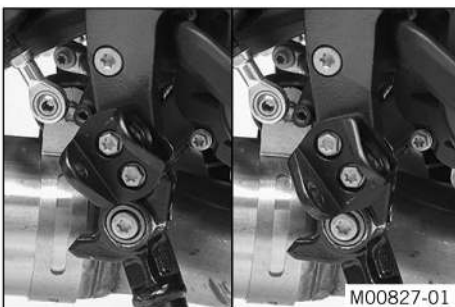

- Adjust the footrest bracket to the desired position.

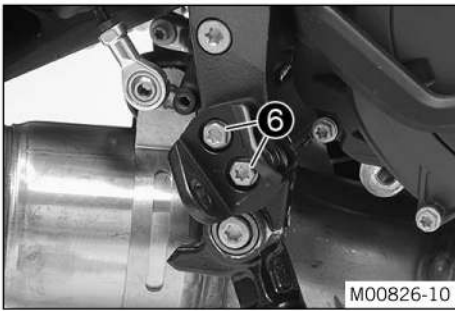

- Mount and tighten screws **6**.

Guideline

Screw, front footrest bracket	M8	25 Nm (18.4 lbf ft)	Loctite® 243™
-------------------------------	----	---------------------	---------------

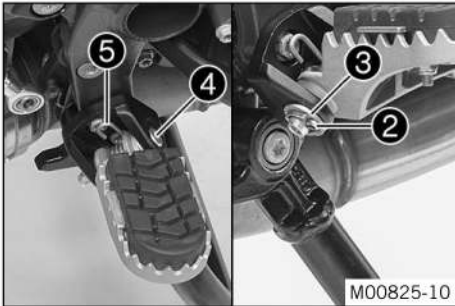

- Mount the rider footrest with spring **5** and pin **4**.

Pliers for footrest spring (58429083000) (📖 p. 344)
---

- Mount washer **3** and cotter pin **2**.

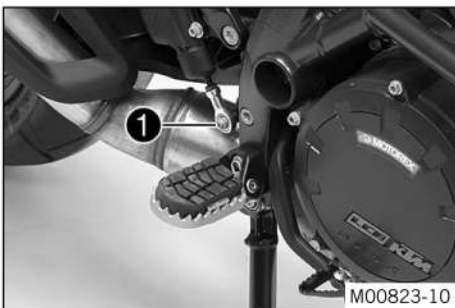

- Position the foot brake lever.
- Mount and tighten screw **1**.

Guideline

Screw, ball joint of push rod on foot brake cylinder	M6	10 Nm (7.4 lbf ft)	Loctite® 243™
--	----	--------------------	---------------

### 8.3 Removing the engine guard

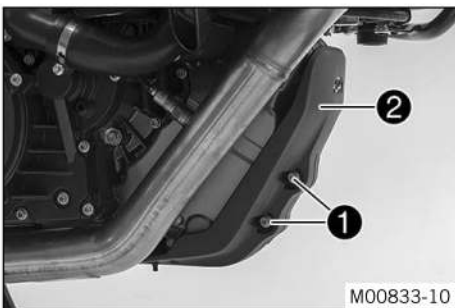

- Remove screws **1** with bushings and engine guard **2**.

### 8.4 Installing the engine guard

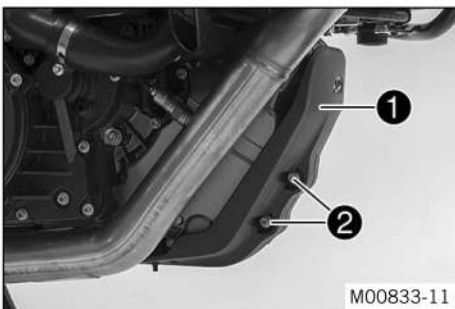

- Position engine guard **1**, mount screws **2** with bushings and tighten.

Guideline

Screw, engine guard	M6	10 Nm (7.4 lbf ft)
---------------------	----	--------------------

## 8.5 Checking the frame



- Check the frame for cracks and deformation.
  - » If the frame exhibits cracks or deformation due to a mechanical impact:
    - Change the frame.

**Info**

Always replace a frame that has been damaged due to a mechanical impact. Repair of the frame is not authorized by KTM.

---

## 9.1 Measuring the rear wheel dimension unloaded

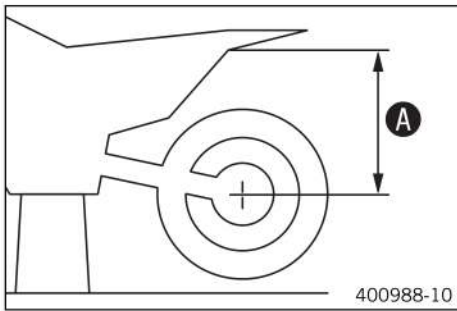

### Preparatory work

- Raise the vehicle with the center stand. (📖 p. 12)

### Main work

- Measure the distance – as vertical as possible – between the rear axle and a fixed point, for example, a mark on the rear fairing.
- Note down the value as dimension **A**.

### Finishing work

- Remove the vehicle from the center stand. (📖 p. 12)

## 9.2 Checking the static sag of the shock absorber

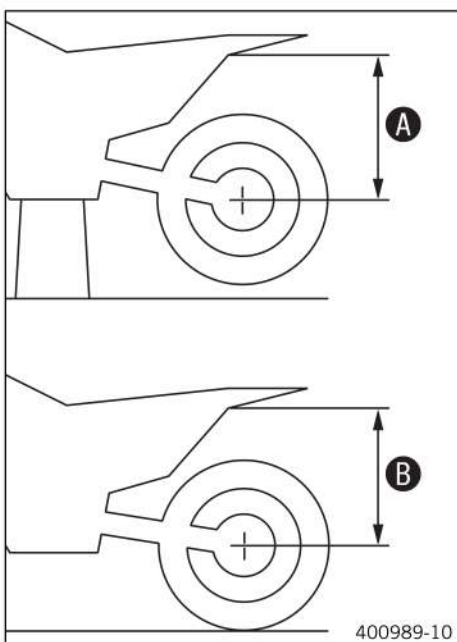

- Measure dimension **A** of rear wheel unloaded. (📖 p. 45)
- Hold the motorcycle upright with the aid of an assistant.
- Measure the distance between the rear axle and the fixed point again.
- Note down the value as dimension **B**.



### Info

The static sag is the difference between measurements **A** and **B**.

- Check the static sag.

Full fuel tank	25 mm (0.98 in)
Empty fuel tank	20 mm (0.79 in)

- » If the static sag is less or more than the specified value:
  - Adjust the spring pretension of the shock absorber. (📖 p. 45)

## 9.3 Adjusting the spring pretension of the shock absorber



### Condition

The diagnostic tool is connected and running.

- Execute "Damping system - SCU" > "Functions" > "Adjusting offset for sag".
- Following the instructions in KTM diagnostics tool exactly.

## 9.4 Removing the shock absorber

### Preparatory work

- Raise the vehicle with the center stand. (📖 p. 12)
- Remove the passenger seat. (📖 p. 72)
- Remove the front rider's seat. (📖 p. 71)

### Main work

- Remove screw ❶.
- Lower the swingarm.

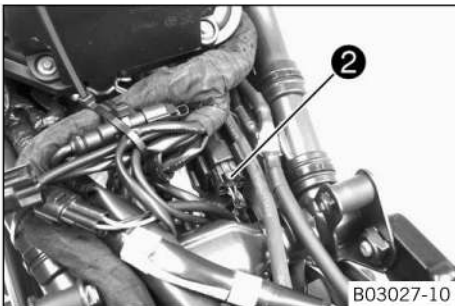
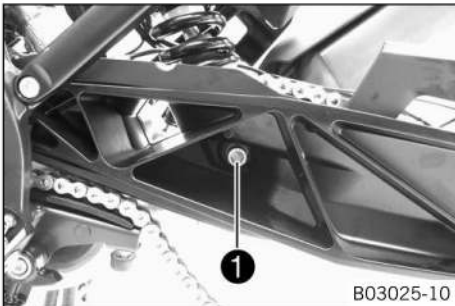

- Unplug connector ❷.
- Maneuver the wiring harness out.



- Unplug connector ❸.

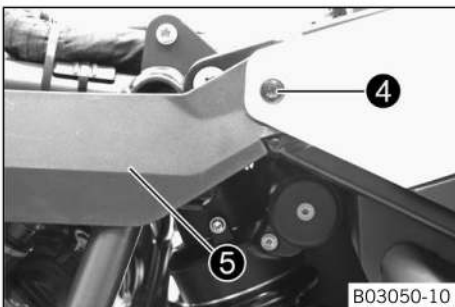

- Remove screw ❹.
- Lift up heat protector ❺.

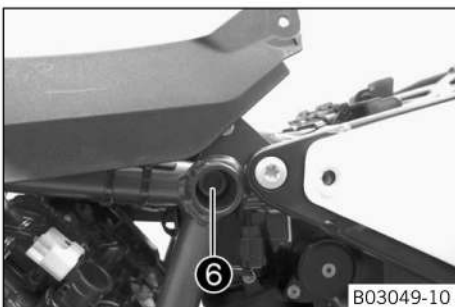

- Remove screw ❻.
- Lower the shock absorber.



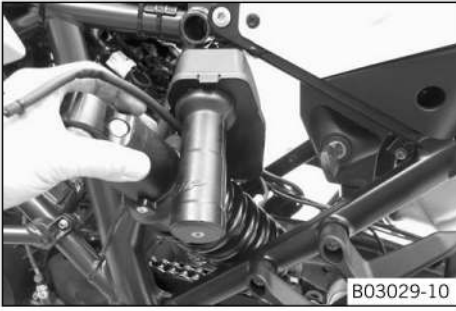

B03029-10

- Remove the shock absorber.

## 9.5 Installing the shock absorber

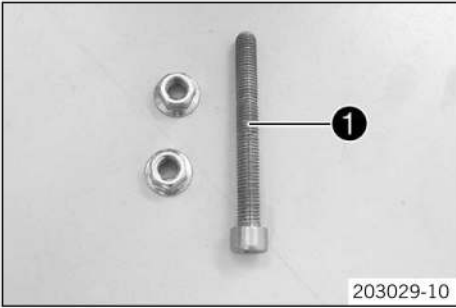

203029-10

### Main work

- Use a commercially-available screw **1** and 2 collar nuts.

#### Guideline

Screw	M10
Length	≥ 60 mm (≥ 2.36 in)

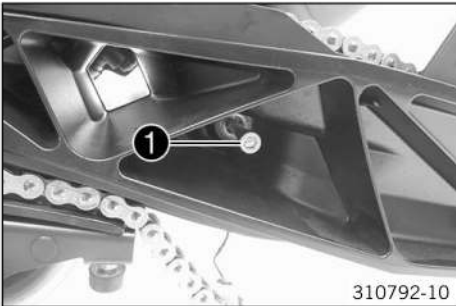

310792-10

- Position screw **1** in the drill hole of the swingarm.

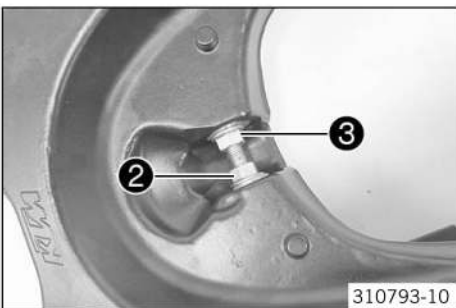

310793-10

- Mount both collar nuts **2** and **3** with the collar facing out.
- Hold screw **1**. Tighten collar nut **2** until it is in contact with the swingarm.
  - ✓ Screw **1** rests against the swingarm at collar nut **3**.
  - ✓ The centering bushing of the shock absorber is pressed into the swingarm.
- Remove the screw and nuts.



B03029-10

- Position the shock absorber.

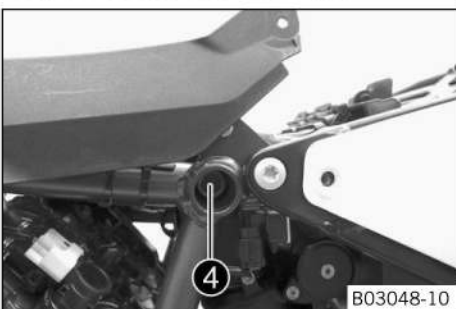

B03048-10

- Mount and tighten screw **4**.

#### Guideline

Screw, top shock absorber	M14x1.5	80 Nm (59 lbf ft)	Thread greased
---------------------------	---------	----------------------	----------------

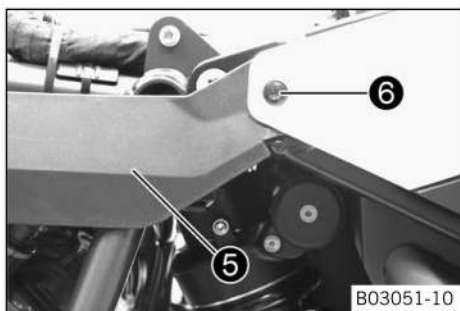

- Position heat protector ⑤.
- Mount and tighten screw ⑥.

Guideline

Screw, cover part	M5	3.5 Nm (2.58 lbf ft)
-------------------	----	-------------------------

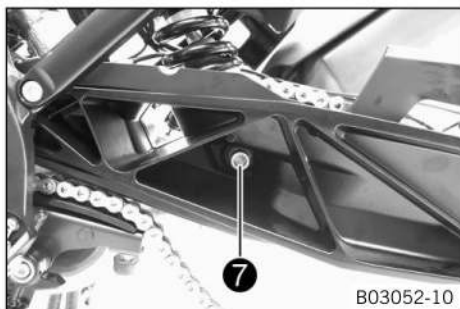

- Lift the swingarm and position the shock absorber.
- Mount and tighten screw ⑦.

Guideline

Screw, bottom shock absorber	M14x1.5	80 Nm (59 lbf ft)	Thread greased
------------------------------	---------	----------------------	----------------



- Position the wiring harness.
- Plug in connector ⑧.

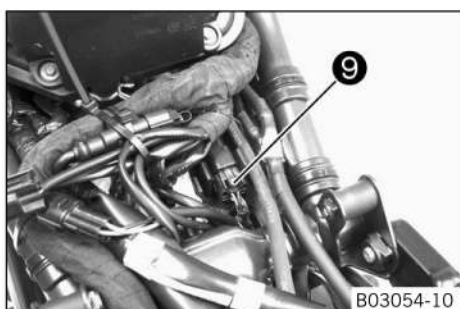

- Position the wiring harness.
- Plug in connector ⑨.

### Finishing work

- Program the shock absorber control motor. (📖 p. 59)
- Mount the front rider's seat. (📖 p. 71)
- Mount the passenger seat. (📖 p. 72)
- Remove the vehicle from the center stand. (📖 p. 12)

## 9.6 Removing the spring

### Condition

The shock absorber has been removed.

- Clamp the shock absorber into the special tool.

Spring compressor (T14050S) (📖 p. 357)
--



### Info

Use a fitting washer of the special tool as a spring pad.

- Compress the spring. Remove spring retainer ①.

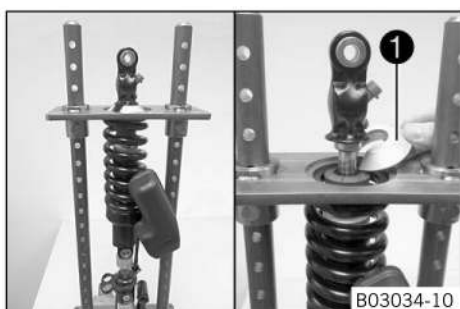

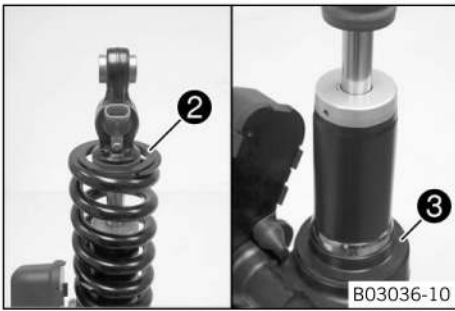

- Release the spring. Unclamp the shock absorber.
- Remove washer ② and spring.
- Remove washer ③.

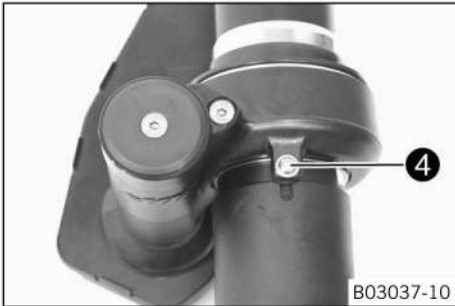

- Remove preload adjuster.



**Info**

Screw ④ does not need to be loosened.

## 9.7 Installing the spring

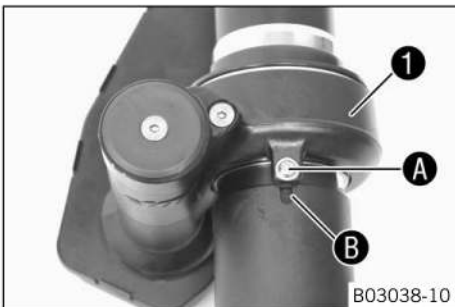

- Mount preload adjuster ①.
- ✓ Screw ① is aligned with recess ②.

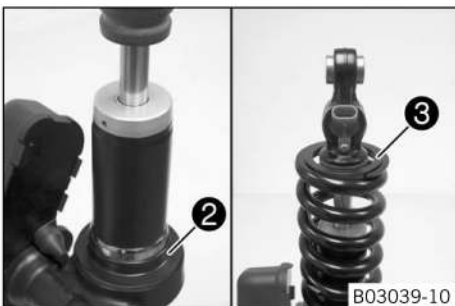

- Mount washer ②.
- Position spring and washer ③.

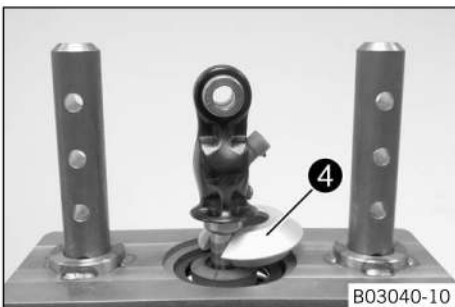

- Clamp the shock absorber into the special tool.

Spring compressor (T14050S) (p. 357)



**Info**

Use a fitting washer of the special tool as a spring pad.

- Compress the spring. Mount spring retainer ④.
- Release the spring. Unclamp the shock absorber.

## 9.8 Removing the heim joint

**i Info**  
The operations are the same for the top and bottom heim joints.

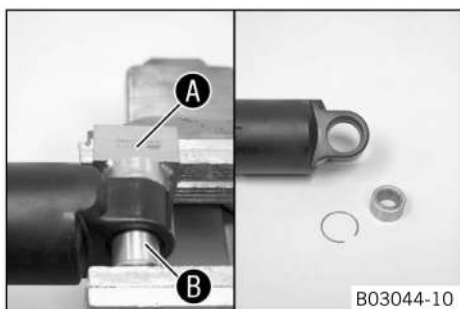
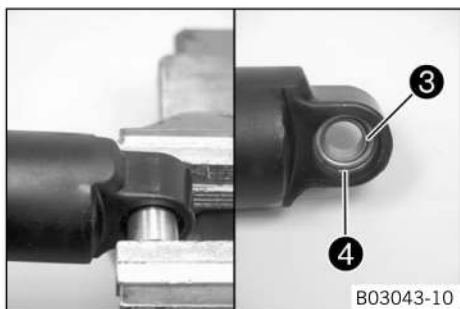
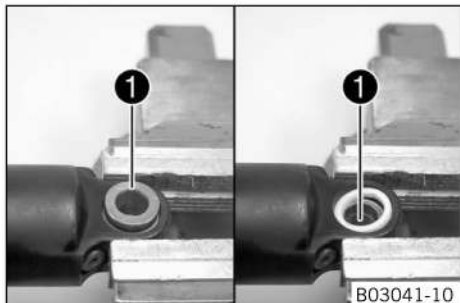

**Condition**

The shock absorber has been removed.

- Clamp the shock absorber into the vise with soft jaws.
- Remove both collar bushings ① of the heim joint with a drift.

Pin (T120) (p. 356)

- Remove seal rings ② on both sides.

- Press heim joint ③ to the side.

Pressing tool (T1207S) (p. 356)

- ✓ The heim joint rests against a lock ring.
- Remove the other lock ring ④.

- Place special tool A underneath and press out the heim joint with special tool B.

Pressing tool (T1207S) (p. 356)

## 9.9 Installing the heim joint

**i Info**  
The operations are the same for the top and bottom heim joints.

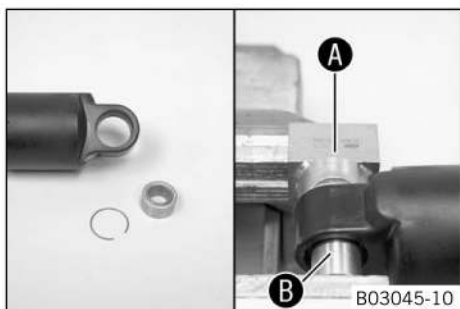

- Place special tool **A** underneath and press out the heim joint up to the lock ring with special tool **B**.

Pressing tool (T1207S) (📖 p. 356)

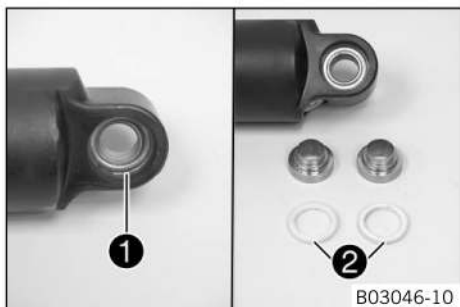

- Mount a second lock ring **1**.
- Mount seal rings **2** on both sides and grease.

Lubricant (T158) (📖 p. 340)

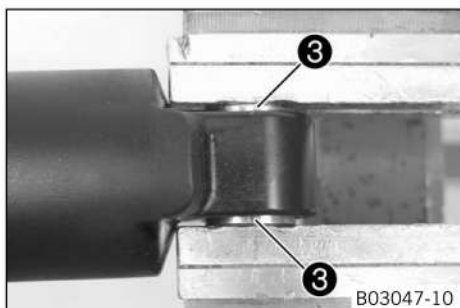

- Press in both collar bushings **3** of the heim joint.

## 9.10 Checking the swingarm

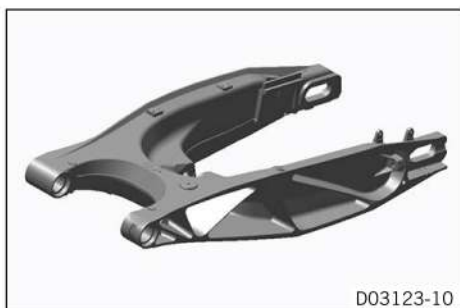

- Check the swingarm for damage, cracking, and deformation.
  - » If the swingarm shows signs of damage, cracking, or deformation:
    - Change the swingarm.



### Info

Always change a damaged swingarm. Repair of the swingarm is not authorized by KTM.

## 9.11 Checking the swingarm bearing for play

### Preparatory work

- Raise the vehicle with the center stand. (📖 p. 12)
- Place a load on the front of the vehicle.
  - ✓ The rear wheel is not in contact with the ground.

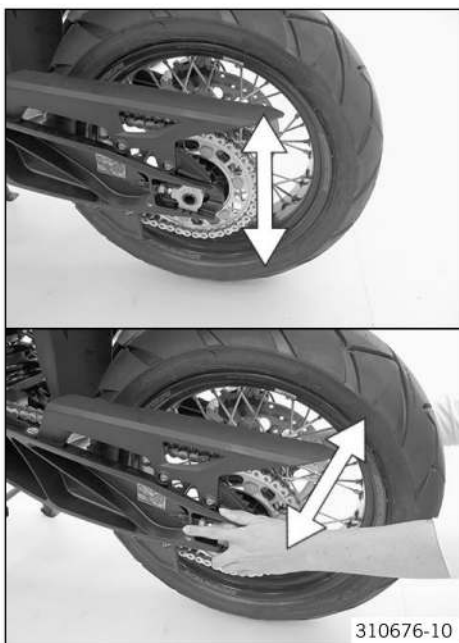

**Main work**

- Move the swingarm up and down.
  - » If there is detectable play:
    - Change the swingarm bearing. (📖 p. 54)
- Move the swingarm from one side to the other.
  - » If there is detectable play:
    - Change the swingarm bearing. (📖 p. 54)

## 9.12 Removing the swingarm

**Preparatory work**

- Raise the vehicle with the center stand. (📖 p. 12)
- Remove the rear wheel. (📖 p. 107)

**Main work**

- Remove screws ❶. Remove the splash protector.

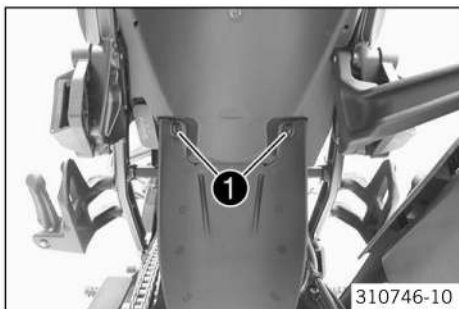

- Remove screw ❷.
- Take off the cable holder.

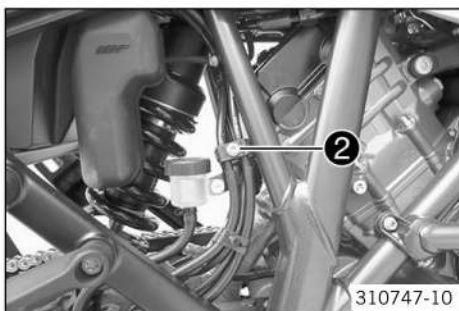

- Remove screws ❸.
- Remove screw ❹.
- Hang the foot brake cylinder to the side.

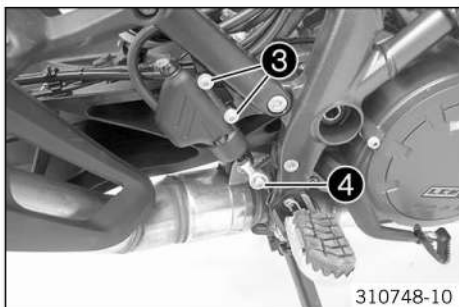

# 9 SHOCK ABSORBER, SWINGARM

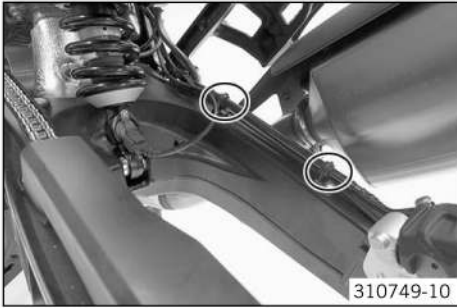

- Take the brake line out of the holders.

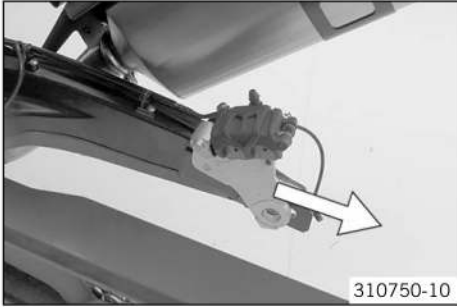

- Pull brake caliper back and hang to the side.

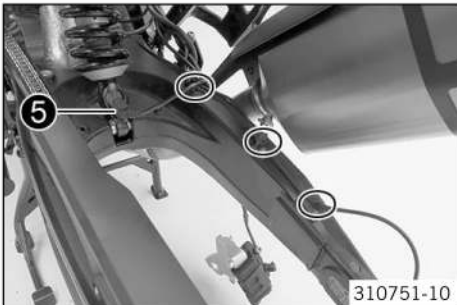

- Take the cable out of holders.
- Unplug connector ⑤.

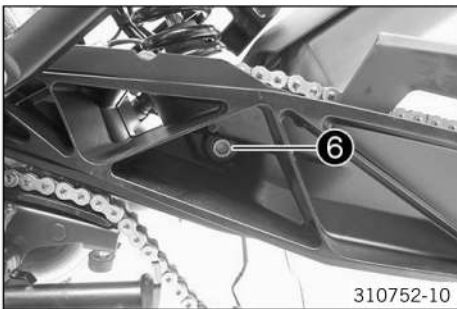

- Remove screw ⑥.
- Push the swingarm down and away from the shock absorber.

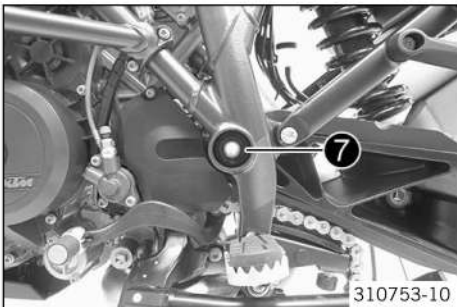

- Remove nut ⑦.

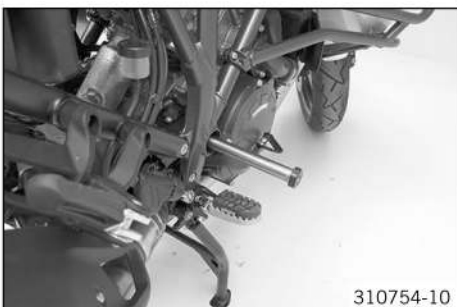

- Remove the swingarm pivot. Take off the swingarm.

## 9.13 Changing the swingarm bearing

### Preparatory work

- Raise the vehicle with the center stand. (📖 p. 12)
- Remove the rear wheel. (📖 p. 107)
- Remove the swingarm. (📖 p. 52)

### Right swingarm bearing

- Remove the outer collar bushing **1**.
- Remove the inner collar bushing **2** together with the bushing.

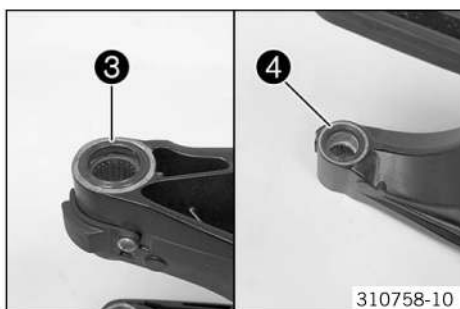
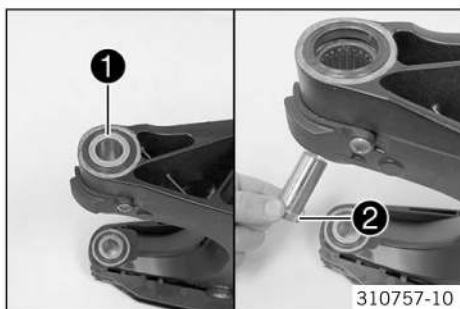

- Remove the shaft seal rings **3** and **4**.

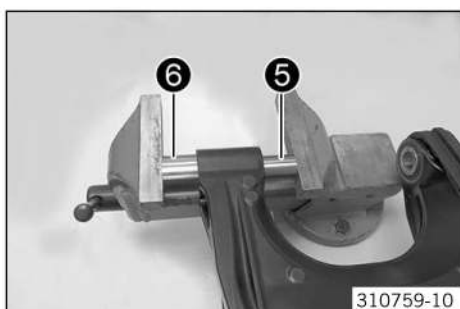

- Position special tool **5** in the needle bearing from the inside.

Press drift, swingarm bearing (61329004100) (📖 p. 351)

- Position special tool **6** on the swingarm from the outside.

Counterholder, swingarm bearing (61329004200) (📖 p. 351)

- Push out the needle bearing.

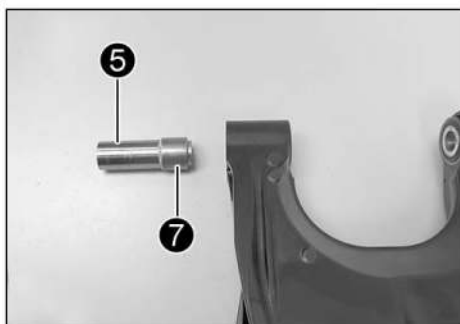

- Position the new needle bearing **7** on special tool **5**.

Press drift, swingarm bearing (61329004100) (📖 p. 351)

- Position the special tool with the bearing on the swingarm from the outside.
- Push in the needle bearing until it is flush.





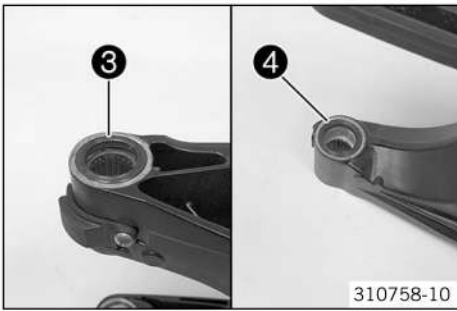

- Grease shaft seal rings ③ and ④ and press in until flush.

Long-life grease (📖 p. 340)

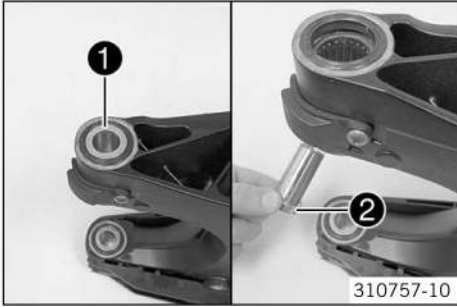

- Grease the needle bearing.

Long-life grease (📖 p. 340)

- Mount the inner collar bushing ② together with the bushing.
- Mount the outer collar bushing ①.

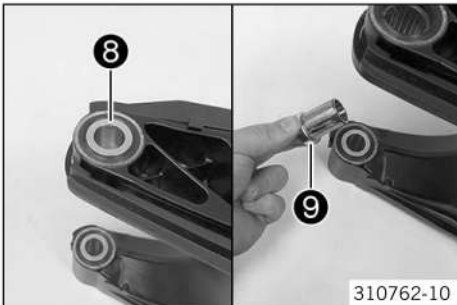

### Left swingarm bearing

- Remove the outer collar bushing ⑧.
- Remove the inner collar bushing ⑨ together with the bushing.

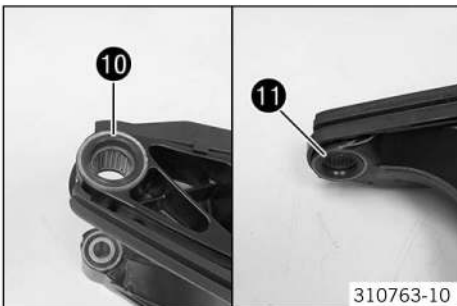

- Remove the shaft seal rings ⑩ and ⑪.

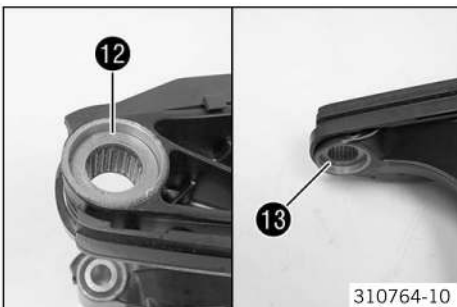

- Remove stop disks ⑫ and ⑬.

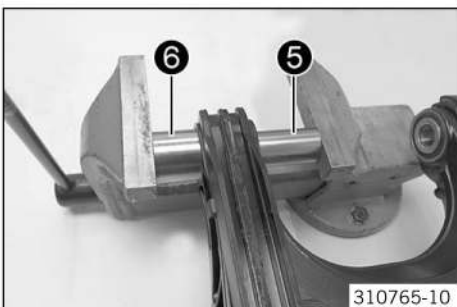

- Position special tool ⑤ in the needle bearing.

Press drift, swingarm bearing (61329004100) (📖 p. 351)

- Position special tool ⑥ in the swingarm.

Counterholder, swingarm bearing (61329004200) (📖 p. 351)

- Push out the needle bearing.

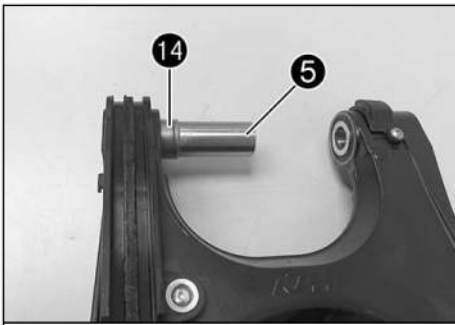

- Position the new needle bearing 14 on special tool 5.

Press drift, swingarm bearing (61329004100) (📖 p. 351)

- Position the special tool with the bearing on the swingarm.
- Push in the needle bearing until it is flush.

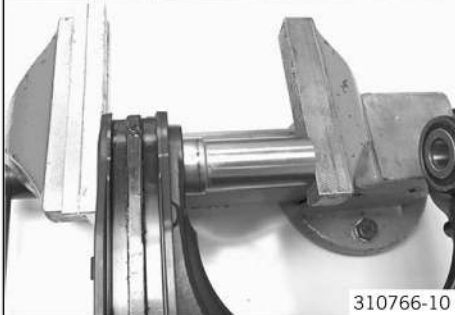

310766-10

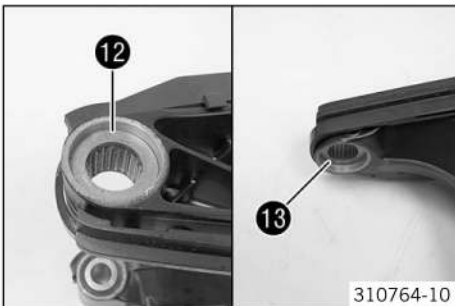

310764-10

- Position stop disks 12 and 13.

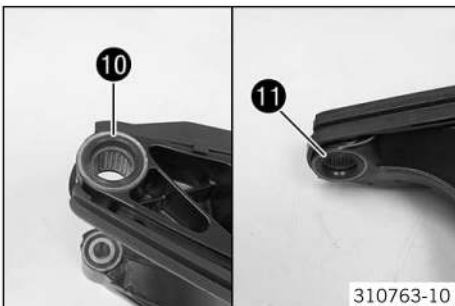

310763-10

- Grease shaft seal rings 10 and 11 and press in until flush.

Long-life grease (📖 p. 340)

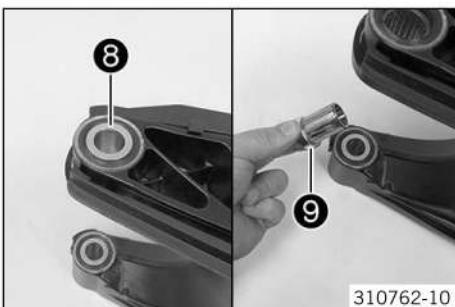

310762-10

- Grease the needle bearing.
- Mount the inner collar bushing 9 together with the bushing.
- Mount the outer collar bushing 8.

Long-life grease (📖 p. 340)

### Finishing work

- Install the swingarm. (📖 p. 57)
- Install the rear wheel. (📖 p. 108)
- Adjust the chain tension. (📖 p. 115)
- Remove the vehicle from the center stand. (📖 p. 12)
- Program the swing angle sensor. (📖 p. 59)

## 9.14 Installing the swingarm



### Main work

- Position the swingarm. Mount the swingarm pivot.

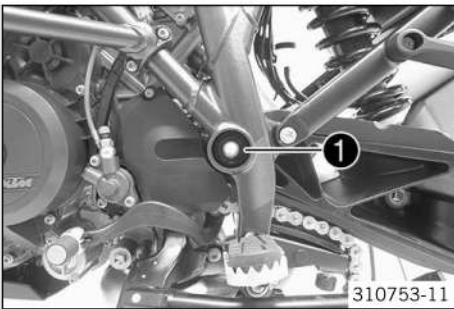

- Mount and tighten nut **1**.

#### Guideline

Nut, swingarm pivot	M19x1.5	130 Nm (95.9 lbf ft)	Thread greased
---------------------	---------	-------------------------	----------------

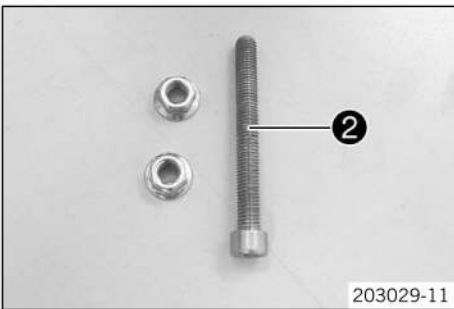

- Use a commercially-available screw **2** and 2 collar nuts.

#### Guideline

Screw	M10
Length	≥ 60 mm (≥ 2.36 in)

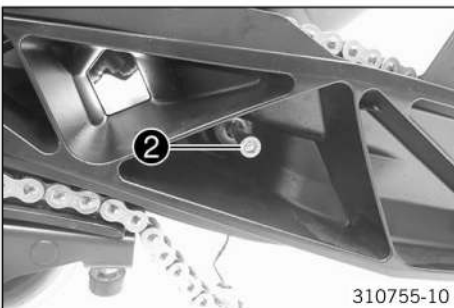

- Position screw **2** in the drill hole of the swingarm.

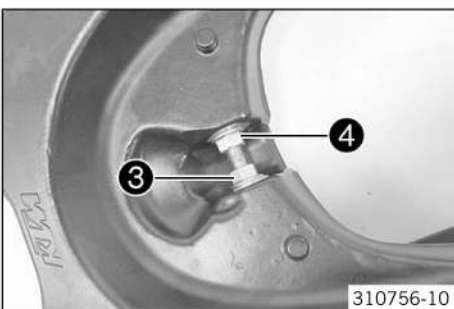

- Mount both collar nuts **3** and **4** with the collar facing out.
- Counterhold screw **2**. Tighten collar nut **3** until it is in contact with the swingarm.
  - ✓ Screw **2** rests against the swingarm at collar nut **4**.
  - ✓ The centering bushing of the shock absorber is pressed into the swingarm.
- Remove the screw and nuts.

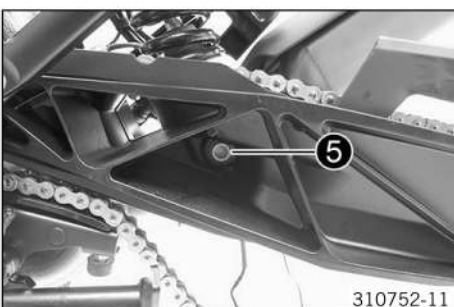

- Lift the swingarm and position the shock absorber.
- Mount and tighten screw **5**.

#### Guideline

Screw, bottom shock absorber	M14x1.5	80 Nm (59 lbf ft)	Thread greased
------------------------------	---------	----------------------	----------------

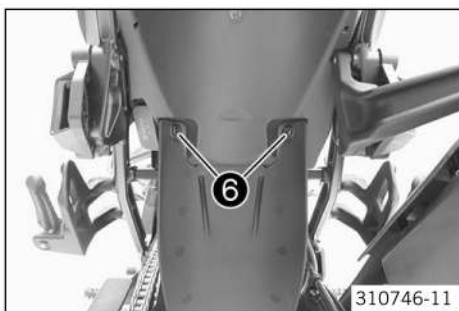

- Position the splash protector.
- Mount and tighten screws **6**.

Guideline

Remaining screws, chassis	M5	5 Nm (3.7 lbf ft)
---------------------------	----	-------------------

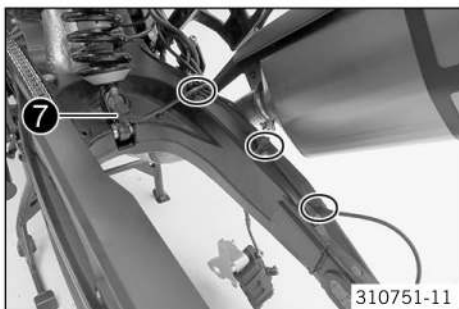

- Plug in connector **7**.
- Secure the cable in the holders.

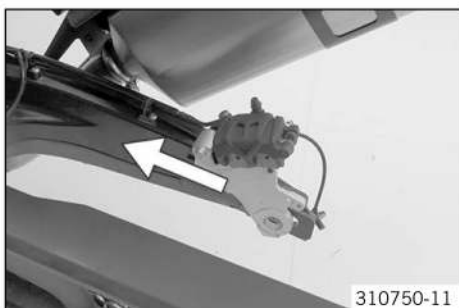

- Position the brake caliper.

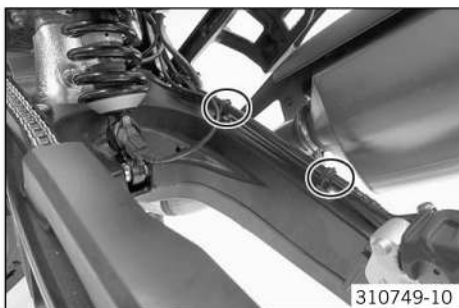

- Secure the brake line in the holders.

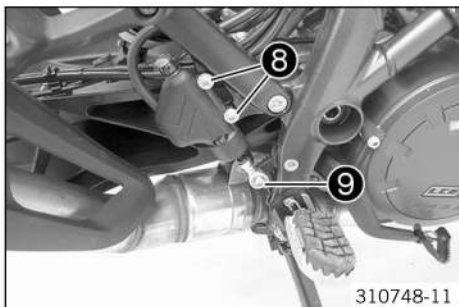

- Position the foot brake cylinder.
- Mount and tighten screws **8**.

Guideline

Screw, foot brake cylinder	M6	10 Nm (7.4 lbf ft)	Loctite® 243™
----------------------------	----	--------------------	---------------

- Mount and tighten screw **9**.

Guideline

Screw, ball joint of push rod on foot brake cylinder	M6	10 Nm (7.4 lbf ft)	Loctite® 243™
--	----	--------------------	---------------

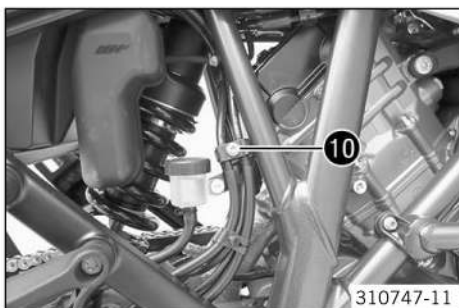

- Position the cable holder.
- Mount and tighten screw **10**.

Guideline

Remaining chassis nuts	M6	10 Nm (7.4 lbf ft)
------------------------	----	--------------------

### Finishing work

- Install the rear wheel. (📖 p. 108)

- Adjust the chain tension. (📖 p. 115)
- Remove the vehicle from the center stand. (📖 p. 12)
- Program the swing angle sensor. (📖 p. 59)

## 9.15 Programming the shock absorber control motor



401898-01

### Condition

The diagnostic tool is connected and running.

- Execute "**Damping system**" > "**Functions**" > "**Factory calibration**".

### Info

The instructions must be followed precisely.

- Clear the fault memory using the KTM diagnostics tool.
  - » Take a test ride.
    - Read out the trouble code memory using the KTM diagnostics tool.

## 9.16 Programming the swing angle sensor



401898-01

### Condition

The diagnostic tool is connected and running.

- Execute "**Damping system**" > "**Functions**" > "**Rear suspension travel sensor calibration**".

### Info

The instructions must be followed precisely.

- Clear the fault memory using the KTM diagnostics tool.
  - » Take a test ride.
    - Read out the trouble code memory using the KTM diagnostics tool.

## 10.1 Disassembling the main silencer

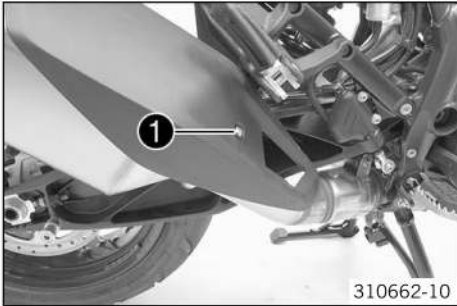

- Remove screw **1**.
- Pull off the heat protector toward the front.

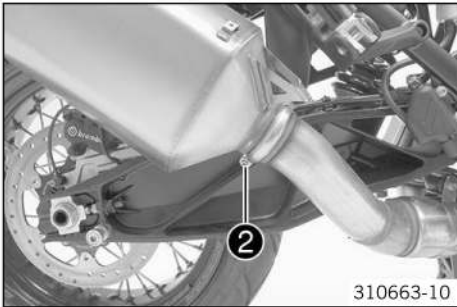

- Remove screw **2**.
- Remove the exhaust clamp.

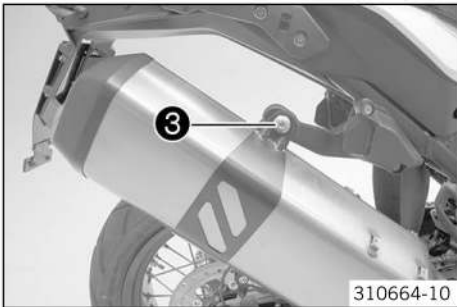

- Remove screw **3** with the washer.
- Remove the main silencer with the main silencer clamp.

## 10.2 Installing the main silencer



- Position the main silencer with the main silencer clamp.
- Mount screw **1** with the washer but do not tighten yet.

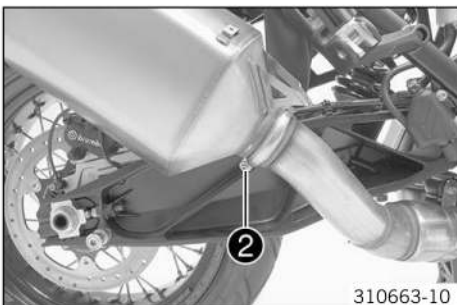

- Position the exhaust clamp.
- Mount and tighten screw **2**.

### Guideline

Screw, exhaust clamp	M6	8 Nm (5.9 lbf ft)
----------------------	----	-------------------

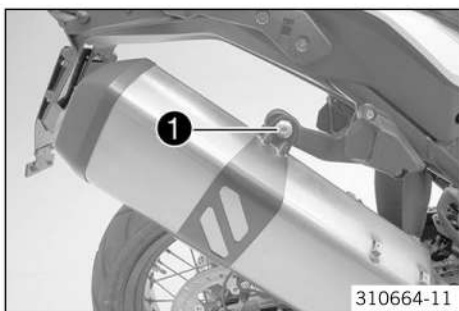

- Tighten screw 1.

Guideline

Screw, exhaust clamp	M8	25 Nm (18.4 lbf ft)
----------------------	----	------------------------

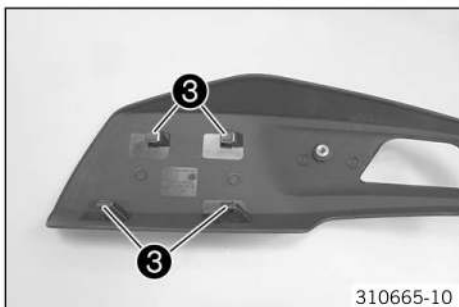

- Grease the absorbing elements 3 slightly to ease assembly.

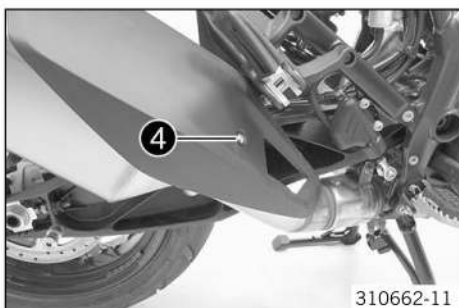

- Position heat protector in the holder from the front.
- Mount and tighten screw 4.

Guideline

Screw, heat guard on main silencer	M5	4 Nm (3 lbf ft)
------------------------------------	----	-----------------

## 10.3 Removing the manifold

### Preparatory work

- Disassemble the main silencer. (p. 60)
- Remove the passenger seat. (p. 72)
- Remove the front rider's seat. (p. 71)
- Remove the crash bar. (p. 32)
- Remove the front side cover. (p. 87)
- Remove the tank cover. (p. 89)
- Remove the mask spoiler. (p. 90)
- Remove the fuel tank. (p. 73)

### Main work

- Remove plug-in connector 1 plug from plug holder and disconnect.
- Remove the cable tie(s) and expose the cable.

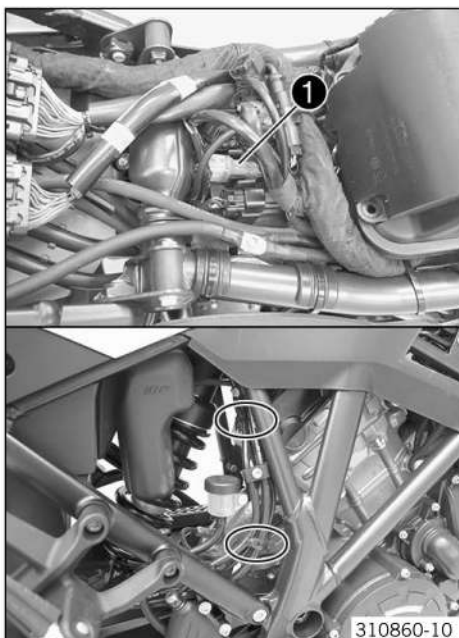

# 10 EXHAUST

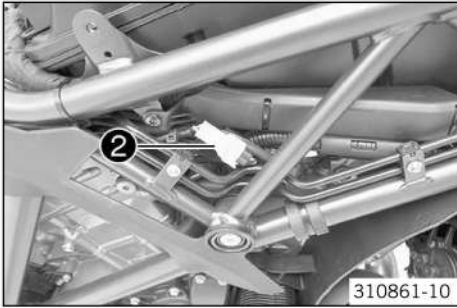

- Disconnect plug-in connector 2.
- Expose the cable.

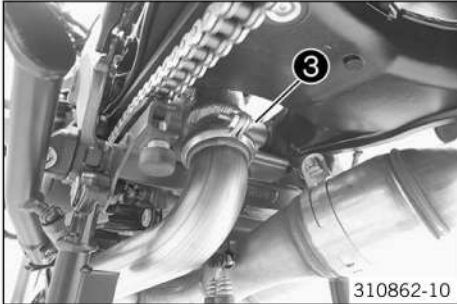

- Remove screw 3.
- Take off the exhaust clamp.

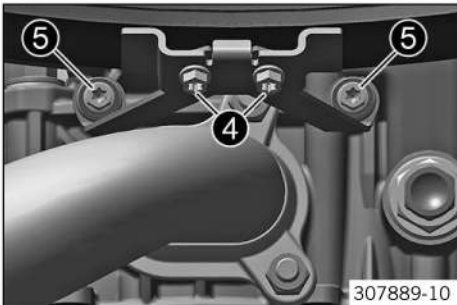

- Remove screws 4.
- Remove screws 5.
- Take off the retaining bracket.

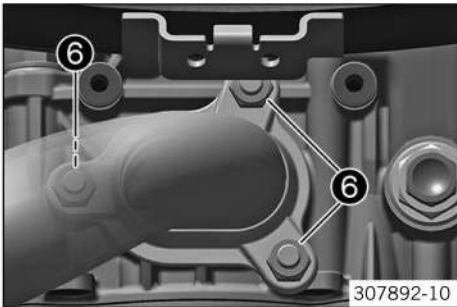

- Remove nuts 6.



- Remove screw 7.



- Lower manifold and remove it in a forward direction.



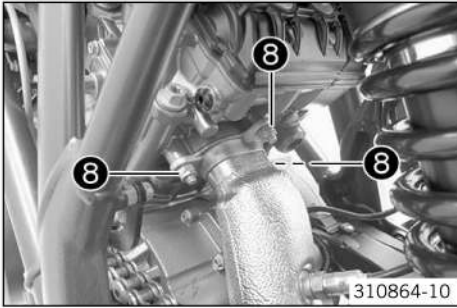

- Remove nuts 8.
- Remove the manifold in a downward direction.

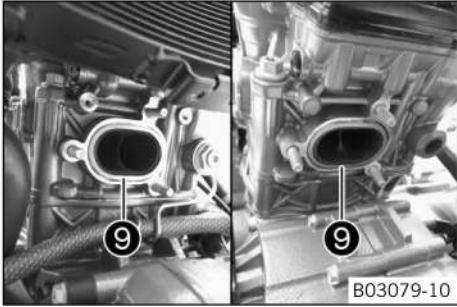

- Remove exhaust gaskets 9.

## 10.4 Installing the manifold

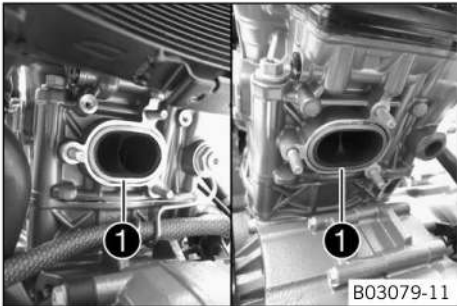

### Main work

- Position exhaust gaskets 1.

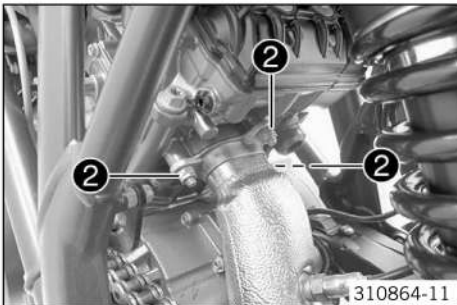

- Position the manifold from below.
- Mount nuts 2 but do not tighten yet.

### Guideline

Nut, manifold on cylinder head	M8	Tightening sequence: Tighten the nuts evenly. Do not bend the metal. 25 Nm (18.4 lbf ft)
--------------------------------	----	---

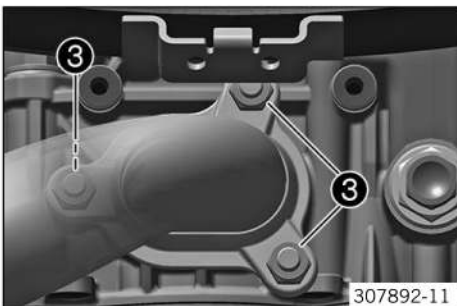

- Position the manifold at the front.
- Mount nuts 3 but do not tighten yet.

### Guideline

Nut, manifold on cylinder head	M8	Tightening sequence: Tighten the nuts evenly. Do not bend the metal. 25 Nm (18.4 lbf ft)
--------------------------------	----	---



- Mount and tighten screw 4.

### Guideline

Screw, exhaust clamp	M8	25 Nm (18.4 lbf ft)
----------------------	----	------------------------

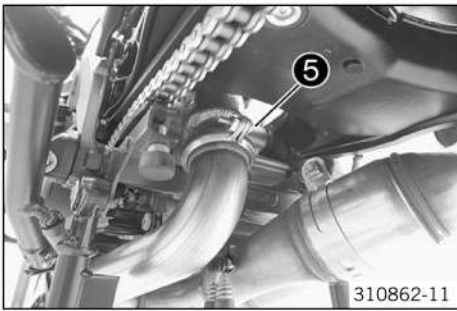

- Position the exhaust clamp.
- Mount and tighten screw **5**.

Guideline

Screw, exhaust clamp	M6	8 Nm (5.9 lbf ft)
----------------------	----	-------------------

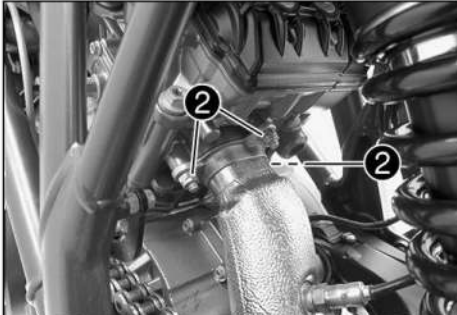

- Tighten nuts **2** and **3**.

Guideline

Nut, manifold on cylinder head	M8	Tightening sequence: Tighten the nuts evenly. Do not bend the metal. 25 Nm (18.4 lbf ft)
--------------------------------	----	---

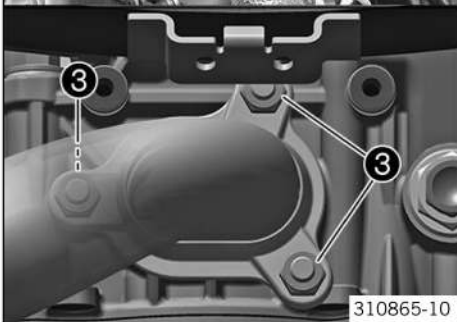

- Route the cable without tension and secure with cable tie(s).
- Join the plug-in connector **6** and position in the plug holder.

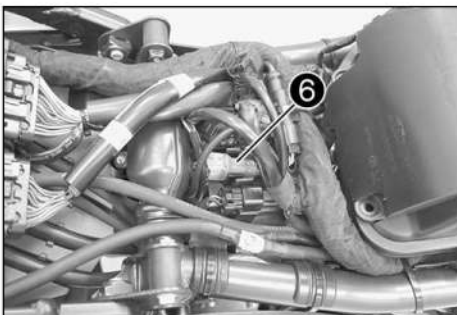

- Route the cable without tension and secure with cable tie(s).
- Join plug-in connector **7**.

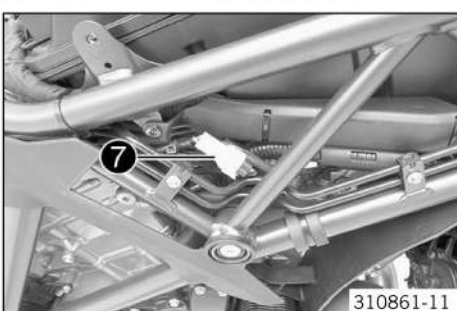

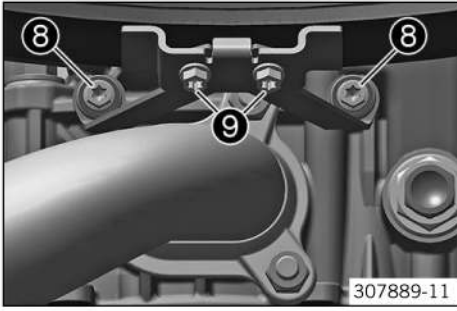

- Position the retaining bracket.
- Mount and tighten screws 8.

Guideline

Screw, cooler retaining bracket	M6	7 Nm (5.2 lbf ft)
---------------------------------	----	-------------------

- Mount and tighten screws 9.

Guideline

Remaining screws, chassis	M5	5 Nm (3.7 lbf ft)
---------------------------	----	-------------------

### Finishing work

- Install the fuel tank. (p. 74)
- Install the mask spoiler. (p. 92)
- Install the tank cover. (p. 89)
- Install the front side cover. (p. 87)
- Install the crash bar. (p. 32)
- Mount the front rider's seat. (p. 71)
- Mount the passenger seat. (p. 72)
- Install the main silencer. (p. 60)

## 11.1 Removing the upper part of the air filter box

### Preparatory work

- Remove the passenger seat. (📖 p. 72)
- Remove the front rider's seat. (📖 p. 71)
- Remove the crash bar. (📖 p. 32)
- Remove the front side cover. (📖 p. 87)
- Remove the tank cover. (📖 p. 89)
- Remove the mask spoiler. (📖 p. 90)
- Remove the fuel tank. (📖 p. 73)

### Main work

- Detach connector ❶.
- Expose cable ❷.

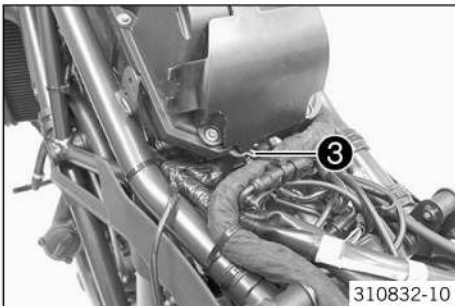
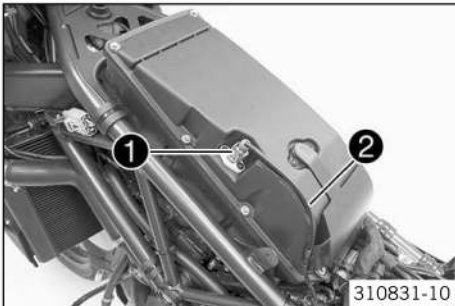

- Push back hose clip ❸.
- Pull off the vent hose.

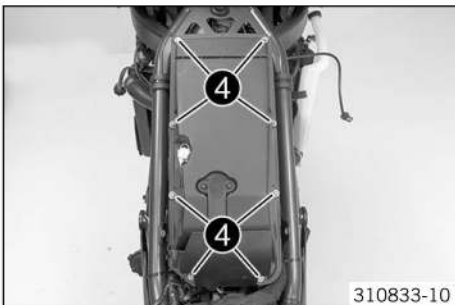

- Remove screws ❹.
- Remove the upper part of the air filter box.

## 11.2 Changing the air filter, cleaning the air filter box

### Preparatory work

- Remove the passenger seat. (📖 p. 72)
- Remove the front rider's seat. (📖 p. 71)
- Remove the crash bar. (📖 p. 32)
- Remove the front side cover. (📖 p. 87)
- Remove the tank cover. (📖 p. 89)
- Remove the mask spoiler. (📖 p. 90)
- Remove the fuel tank. (📖 p. 73)
- Remove the upper part of the air filter box. (📖 p. 66)

### Main work

- Remove air filter clamping wedge ❶ toward the top.

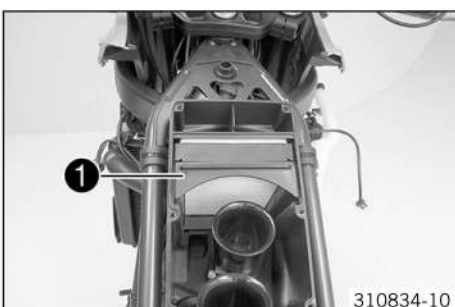

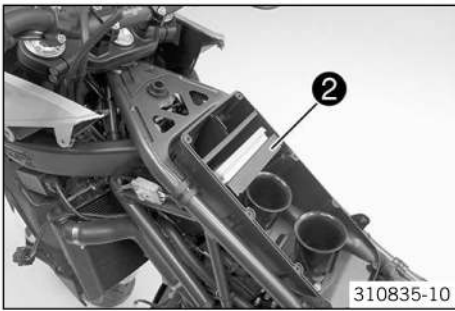

- Remove air filter frame ② with the air filter.

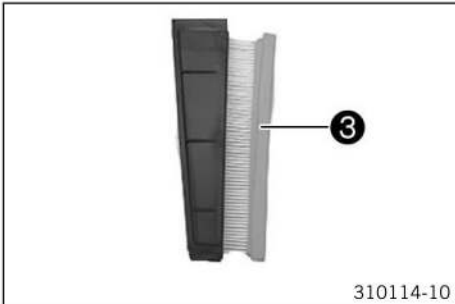

- Clean the air filter box.
- Position the new air filter ③ in the air filter frame.

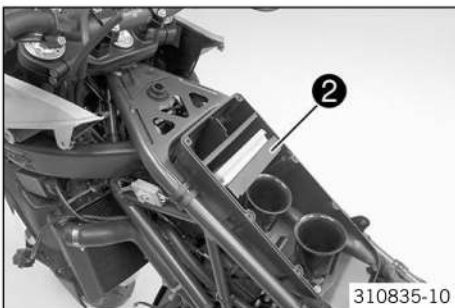

- Position air filter frame ② in the lower section of the air filter box together with the air filter.
  - ✓ The broad side of the air filter frame faces the engine.

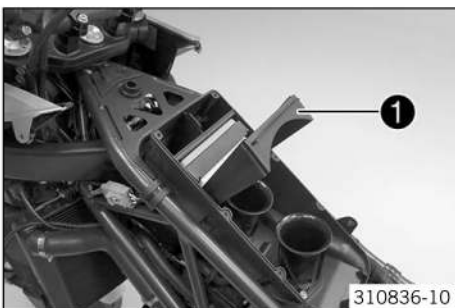

- Mount air filter clamping wedge ①.
  - ✓ The narrow side of the air filter clamping wedge faces the engine.

### Finishing work

- Install the upper part of the air filter box. (p. 67)
- Install the fuel tank. (p. 74)
- Install the mask spoiler. (p. 92)
- Install the tank cover. (p. 89)
- Install the front side cover. (p. 87)
- Install the crash bar. (p. 32)
- Mount the front rider's seat. (p. 71)
- Mount the passenger seat. (p. 72)

## 11.3 Installing the upper part of the air filter box

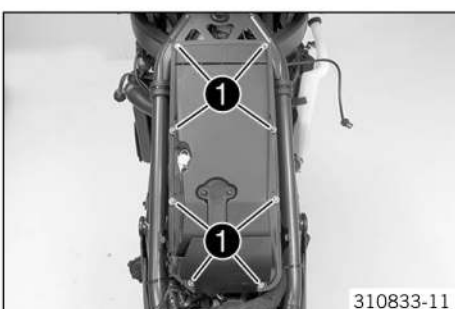

### Main work

- Position the upper part of the air filter box.
- Mount and tighten screws ①.

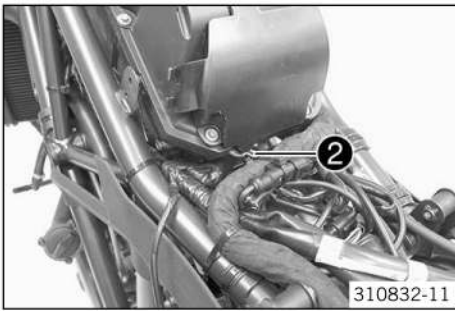

- Mount the vent hose.
- Position hose clip ②.

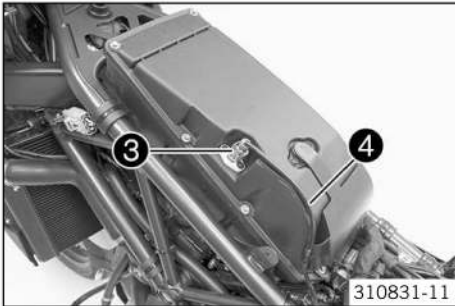

- Plug in connector ③.
- Position cable ④.

**Finishing work**

- Install the fuel tank. (📖 p. 74)
- Install the mask spoiler. (📖 p. 92)
- Install the tank cover. (📖 p. 89)
- Install the front side cover. (📖 p. 87)
- Install the crash bar. (📖 p. 32)
- Mount the front rider's seat. (📖 p. 71)
- Mount the passenger seat. (📖 p. 72)

## 11.4 Removing the lower part of the air filter box

**Preparatory work**

- Remove the passenger seat. (📖 p. 72)
- Remove the front rider's seat. (📖 p. 71)
- Remove the crash bar. (📖 p. 32)
- Remove the front side cover. (📖 p. 87)
- Remove the tank cover. (📖 p. 89)
- Remove the mask spoiler. (📖 p. 90)
- Remove the fuel tank. (📖 p. 73)
- Remove the upper part of the air filter box. (📖 p. 66)

**Main work**

- Remove spring band clamp ①.

Pliers for spring band clamp (60029057100) (📖 p. 347)

- Pull off the vent hose.

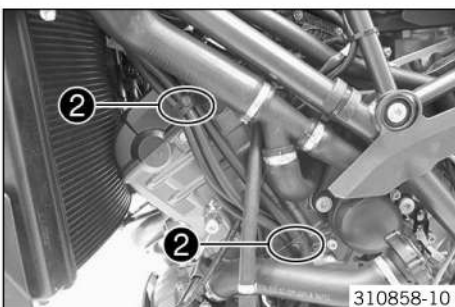

- Remove cable binder ②.

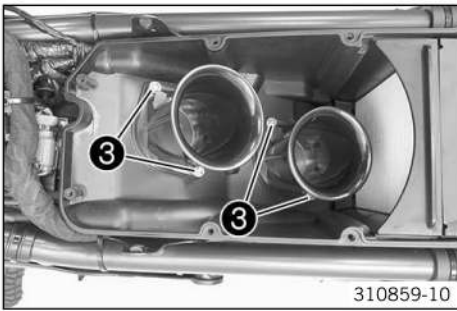

- Remove screws ③.
- Remove the intake trumpet.

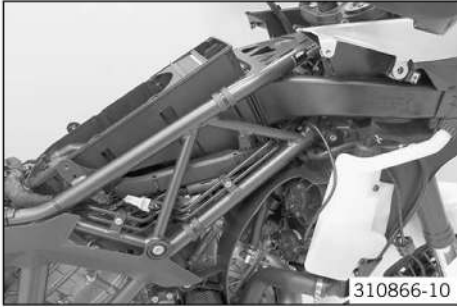

- Raise the lower part of the air filter box and pull it back gently.

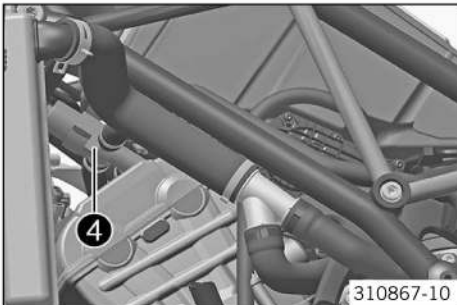

- Remove SLS valve ④ from the holder.

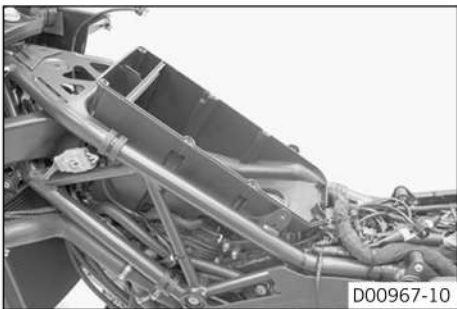

- Remove the lower part of the air filter box.

## 11.5 Installing the lower part of the air filter box

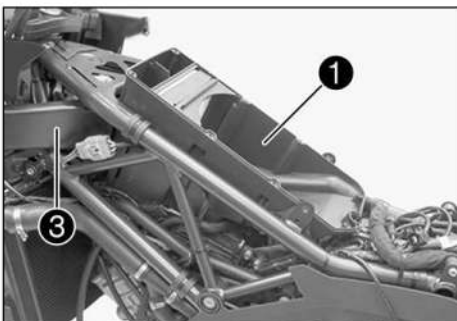

### Main work

- Position the lower part of air filter box ① in the frame.



### Info

Ensure that the O-rings are seated correctly.

- Mount SLS valve ② on holder.
- Position intake ducts ③.



### Info

Ensure that the seals are seated correctly.



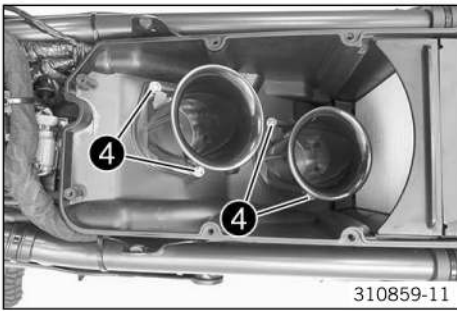

- Position the intake trumpet and mount and tighten screws **4** with bushing.

Guideline

Remaining screws, chassis	M5	5 Nm (3.7 lbf ft)
---------------------------	----	-------------------

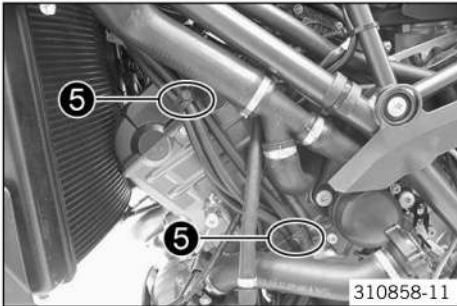

- Route the hose without kinks.
- Mount cable binder **5**.

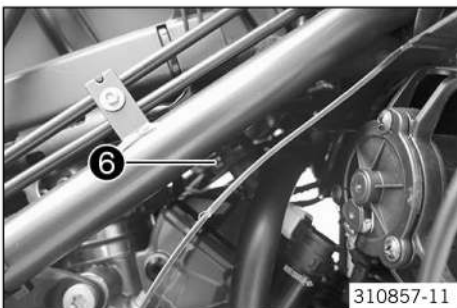

- Mount the vent hose.
- Position spring band clamp **6** with special tool.

Pliers for spring band clamp (60029057100) (p. 347)
---

**Finishing work**

- Install the upper part of the air filter box. (p. 67)
- Install the fuel tank. (p. 74)
- Install the mask spoiler. (p. 92)
- Install the tank cover. (p. 89)
- Install the front side cover. (p. 87)
- Install the crash bar. (p. 32)
- Mount the front rider's seat. (p. 71)
- Mount the passenger seat. (p. 72)



## 12.1 Adjusting the front rider's seat

### Preparatory work

- Remove the passenger seat. (📖 p. 72)

### Lower the front rider's seat:

- Attach the front rider's seat to the fuel tank at the recesses **1**, and push the front rider's seat down and forward at the same time.

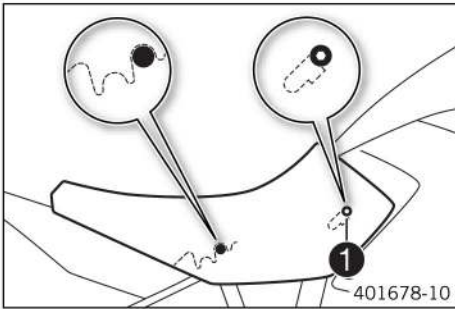

### Raise the front rider's seat:

- Attach the front rider's seat to the fuel tank at the recesses **1**, and push the rider's seat up and forward at the same time.
- Finally, check that the front rider's seat is correctly mounted.

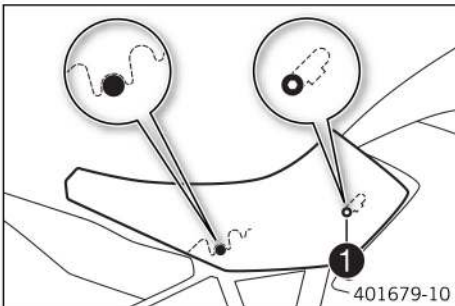

### Finishing work

- Mount the passenger seat. (📖 p. 72)

## 12.2 Removing the front rider's seat

### Preparatory work

- Remove the passenger seat. (📖 p. 72)

### Main work

- Lift the rider's seat back and unhook in the **A** area.



### Info

Pay attention to the seat heating cable.

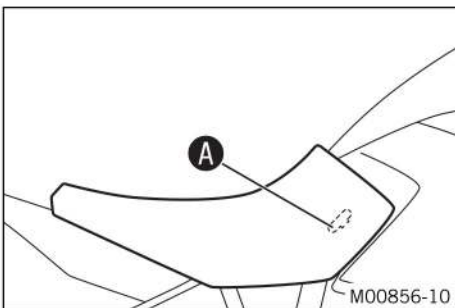

- Disconnect plug-in connector **1**.



## 12.3 Mounting the front rider's seat

### Main work

- Connect plug-in connector **1**.



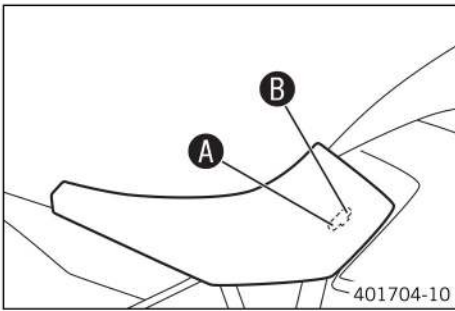

- Attach the recesses on the driver's seat to the fuel tank at the desired seat position **A** or **B**, and push the driver's seat forward while lowering it at the rear.



**Info**  
Ensure that the seat heating cable is correctly routed.

- Finally, check that the driver's seat is correctly mounted.

**Finishing work**

- Mount the passenger seat. (p. 72)

**12.4 Removing the passenger seat**

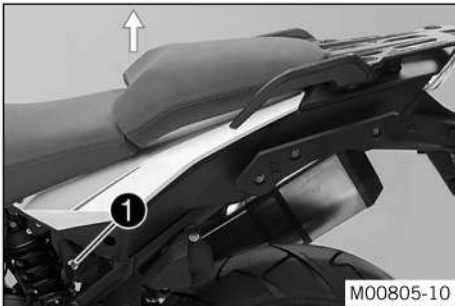

- Insert the ignition key in seat lock **1** and turn it clockwise.
- Raise front of the passenger seat, pull toward the tank, and remove upward.



**Info**  
Pay attention to the seat heating cable.

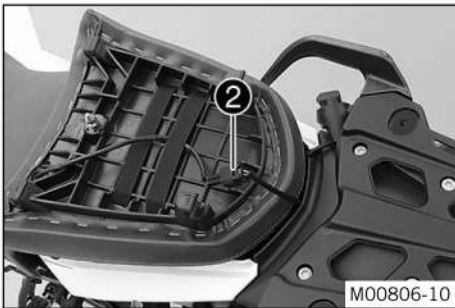

- Disconnect plug-in connector **2**.
- Remove the ignition key.

**12.5 Mounting the passenger seat**

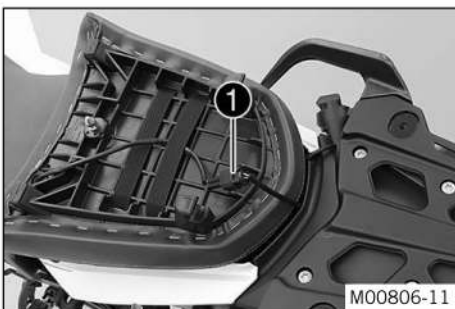

- Connect plug-in connector **1**.



**Info**  
Ensure that the seat heating cable is correctly routed.

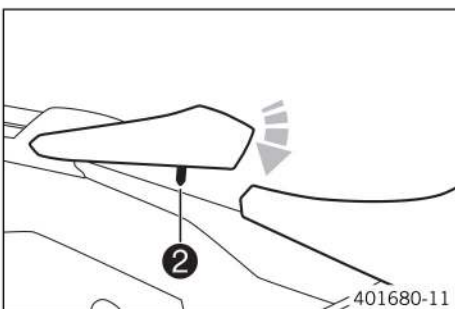

- Attach the hooks on the passenger seat to the hanger on the subframe.
- Lower passenger seat and push back at the same time.
- Position locking pin **2** in lock housing and press passenger seat forward until the locking pin engages with an audible click.
- Check that the passenger seat is correctly mounted.

## 12.6 Removing the fuel tank

**Danger**  
**Fire hazard** Fuel is highly flammable.

The fuel in the fuel tank expands when warm and can escape if overfilled.

- Do not refuel the vehicle in the vicinity of open flames or lit cigarettes.
- Switch off the engine for refueling.
- Make sure that no fuel is spilled; particularly not on hot parts of the vehicle.
- If any fuel is spilled, wipe it off immediately.
- Observe the specifications for refueling.

**Warning**  
**Danger of poisoning** Fuel is poisonous and a health hazard.

- Avoid skin, eye and clothing contact with fuel.
- Immediately consult a doctor if you swallow fuel.
- Do not inhale fuel vapors.
- In case of skin contact, rinse the affected area with plenty of water.
- Rinse the eyes thoroughly with water, and consult a doctor in case of fuel contact with the eyes.
- Change your clothing in case of fuel spills on them.
- Keep fuels correctly in a suitable canister, and out of the reach of children.

### Preparatory work

- Remove the passenger seat. (📖 p. 72)
- Remove the front rider's seat. (📖 p. 71)
- Remove the crash bar. (📖 p. 32)
- Remove the front side cover. (📖 p. 87)
- Remove the tank cover. (📖 p. 89)
- Remove the mask spoiler. (📖 p. 90)

### Main work

- Close fuel cocks **1**.

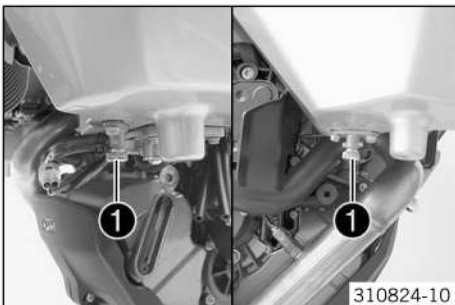

310824-10

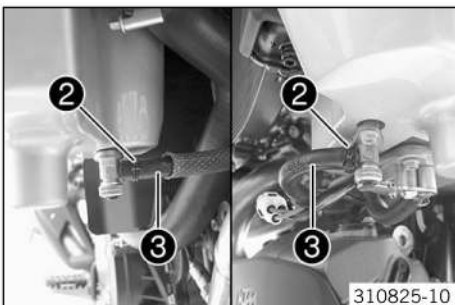

310825-10

- Push back hose clips **2** and remove fuel hose **3**.

**i Info**

Remaining fuel may flow out of the fuel hose.

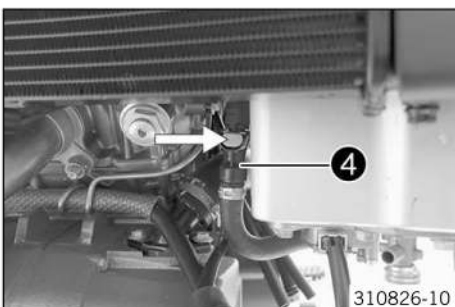

310826-10

- Thoroughly clean the plug-in connection of the fuel line using compressed air.

**i Info**

Under no circumstances should dirt enter into the fuel line. Dirt in the fuel line clogs the injection valve!

- Press on the small metal plate and disconnect fuel hose connection **4**.

**i Info**

Remaining fuel may flow out of the fuel hose.

- Assemble the wash cap set.

Wash cap set (81212016000)

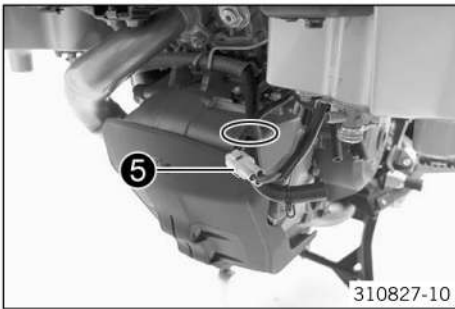

- Remove the cable tie(s).
- Disconnect plug-in connector 5.

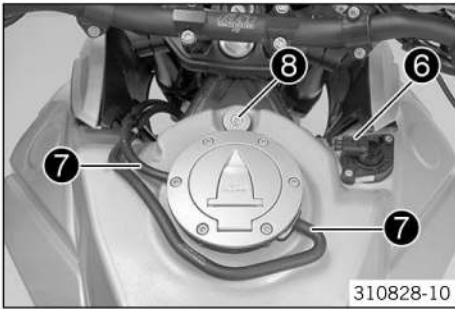

- Unplug connector 6.
- Detach vent hose 7.
- Remove screw 8 with bearing sleeve and rubber bushings.

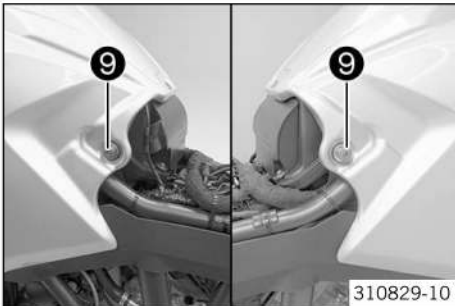

- Remove screws 9.



- Take off the fuel tank.

**i Info**  
Pay attention to the inside cover.

## 12.7 Installing the fuel tank

**! Danger**  
**Fire hazard** Fuel is highly flammable.

The fuel in the fuel tank expands when warm and can escape if overfilled.

- Do not refuel the vehicle in the vicinity of open flames or lit cigarettes.
- Switch off the engine for refueling.
- Make sure that no fuel is spilled; particularly not on hot parts of the vehicle.
- If any fuel is spilled, wipe it off immediately.
- Observe the specifications for refueling.



**Warning**

**Danger of poisoning** Fuel is poisonous and a health hazard.

- Avoid skin, eye and clothing contact with fuel.
- Immediately consult a doctor if you swallow fuel.
- Do not inhale fuel vapors.
- In case of skin contact, rinse the affected area with plenty of water.
- Rinse the eyes thoroughly with water, and consult a doctor in case of fuel contact with the eyes.
- Change your clothing in case of fuel spills on them.
- Keep fuels correctly in a suitable canister, and out of the reach of children.

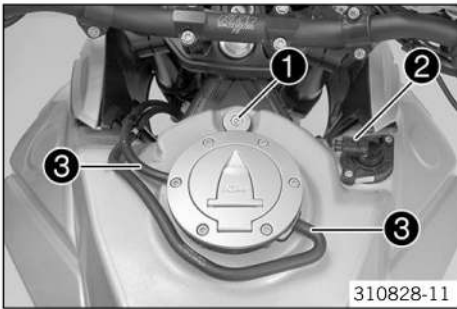

**Main work**

- Position the fuel tank.
- Mount and tighten screw **1** with bearing sleeve and rubber bushings.

Guideline

Screw, fuel tank	M8	15 Nm (11.1 lbf ft)
------------------	----	------------------------

- Plug in connector **2**.
- Mount vent hoses **3**.

- Mount screws **4** with bushings and tighten.

Guideline

Screw, fuel tank	M6	10 Nm (7.4 lbf ft)
------------------	----	--------------------

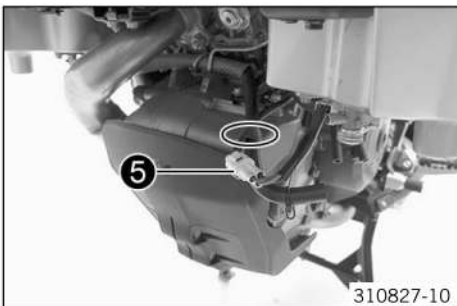
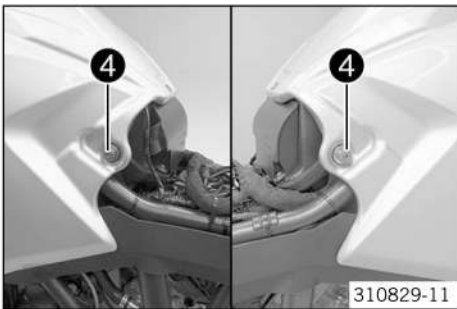

- Join plug-in connector **5**.
- Mount the cable tie(s).

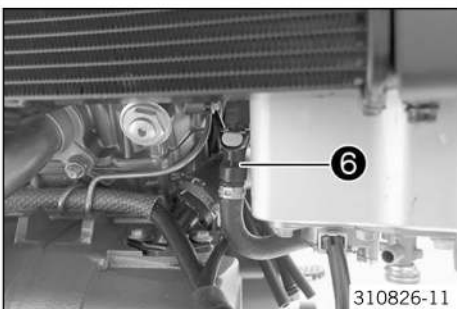

- Remove the wash cap set.
- Thoroughly clean the plug-in connection of the fuel line using compressed air.



**Info**

Under no circumstances should dirt enter into the fuel line. Dirt in the fuel line clogs the injection valve!

- Join fuel hose connection **6**.

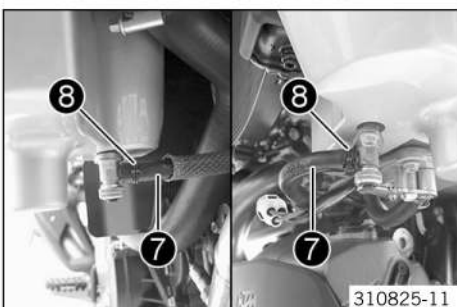

- Mount fuel hose **7**.
- Position hose clips **8**.

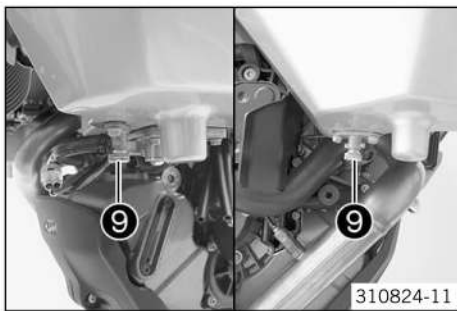

- Open fuel cocks ⑨.

### Finishing work

- Install the mask spoiler. (📖 p. 92)
- Install the tank cover. (📖 p. 89)
- Install the front side cover. (📖 p. 87)
- Install the crash bar. (📖 p. 32)
- Mount the front rider's seat. (📖 p. 71)
- Mount the passenger seat. (📖 p. 72)

## 12.8 Checking the fuel pressure



### Danger

**Fire hazard** Fuel is highly flammable.

The fuel in the fuel tank expands when warm and can escape if overfilled.

- Do not refuel the vehicle in the vicinity of open flames or lit cigarettes.
- Switch off the engine for refueling.
- Make sure that no fuel is spilled; particularly not on hot parts of the vehicle.
- If any fuel is spilled, wipe it off immediately.
- Observe the specifications for refueling.



### Warning

**Danger of poisoning** Fuel is poisonous and a health hazard.

- Avoid skin, eye and clothing contact with fuel.
- Immediately consult a doctor if you swallow fuel.
- Do not inhale fuel vapors.
- In case of skin contact, rinse the affected area with plenty of water.
- Rinse the eyes thoroughly with water, and consult a doctor in case of fuel contact with the eyes.
- Change your clothing in case of fuel spills on them.
- Keep fuels correctly in a suitable canister, and out of the reach of children.

### Condition

The fuel tank is full.

Ensure that the battery voltage does not drop below 12.5 V.

The ignition is off.

The diagnostic tool is connected.

- Press down the metal plate and disconnect the fuel hose connection ①.



### Info

Remaining fuel may flow out of the fuel hose.

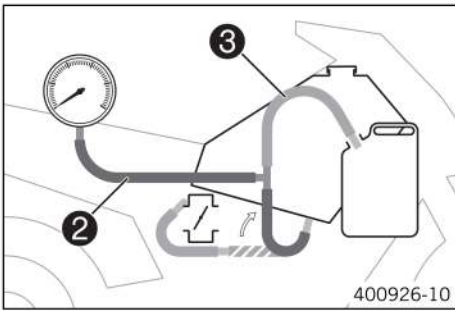

- Mount special tool **2**.

Pressure tester (61029094000) (📖 p. 348)

- Mount special tool **3** with nozzle code **1,05**.

Testing hose (61029093000) (📖 p. 347)

- Position the hose end in a fuel can.

Guideline

Minimum size of fuel can	10 l (2.6 US gal)
--------------------------	-------------------

- Connect the diagnostic tool and start it.
- Perform the **"Engine Electronics" > "Actuator Test" > "Function test of fuel pump control"**.
- Check the fuel pressure with the filler cap closed.

Fuel pressure

When the fuel pump is active	3.8... 4.2 bar (55... 61 psi)
------------------------------	-------------------------------

- » If the specification is not reached:
  - Open the filler cap.
  - Check the tank air vent system.

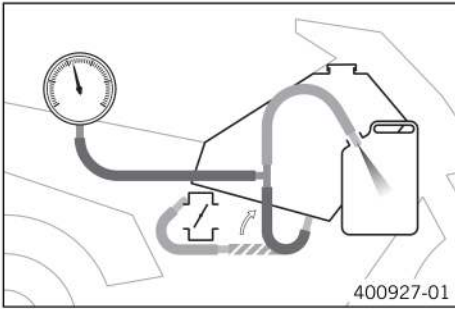

- Check the fuel pressure with the filler cap open.

Fuel pressure

When the fuel pump is active	3.8... 4.2 bar (55... 61 psi)
------------------------------	-------------------------------

- » If the specification is not reached:
  - Check that the fuel line is clear.
  - Change the fuel filter. (📖 p. 80)
  - Change the fuel pump. (📖 p. 77)

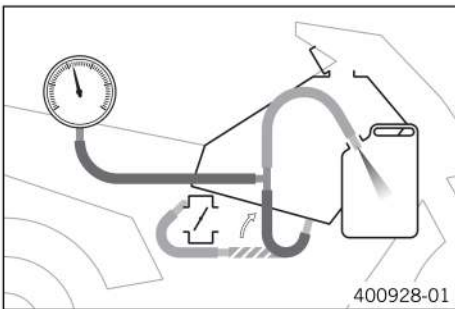

- Finish the actuator test.
- Remove the special tools.
- Thoroughly clean the plug-in connection of the fuel line using compressed air.

**i Info**

Under no circumstances should dirt enter into the fuel line. Dirt in the fuel line clogs the injection valve.

- Join fuel hose connection **1**.



## 12.9 Changing the fuel pump



**Danger**

**Fire hazard** Fuel is highly flammable.

The fuel in the fuel tank expands when warm and can escape if overfilled.

- Do not refuel the vehicle in the vicinity of open flames or lit cigarettes.
- Switch off the engine for refueling.
- Make sure that no fuel is spilled; particularly not on hot parts of the vehicle.
- If any fuel is spilled, wipe it off immediately.
- Observe the specifications for refueling.



**Warning**

**Danger of poisoning** Fuel is poisonous and a health hazard.

- Avoid skin, eye and clothing contact with fuel.
- Immediately consult a doctor if you swallow fuel.
- Do not inhale fuel vapors.
- In case of skin contact, rinse the affected area with plenty of water.
- Rinse the eyes thoroughly with water, and consult a doctor in case of fuel contact with the eyes.
- Change your clothing in case of fuel spills on them.
- Keep fuels correctly in a suitable canister, and out of the reach of children.

**Preparatory work**

- Drain the fuel from the fuel tank into a suitable container.

**Main work**

- Remove screw connections ❶.

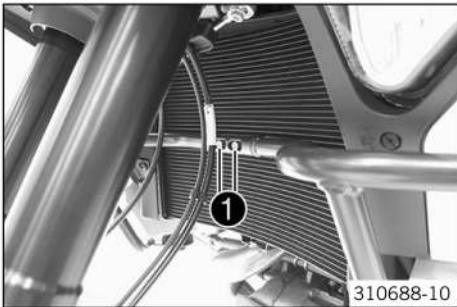

- Remove screws ❷ and take off the clamp halves.

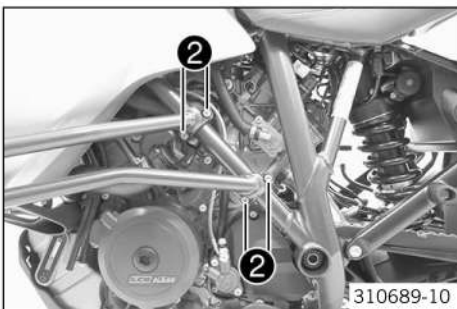

- Remove screw ❸.
- Take off the left crash bar.

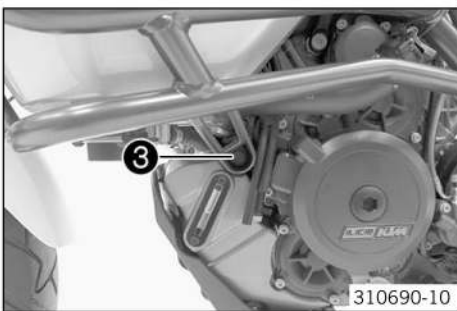

- Thoroughly clean the plug-in connection of the fuel line using compressed air.



**Info**

Under no circumstances should dirt enter into the fuel line. Dirt in the fuel line clogs the injection valve.

- Press on the small metal plate and disconnect fuel hose connection ❹.



**Info**

Remaining fuel may flow out of the fuel hose.

- Assemble the wash cap set.

Wash cap set (81212016000)

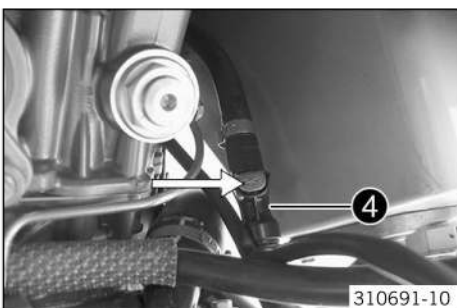



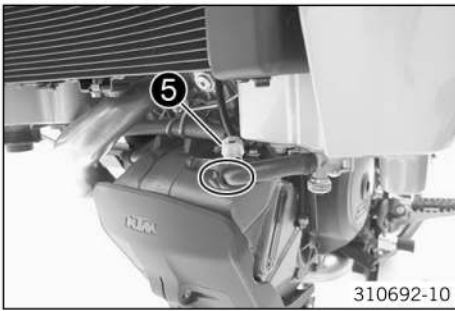

- Remove the cable tie(s).
- Disconnect plug-in connector 5.

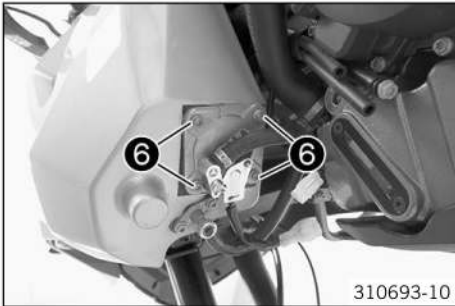

- Remove screws 6.
- Pull out the fuel pump.

**i Info**

Remaining fuel may flow out of the fuel tank. Place a suitable container under the engine.

- Position the new fuel pump with O-ring in the fuel tank.
- Mount and tighten screws 6.

Guideline

Screw, fuel pump	M6	6 Nm (4.4 lbf ft)
------------------	----	-------------------

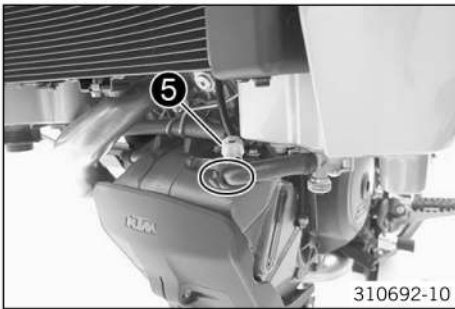

- Connect plug-in connector 5.
- Secure the cable with the cable binders.

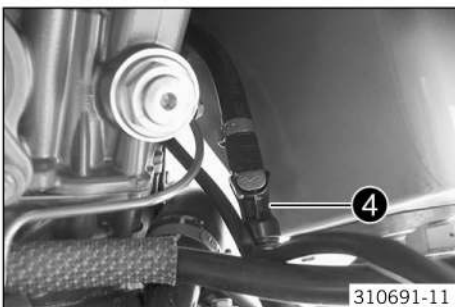

- Remove the wash cap set.
- Thoroughly clean the plug-in connection of the fuel line using compressed air.

**i Info**

Under no circumstances should dirt enter into the fuel line. Dirt in the fuel line clogs the injection valve.

- Join fuel hose connection 4.



- Position the left crash bar with the frame protector.
- ✓ The fuel tank support ring should be correctly positioned on the fuel tank.

**i Info**

Cover the components to protect them against damage.

- Mount screw 3 but do not tighten yet.

Guideline

Remaining chassis screws	M8	25 Nm (18.4 lbf ft)
--------------------------	----	---------------------

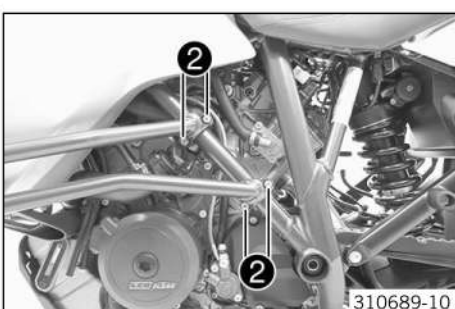

- Position the clamp halves.
- Mount screws 2, but do not tighten yet.

Guideline

Remaining chassis screws	M6	10 Nm (7.4 lbf ft)
--------------------------	----	--------------------

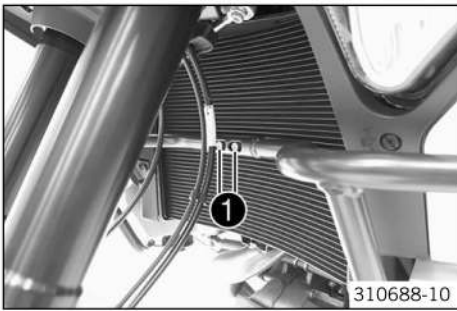

- Mount and tighten fittings **1**.

Guideline

Remaining chassis screws	M6	10 Nm (7.4 lbf ft)
--------------------------	----	--------------------

- ✓ The crash bars are aligned with each other.

- Tighten screws **2**.

Guideline

Remaining chassis screws	M6	10 Nm (7.4 lbf ft)
--------------------------	----	--------------------

- Tighten screw **3**.

Guideline

Remaining chassis screws	M8	25 Nm (18.4 lbf ft)
--------------------------	----	------------------------

## 12.10 Changing the fuel filter



### Danger

**Fire hazard** Fuel is highly flammable.

The fuel in the fuel tank expands when warm and can escape if overfilled.

- Do not refuel the vehicle in the vicinity of open flames or lit cigarettes.
- Switch off the engine for refueling.
- Make sure that no fuel is spilled; particularly not on hot parts of the vehicle.
- If any fuel is spilled, wipe it off immediately.
- Observe the specifications for refueling.



### Warning

**Danger of poisoning** Fuel is poisonous and a health hazard.

- Avoid skin, eye and clothing contact with fuel.
- Immediately consult a doctor if you swallow fuel.
- Do not inhale fuel vapors.
- In case of skin contact, rinse the affected area with plenty of water.
- Rinse the eyes thoroughly with water, and consult a doctor in case of fuel contact with the eyes.
- Change your clothing in case of fuel spills on them.
- Keep fuels correctly in a suitable canister, and out of the reach of children.

### Preparatory work

- Drain the fuel from the fuel tank into a suitable container.

### Main work

- Remove screw connections **1**.

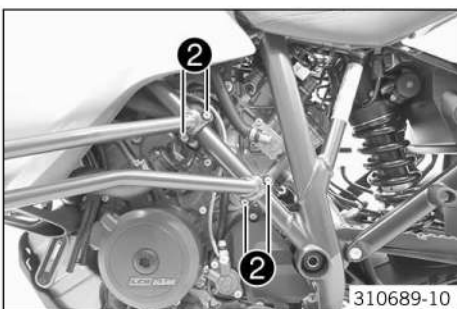
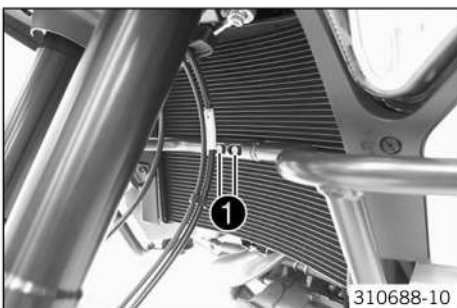

- Remove screws **2** and take off the clamp halves.

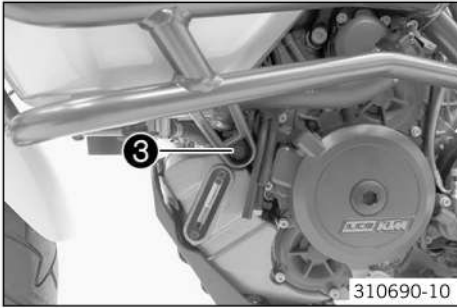

- Remove screw 3.
- Take off the left crash bar.

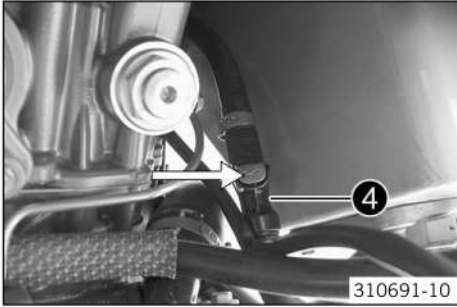

- Thoroughly clean the plug-in connection of the fuel line using compressed air.



**Info**

Under no circumstances should dirt enter into the fuel line. Dirt in the fuel line clogs the injection valve.

- Press on the small metal plate and disconnect fuel hose connection 4.



**Info**

Remaining fuel may flow out of the fuel hose.

- Assemble the wash cap set.

Wash cap set (81212016000)

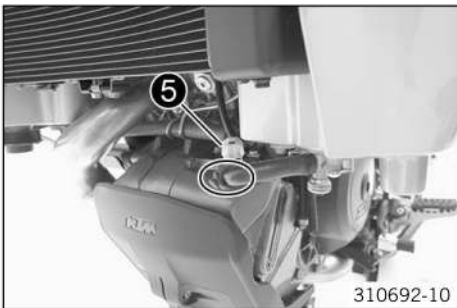

- Remove the cable tie(s).
- Disconnect plug-in connector 5.

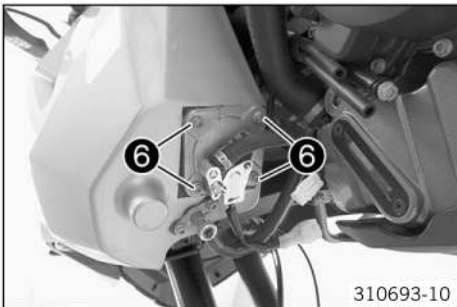

- Remove screws 6.
- Pull out the fuel pump.



**Info**

Remaining fuel may flow out of the fuel tank. Place a suitable container under the engine.

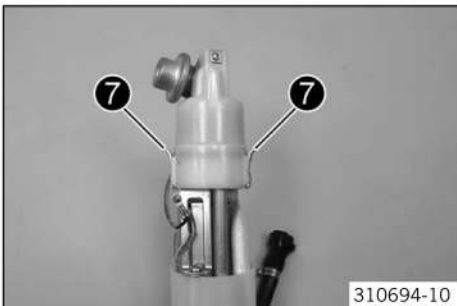

- Push clamps 7 outward.
- Take off the fuel filter housing.

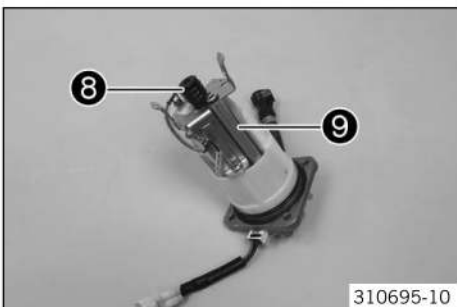

- Remove gasket 8.
- Take off fuel pipe 9.

## 12 FUEL TANK, SEAT, TRIM

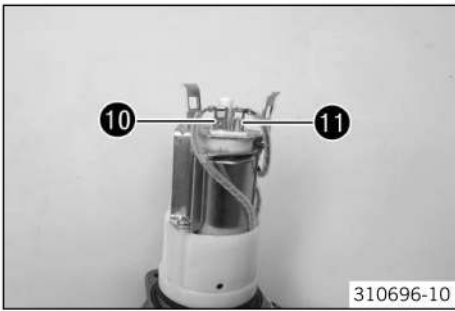

- Detach connectors **10** and **11**.

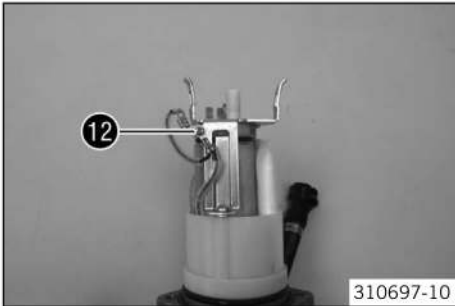

- Remove screw **12** with the washer.

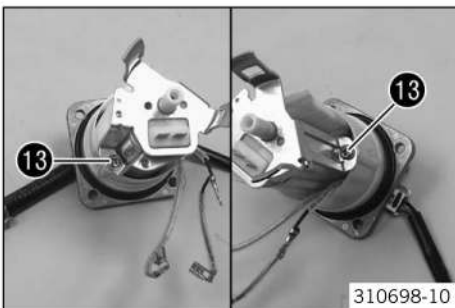

- Remove screws **13**.

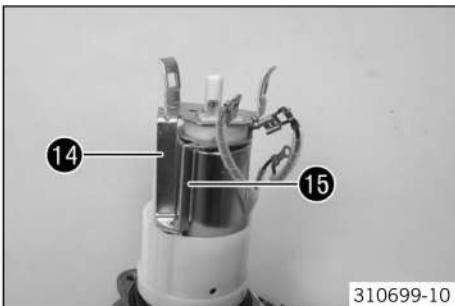

- Remove retaining brackets **14** and **15**.

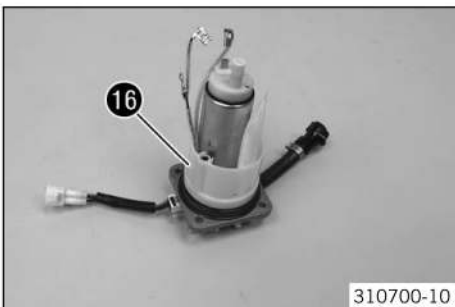

- Remove plastic housing **16** with the distance sleeves.



- Take the fuel pump out of the fuel pump cover.

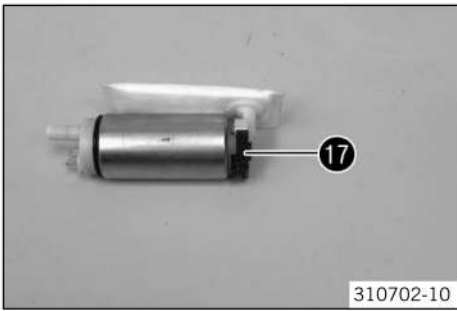

- Take off sealing element **17**.



- Remove the fuel filter.
- Mount the new fuel filter.

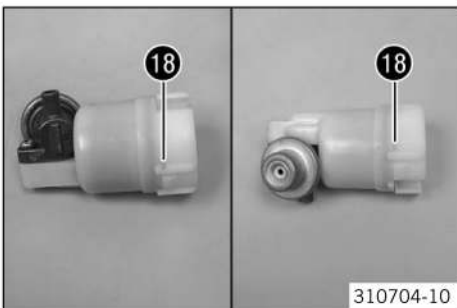

- Release latch **18**.
- Pull off the outer fuel filter housing.

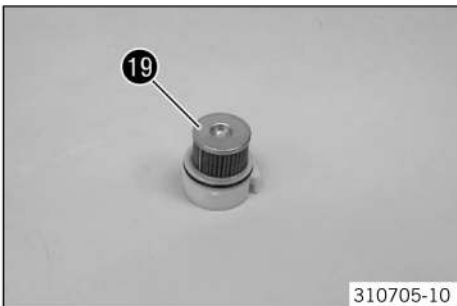

- Take off fuel filter **19**.
- Mount the new fuel filter.

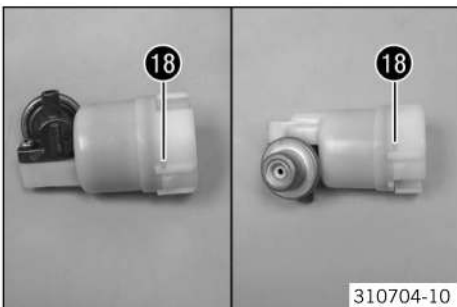

- Mount the outer fuel filter housing.
- ✓ Locking mechanism **18** engages in the fuel filter housing.

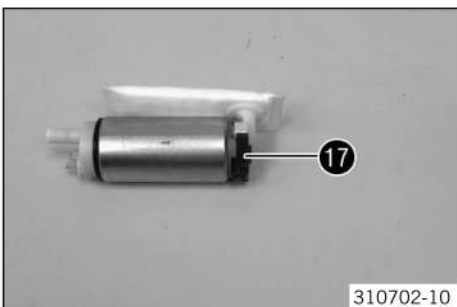

- Mount sealing element **17**.
- Position the fuel pump in the fuel pump cover.

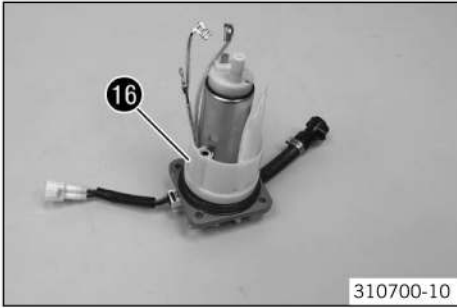

- Mount plastic housing 16 with the distance sleeves.  
✓ The lugs of the plastic housing engage in the holes of the fuel pump cover.

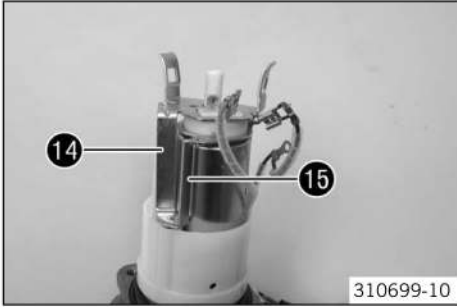

- Mount retaining brackets 14 and 15.

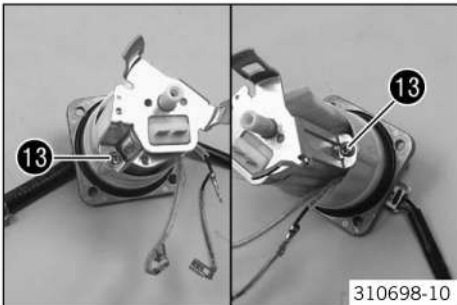

- Mount and tighten screws 13.



- Mount and tighten screw 12 with the washer.



- Plug in connectors 10 and 11.

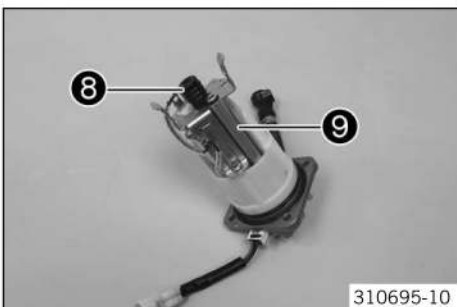

- Mount fuel pipe 9.
- Mount gasket 8.

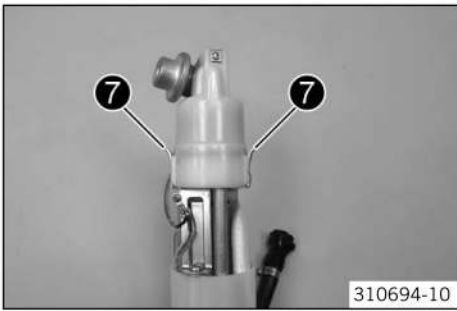

- Mount the fuel filter housing.
- ✓ Clamps **7** must engage.

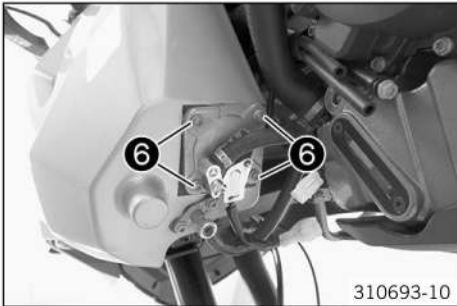

- Position the fuel pump with O-ring in the fuel tank.
- Mount and tighten screws **6**.

Guideline

Screw, fuel pump	M6	6 Nm (4.4 lbf ft)
------------------	----	-------------------



- Connect plug-in connector **5**.
- Secure the cable with the cable binders.



- Remove the wash cap set.
- Thoroughly clean the plug-in connection of the fuel line using compressed air.

**i** Info

Under no circumstances should dirt enter into the fuel line. Dirt in the fuel line clogs the injection valve.

- Join fuel hose connection **4**.



- Position the left crash bar with the frame protector.
- ✓ The fuel tank support ring should be correctly positioned on the fuel tank.

**i** Info

Cover the components to protect them against damage.

- Mount screw **3** but do not tighten yet.

Guideline

Remaining chassis screws	M8	25 Nm (18.4 lbf ft)
--------------------------	----	---------------------

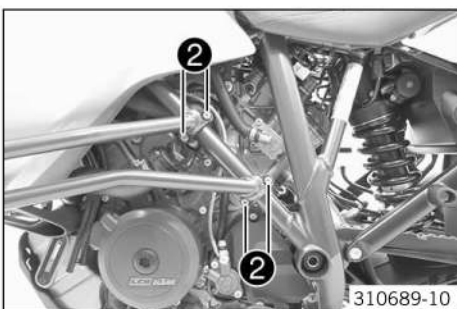

- Position the clamp halves.
- Mount screws **2**, but do not tighten yet.

Guideline

Remaining chassis screws	M6	10 Nm (7.4 lbf ft)
--------------------------	----	--------------------

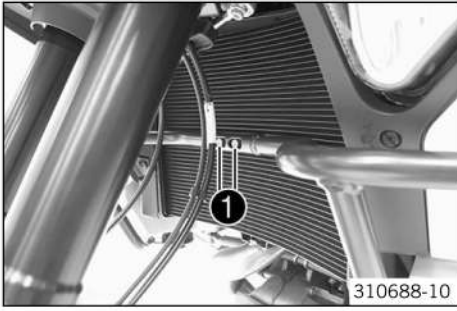

- Mount and tighten fittings **1**.

Guideline

Remaining chassis screws	M6	10 Nm (7.4 lbf ft)
--------------------------	----	--------------------

- ✓ The crash bars are aligned with each other.

- Tighten screws **2**.

Guideline

Remaining chassis screws	M6	10 Nm (7.4 lbf ft)
--------------------------	----	--------------------

- Tighten screw **3**.

Guideline

Remaining chassis screws	M8	25 Nm (18.4 lbf ft)
--------------------------	----	------------------------



## 13.1 Removing the front side cover

### Preparatory work

- Remove the crash bar. (📖 p. 32)

### Main work

- Remove screw ❶.

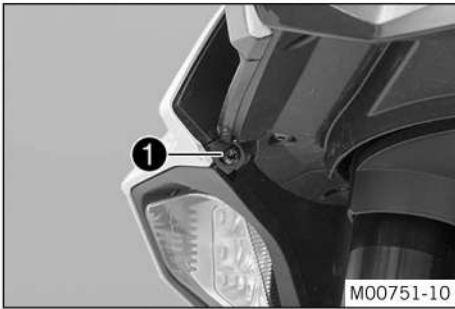

- Remove screw ❷.

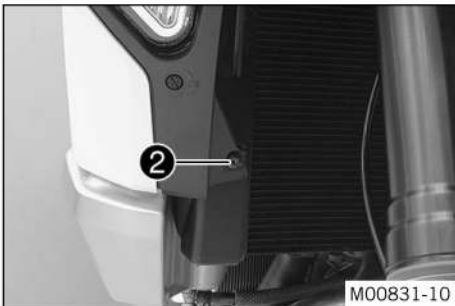

- Remove screws ❸.
- Remove side cover ❹.



### **i** Info

Pay attention to the cornering light cable.

- Unplug connector ❺.
- Repeat the operation on the opposite side.



## 13.2 Installing the front side cover

### Main work

- Plug in connector ❶.



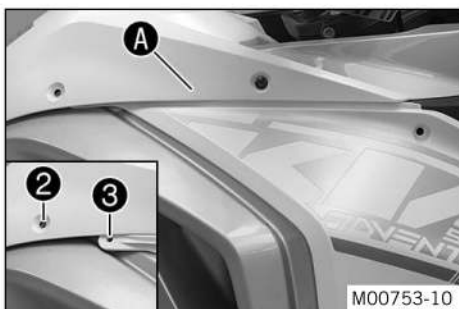

- Position the side cover in the **A** area under the tank cover.  
 ✓ The holes **2** and **3** are adjacent to each other.

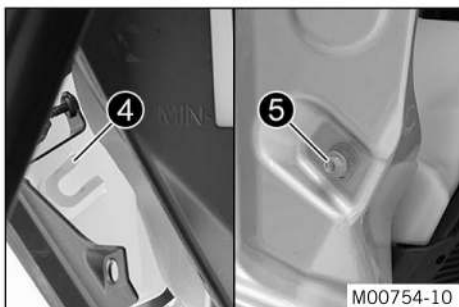

- Attach catch **4** of the side cover to bracket **5** and position on the fuel tank.

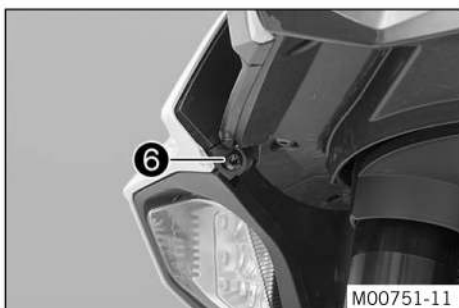

- Mount and tighten screw **6**.

Guideline

Screw, cover part	M5	3.5 Nm (2.58 lbf ft)
-------------------	----	-------------------------

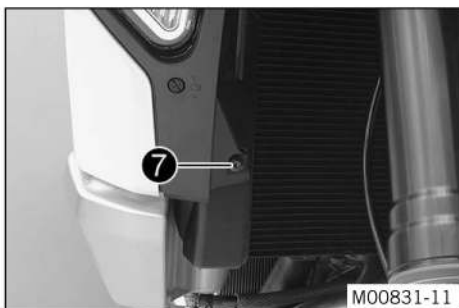

- Mount and tighten screw **7**.

Guideline

Screw, cover part	M5	3.5 Nm (2.58 lbf ft)
-------------------	----	-------------------------



- Mount and tighten screws **8**.

Guideline

Screw, cover part	M5	3.5 Nm (2.58 lbf ft)
-------------------	----	-------------------------

- Repeat the operation on the opposite side.

### Finishing work

- Install the crash bar. (📖 p. 32)

## 13.3 Removing the tank cover

### Preparatory work

- Remove the passenger seat. (📖 p. 72)
- Remove the front rider's seat. (📖 p. 71)
- Remove the crash bar. (📖 p. 32)
- Remove the front side cover. (📖 p. 87)

### Main work

- Remove screw ❶.
- Remove screw ❷.

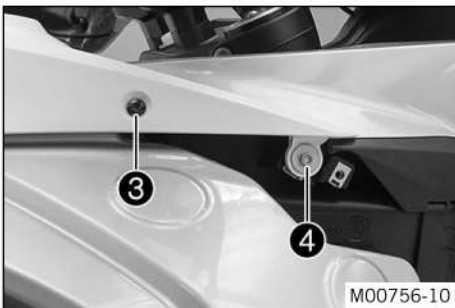
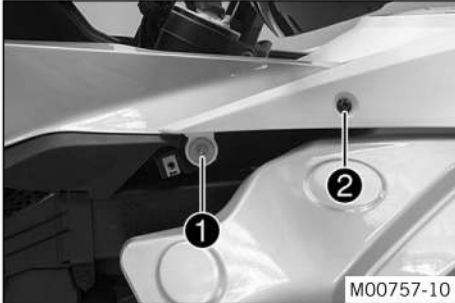

- Remove screw ❸.
- Remove screw ❹.

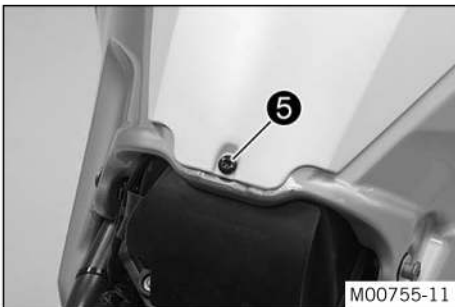

- Remove screw ❺.



- Raise the tank cover at the rear and remove it in a forward direction.

## 13.4 Installing the tank cover

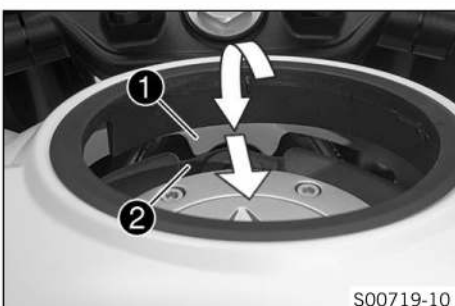

### Main work

- Position the tank cover.
- ✓ Catch ❶ engages under the tank ❷.

### Info

Pay attention to the sealing lip and the bleeder hose.



- Mount and tighten screw ③.

Guideline

Screw, cover part	M5	3.5 Nm (2.58 lbf ft)
-------------------	----	-------------------------

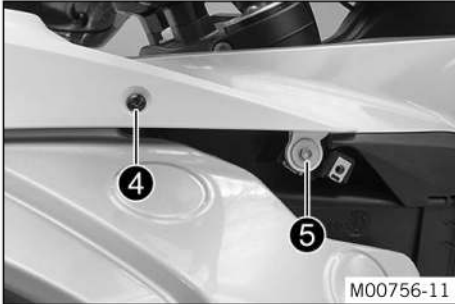

- Mount and tighten screw ④.

Guideline

Screw, cover part	M5	3.5 Nm (2.58 lbf ft)
-------------------	----	-------------------------

- Mount and tighten screw ⑤.

Guideline

Screw, cover part	M6	6 Nm (4.4 lbf ft)
-------------------	----	-------------------

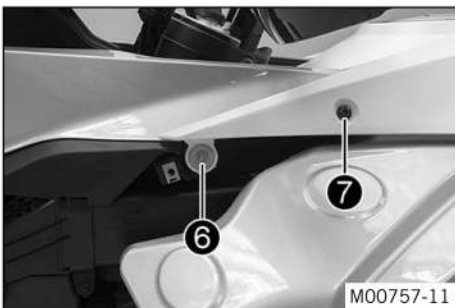

- Mount and tighten screw ⑥.

Guideline

Screw, cover part	M6	6 Nm (4.4 lbf ft)
-------------------	----	-------------------

- Mount and tighten screw ⑦.

Guideline

Screw, cover part	M5	3.5 Nm (2.58 lbf ft)
-------------------	----	-------------------------

**Finishing work**

- Install the front side cover. (📖 p. 87)
- Install the crash bar. (📖 p. 32)
- Mount the front rider's seat. (📖 p. 71)
- Mount the passenger seat. (📖 p. 72)

**13.5 Removing the mask spoiler**

**Preparatory work**

- Remove the passenger seat. (📖 p. 72)
- Remove the front rider's seat. (📖 p. 71)
- Remove the crash bar. (📖 p. 32)
- Remove the front side cover. (📖 p. 87)
- Remove the tank cover. (📖 p. 89)

**Main work**

- Remove screw ①.



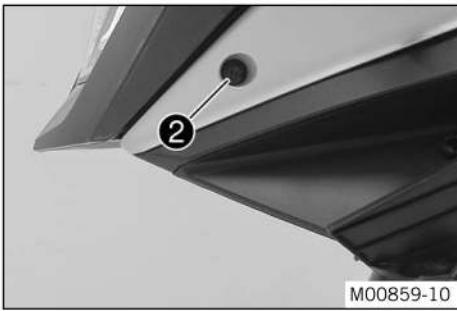

- Remove screw ②.

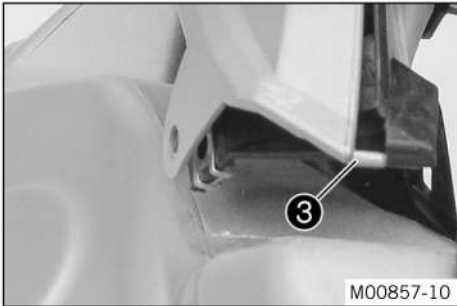

- Loosen holding lug ③ from the inside cover.

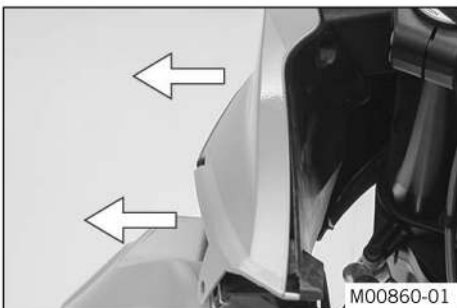

- Remove the mask spoiler laterally from the supports.

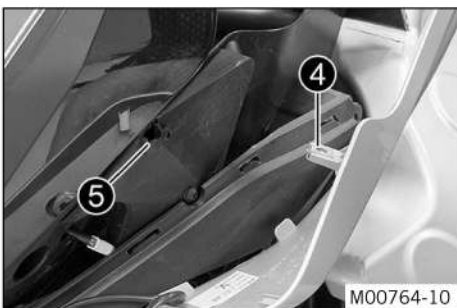

- Remove catch ④ upward from the bracket ⑤.

**i Info**

Pay attention to the turn signal cable.



**(Super Adventure EU/FR/AU/JP)**

- Disconnect plug-in connector ⑥.
- Remove the mask spoiler with the turn signal.
- Repeat these steps on the opposite side.

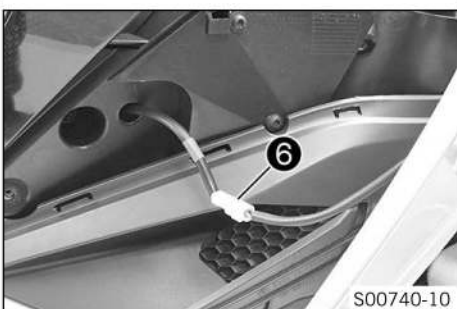

**(Super Adventure US/CN)**

- Disconnect plug-in connector ⑥.
- Remove the mask spoiler with the turn signal.
- Repeat these steps on the opposite side.

## 13.6 Installing the mask spoiler

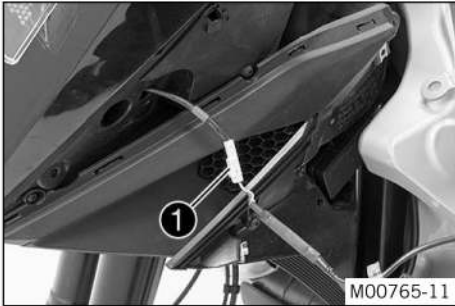

### Main work

(Super Adventure EU/FR/AU/JP)

- Connect plug-in connector 1.

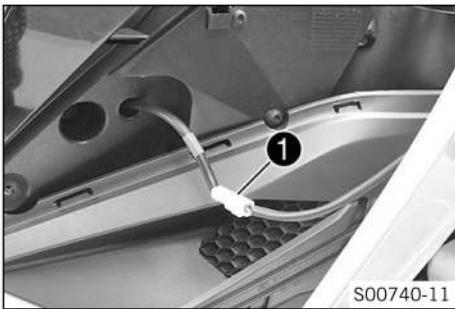

(Super Adventure US/CN)

- Connect plug-in connector 1.

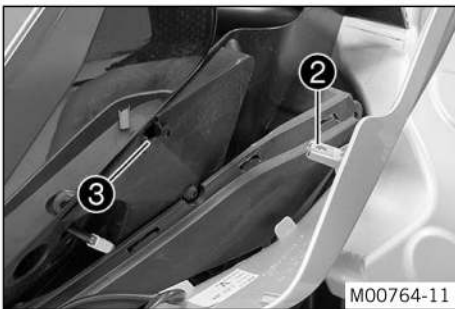

- Position the catch 2 in the bracket 3.



### Info

Ensure that the turn signal cable is placed correctly.

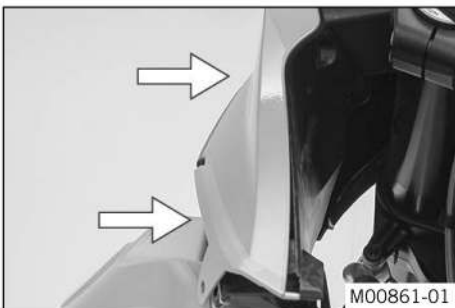

- Press the mask spoiler laterally into the supports.

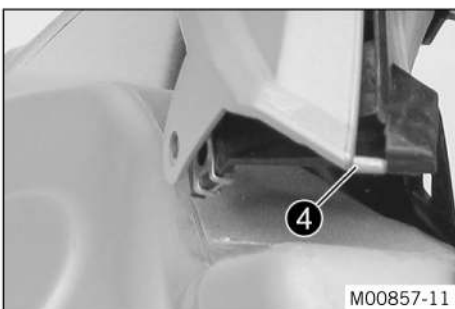

- Position holding lug 4 in the drill hole.

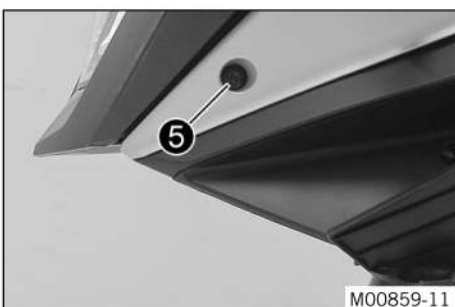

- Mount and tighten screw 5.

### Guideline

Screw, mask spoiler	M5x17	3.5 Nm (2.58 lbf ft)
---------------------	-------	-------------------------



- Mount and tighten screw 6.

Guideline

Screw, mask spoiler	M5x17	3.5 Nm (2.58 lbf ft)
---------------------	-------	-------------------------

- Repeat the operation on the opposite side.

### Finishing work

- Install the tank cover. (p. 89)
- Install the front side cover. (p. 87)
- Install the crash bar. (p. 32)
- Mount the front rider's seat. (p. 71)
- Mount the passenger seat. (p. 72)

## 13.7 Removing the bottom triple clamp cover

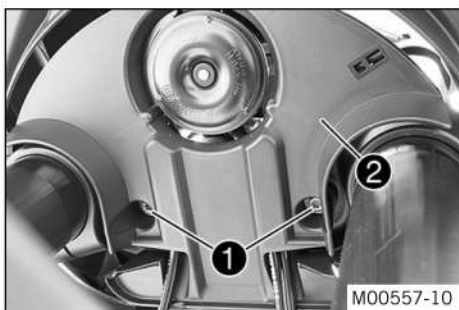

- Remove screws 1.
- Lower triple clamp cover 2 slightly.

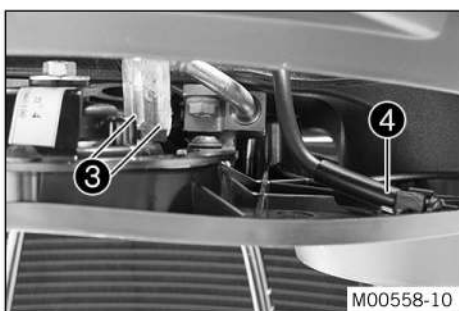

- Disconnect plugs 3 of the horn.
- Detach temperature sensor 4.
- Remove the triple clamp cover.

## 13.8 Installing the bottom triple clamp cover

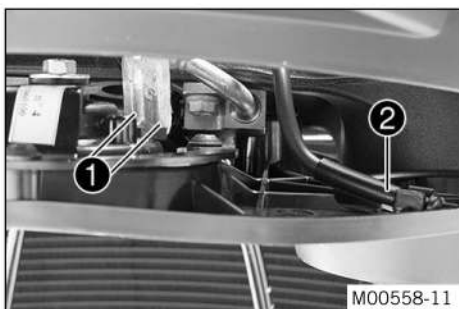

- Plug in connectors 1 of the horn.
- Attach temperature sensor 2.

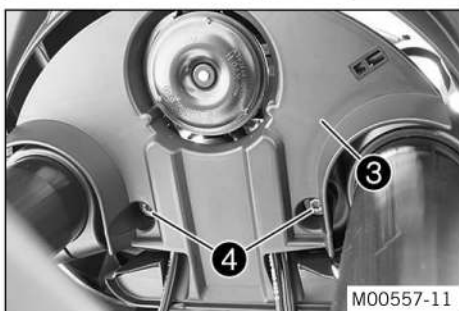

- Position the triple clamp cover 3.
- Mount and tighten screws 4.

Guideline

Remaining chassis screws	M6	10 Nm (7.4 lbf ft)
--------------------------	----	--------------------

## 13.9 Removing the front fender

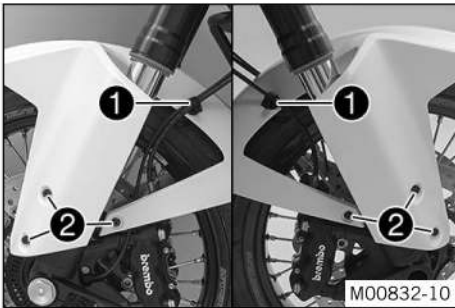

### (Super Adventure EU/FR/JP)

- Open holder ① and detach the brake lines.
- Remove screws ②.
- Take the fender off to the front.

**i Info**  
Pay attention to the brake lines.

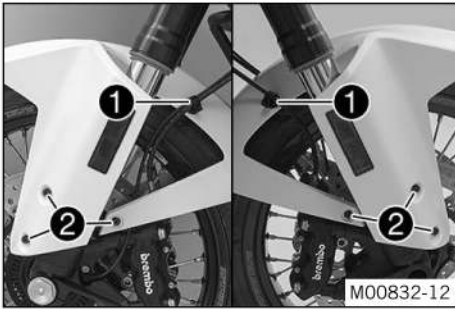

### (Super Adventure AU/US/CN)

- Open holder ① and detach the brake lines.
- Remove screws ②.
- Take the fender off to the front.

**i Info**  
Pay attention to the brake lines.

## 13.10 Installing the front fender

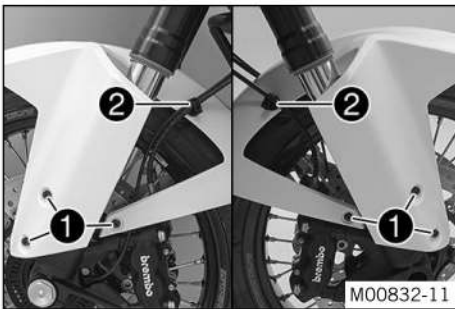

### (Super Adventure EU/FR/JP)

- Position the fender.

**i Info**  
Pay attention to where the brake lines are placed.

- Mount and tighten screws ①.

#### Guideline

Screw, fender	M5x12	3.5 Nm (2.58 lbf ft)
---------------	-------	-------------------------

- Insert the brake lines in brackets ② and close the holder.

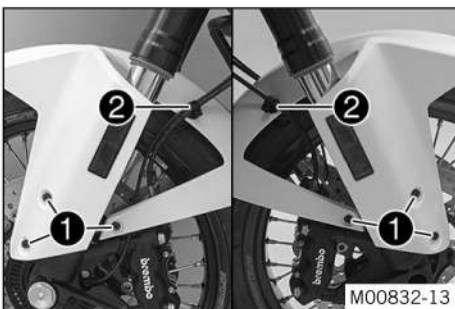

### (Super Adventure AU/US/CN)

- Position the fender.

**i Info**  
Pay attention to where the brake lines are placed.

- Mount and tighten screws ①.

#### Guideline

Screw, fender	M5x12	3.5 Nm (2.58 lbf ft)
---------------	-------	-------------------------

- Insert the brake lines in brackets ② and close the holder.

## 13.11 Removing the wind shield

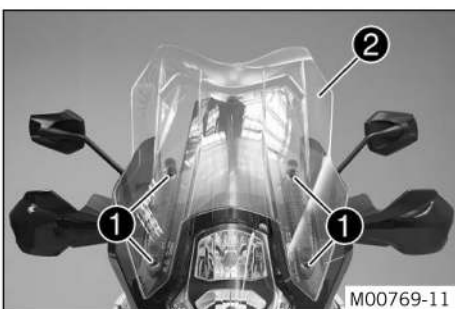

- Remove screws ① and wind shield ②.



## 13.12 Installing the wind shield

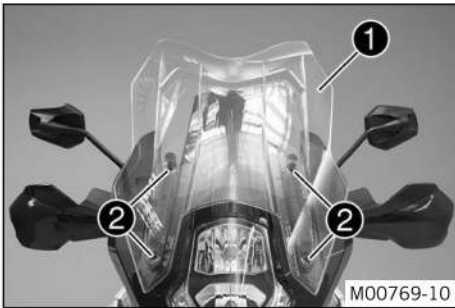

- Position wind shield ①.
- Mount and tighten screws ②.

Guideline

Screw, wind shield	M5	3.5 Nm (2.58 lbf ft)
--------------------	----	-------------------------

## 13.13 Adjusting the wind shield



- Pull clamping lever ① in the direction of the arrow.
- ✓ The windshield is unlocked.

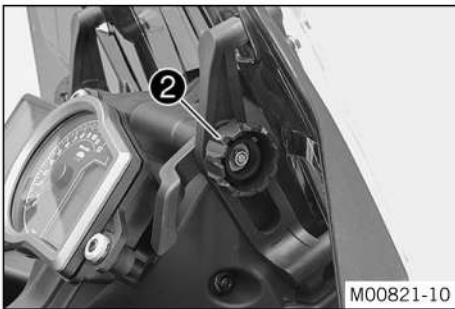

- To bring the windshield in the required position, turn the handwheel ②.

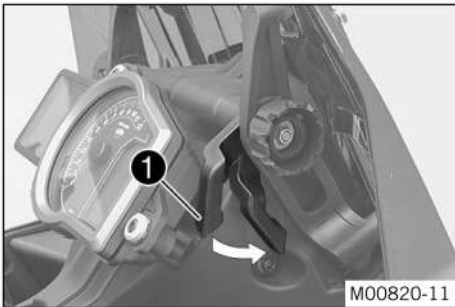

- Push clamping lever ① in the direction of the arrow.
- ✓ The windshield is locked.

## 13.14 Adjusting the windshield adapter position



### Info

To mount the windshield higher or lower the windshield adapter can be mounted in two positions.

### Preparatory work

- Remove the wind shield. (p. 94)

### Main work

- Remove screws ①.
- Take off windshield adapter ②.

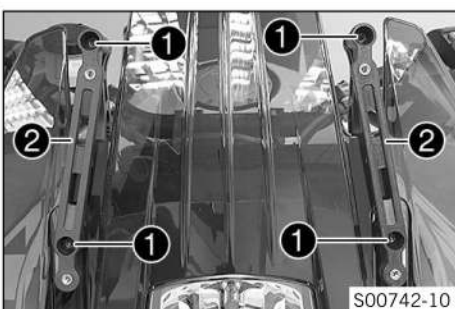

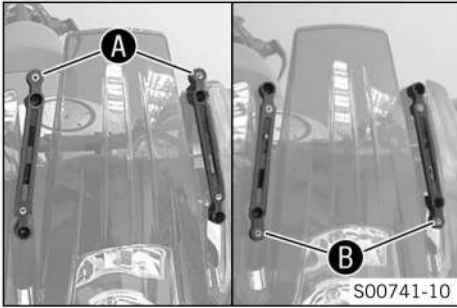

- Adjust windshield adapter to the desired position **A** or **B**.



**Info**

The handling side is marked on the rear of the windshield adapter.

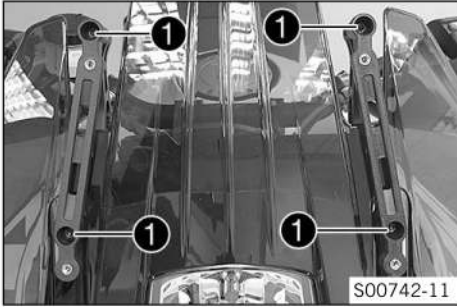

- Mount and tighten screws **1**.

Guideline

Screw, cover part	M5	3.5 Nm (2.58 lbf ft)
-------------------	----	-------------------------

**Finishing work**

- Install the wind shield. (📖 p. 95)

## 14.1 Checking the tire air pressure

**i Info**  
 Low tire air pressure leads to abnormal wear and overheating of the tire.  
 Correct tire air pressure ensures optimal riding comfort and maximum tire service life.

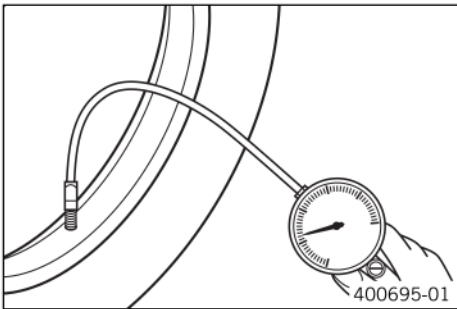

- Remove the dust cap.
- Check the tire air pressure when the tires are cold.

Tire air pressure, solo/with passenger/full payload	
Front: with cold tires	2.4 bar (35 psi)
Rear: with cold tires	2.9 bar (42 psi)

- » If the tire pressure does not meet specifications:
  - Correct the tire pressure.
- Mount the dust cap.

## 14.2 Checking the tire condition

**⚠ Warning**  
**Danger of accidents** If a tire bursts while riding, the vehicle becomes uncontrollable.  
 - Ensure that damaged or worn tires are replaced immediately.

**⚠ Warning**  
**Danger of crashing** Different tire tread patterns on the front and rear wheel impair the handling characteristic. Different tire tread patterns can make the vehicle significantly more difficult to control.  
 - Make sure that only tires with a similar tire tread pattern are fitted to the front and rear wheel.

**⚠ Warning**  
**Danger of accidents** Non-approved or non-recommended tires and wheels impact the handling characteristic.  
 - Only use tires/wheels approved by KTM with the corresponding speed index.

**⚠ Warning**  
**Danger of accidents** New tires have reduced road grip. The contact surface on new tires is not yet roughened.  
 - Run in new tires with moderate riding at alternating angles.  
 Running-in phase 200 km (124 mi)

**i Info**  
 Tire type, tire condition, and tire air pressure influence the braking and handling characteristics of the vehicle. Worn tires are particularly unfavorable on wet surfaces.

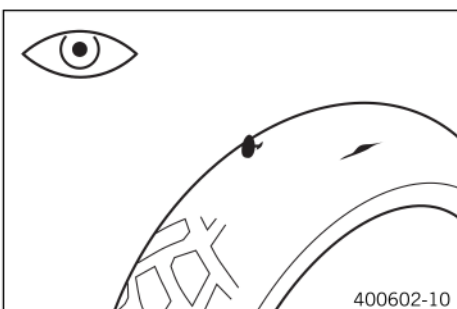

- Check the front and rear tires for cuts, run-in objects, and other damage.
  - » If the tires have cuts, run-in objects, or other damage:
    - Change the tires.
- Check the tread depth.

**i Info**  
 Adhere to the legally required minimum tread depth.

Minimum tread depth	≥ 2 mm (≥ 0.08 in)
---------------------	--------------------

- » If the tread depth is less than the minimum tread depth:
  - Change the tires.

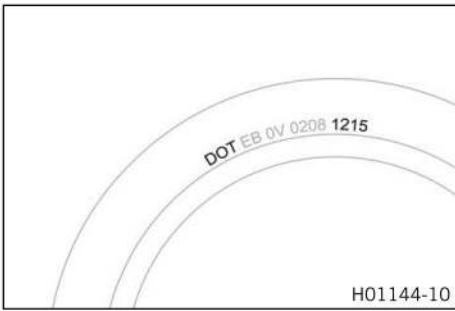

H01144-10

- Check the tire age.



**Info**

The tire date of manufacture is usually contained in the tire label and is indicated by the last four digits of the **DOT** number. The first two digits indicate the week of manufacture and the last two digits the year of manufacture.

KTM recommends that the tires be changed after 5 years at the latest, regardless of the actual state of wear.

- » If the tires are more than 5 years old:
  - Change the tires.

## 14.3 Checking the rim run-out



**Warning**

**Danger of accidents** Incorrectly tensioned spokes impair the handling characteristic and result in secondary damage.

The spokes break due to being overloaded if they are too tightly tensioned. If the tension in the spokes is too low, then lateral and radial run-out will form in the wheel. Other spokes will become looser as a result.

- Check spoke tension regularly, and in particular on a new vehicle.

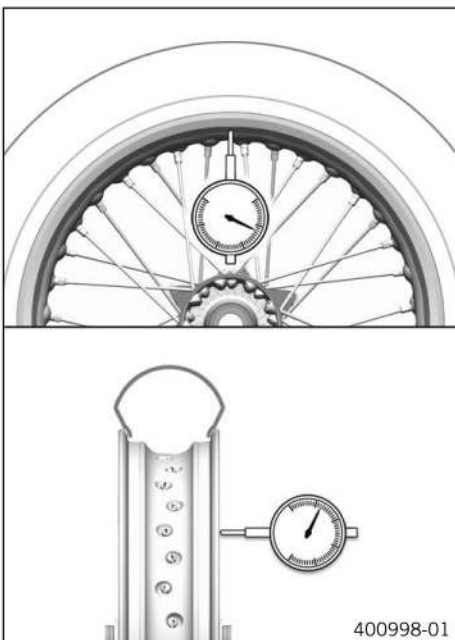

400998-01

- Check for lateral and radial run-out of the rims.

Lateral runout	
outside the rim joint	< 1.8 mm (< 0.071 in)
Radial runout	
outside the rim joint	< 1.8 mm (< 0.071 in)

- » If the measured value is greater than the specified value:
  - Center the rim.



**Info**

Center the rim by pulling the spoke nipple on the other side of the rim run-out. If there is significant deformation, change the rim.

- Correct the spoke tension.

## 14.4 Checking the wheel bearing for play

**Preparatory work**

- Raise the vehicle with the center stand. (📖 p. 12)
- Place a load on the rear of the vehicle.
- ✓ The front wheel is not in contact with the ground.

**Main work**

- Move the front wheel from side to side.



310677-10



**Info**

Hold the fork leg to check it.

- » If there is detectable play:
  - Change the front wheel bearing. (📖 p. 101)

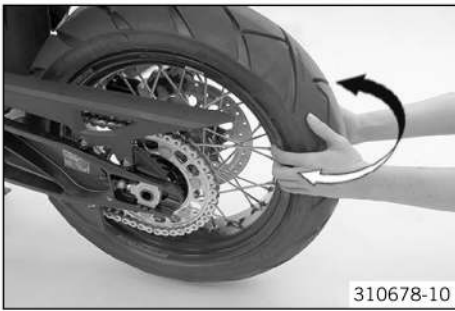

- Place a load on the front of the vehicle.
- ✓ The rear wheel is not in contact with the ground.
- Move the rear wheel from side to side.

**i Info**  
Hold the swingarm to check it.

- » If there is detectable play:
  - Change the rear wheel bearing. (📖 p. 109)

## 14.5 Checking spoke tension

**⚠ Warning**  
**Danger of accidents** Incorrectly tensioned spokes impair the handling characteristic and result in secondary damage. The spokes break due to being overloaded if they are too tightly tensioned. If the tension in the spokes is too low, then lateral and radial run-out will form in the wheel. Other spokes will become looser as a result.

- Check spoke tension regularly, and in particular on a new vehicle.

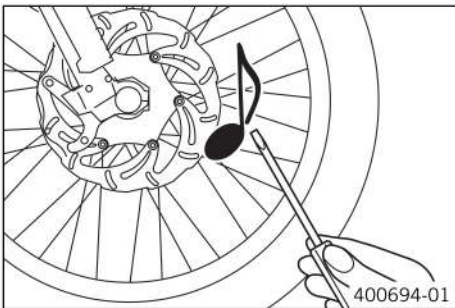

- Strike each spoke briefly using a screwdriver blade.

**i Info**  
The frequency of the sound depends on the spoke length and spoke diameter. If spokes of the same length and diameter vibrate with a different tone, this is an indication that the spoke tensions differ.

You should hear a high note.

- » If the spoke tension differs:
  - Correct the spoke tension.

## 14.6 Programming the tire pressure sensor



**Condition**  
The diagnostic tool is connected and running.

- Execute "Tire pressure monitor" > "Functions" > "Program the tire pressure sensor" > "Select the wheel".

**i Info**  
The instructions must be followed precisely.

- Clear the fault memory using the KTM diagnostics tool.
  - » Take a test ride.
    - Read out the trouble code memory using the KTM diagnostics tool.

## 14.7 Front wheel

### 14.7.1 Removing the front wheel

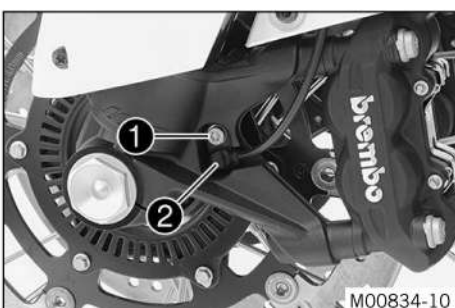

**Preparatory work**  
- Raise the vehicle with the center stand. (📖 p. 12)

**Main work**  
- Place a load on the rear of the vehicle.  
✓ The front wheel is not in contact with the ground.  
- Remove screw **1** and pull wheel speed sensor **2** out of the hole.

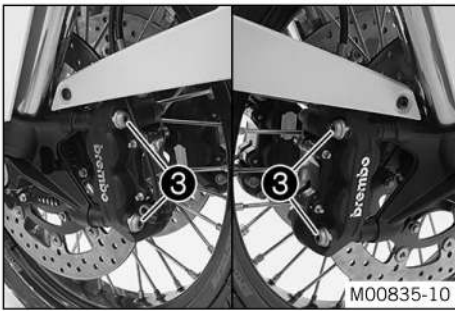

M00835-10

- Remove screws 3 from both brake calipers.
- Press back the brake linings with a slight lateral tilting of the brake calipers on the brake disc.
- Pull the brake calipers carefully back from the brake discs and hang them to one side loosely.



**Info**

Do not pull the hand brake lever when the brake caliper has been removed.

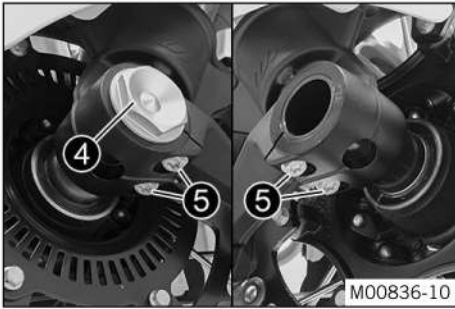

M00836-10

- Loosen screw 4 by several rotations.
- Loosen screws 5.
- Press on screw 4 to push the wheel spindle out of the axle clamp.
- Remove screw 4.



**Warning**

**Danger of accidents** Damaged brake discs reduce the braking effect.

- Always lay the wheel down in such a way that the brake discs are not damaged.

- Hold the front wheel and remove the wheel spindle. Take the front wheel out of the fork.



**Info**

Do not pull the hand brake lever when the front wheel is removed.

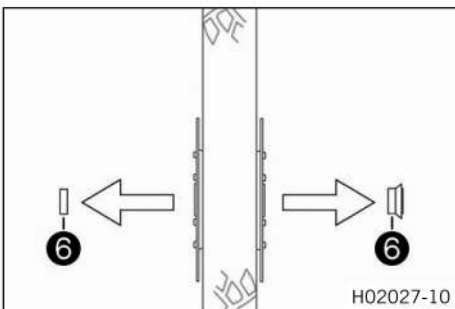

H02027-10

- Remove spacers 6.

## 14.7.2 Installing the front wheel



**Warning**

**Danger of accidents** Oil or grease on the brake discs reduces the braking effect.

- Always keep the brake discs free of oil and grease.
- Clean the brake discs with brake cleaner when necessary.

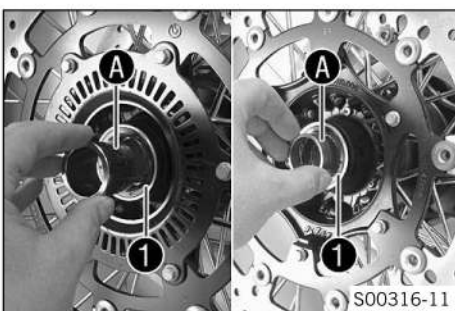

S00316-11

- Check the wheel bearing for damage and wear.
  - » If the wheel bearing is damaged or worn:
    - Change the front wheel bearing. (p. 101)
- Clean and grease shaft seal rings 1 and contact surface A of the spacers.

Long-life grease (p. 340)

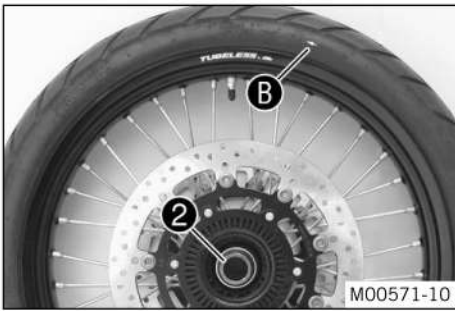

- Insert wide spacer **2** on the left in the direction of travel.

**i Info**

The arrow **B** indicates the direction of travel of the front wheel. The ABS sensor wheel is on the left-hand side when looking in the direction of travel.

- Insert the narrow spacer on the right in the direction of travel.

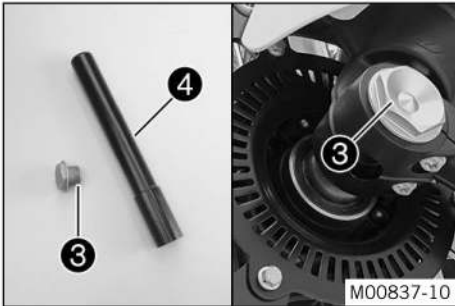

**! Warning**

**Danger of accidents** Oil or grease on the brake discs reduces the braking effect.

- Always keep the brake discs free of oil and grease.
- Clean the brake discs with brake cleaner when necessary.

- Clean and grease screw **3** and wheel spindle **4**.

Long-life grease (📖 p. 340)

- Lift the front wheel into the fork, position it, and insert the wheel spindle.
- Mount and tighten screw **3**.

Guideline

Screw, front wheel spindle	M25x1.5	45 Nm (33.2 lbf ft)	Thread greased
----------------------------	---------	------------------------	----------------

- Position the brake calipers.
  - ✓ The brake linings are correctly positioned.
- Mount screws **5** on both brake calipers but do not tighten yet.
- Operate the hand brake lever repeatedly until the brake linings are in contact with the brake disc and there is a pressure point. Fix the hand brake lever in the activated position.

✓ The brake calipers straighten.

- Tighten screws **5** on both brake calipers.

Guideline

Screw, front brake caliper	M10	45 Nm (33.2 lbf ft)	Loctite® 243™
----------------------------	-----	------------------------	---------------

- Remove the fixation of the hand brake lever.
- Position wheel speed sensor **6** in the drill hole.

- Mount and tighten screw **7**.

Guideline

Remaining chassis screws	M6	10 Nm (7.4 lbf ft)
--------------------------	----	--------------------

- Remove the vehicle from the center stand. (📖 p. 12)

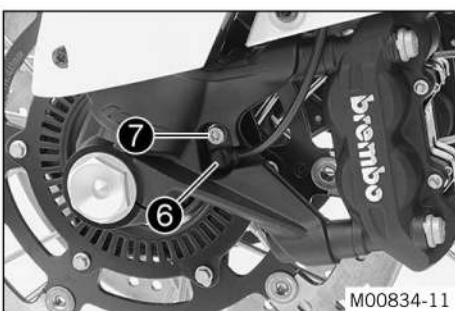
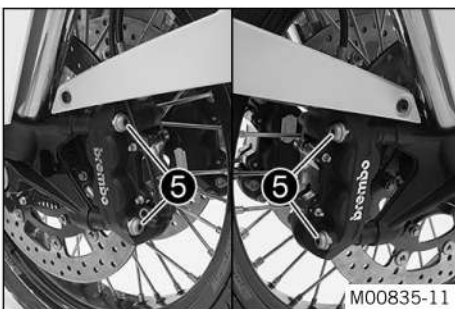

- Operate the front brake and compress the fork a few times firmly.

✓ The fork legs straighten.

- Tighten screws **8**.

Guideline

Screw, fork stub	M8	15 Nm (11.1 lbf ft)
------------------	----	------------------------

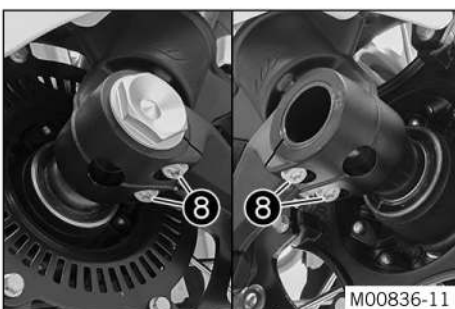

## 14.7.3 Changing the front wheel bearing

**Preparatory work**

- Raise the vehicle with the center stand. (📖 p. 12)

- Remove the front wheel. (📖 p. 99)

**Main work**

- Remove shaft seal rings ① and ②.

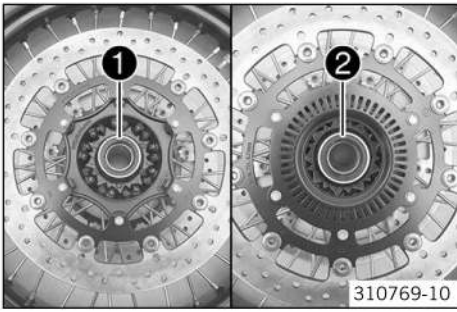

- Remove lock ring ③.

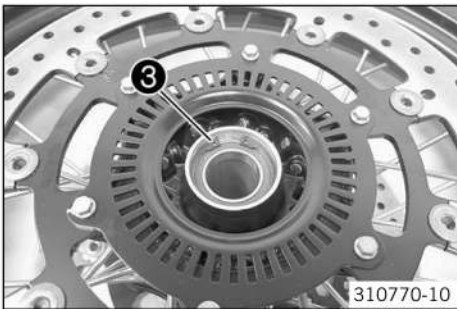

- Using a suitable tool, press bearing ④ out from the inside to the outside.
- Remove spacing tube ⑤.

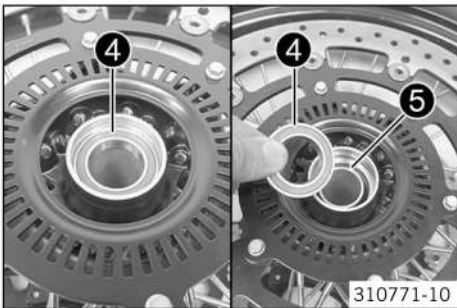

- Using a suitable tool, press bearing ⑥ out from the inside to the outside.

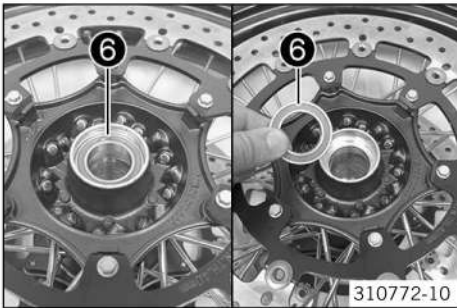

- Press new bearing ⑥ all the way in from the outside to the inside.

---

**i Info**  
Only press the bearing in via the outer ring otherwise the bearing will be damaged when it is pressed in.

---

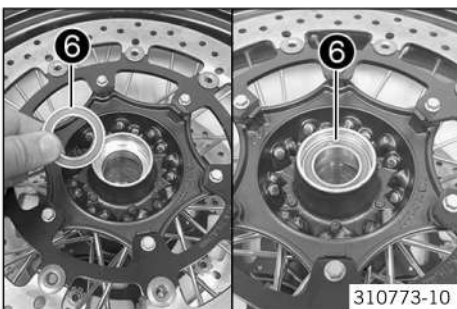

- Clean, grease, and mount spacing tube ⑤.

Long-life grease (📖 p. 340)

- Press new bearing ④ all the way in from the outside to the inside.

---

**i Info**  
Only press the bearing in via the outer ring otherwise the bearing will be damaged when it is pressed in.

---

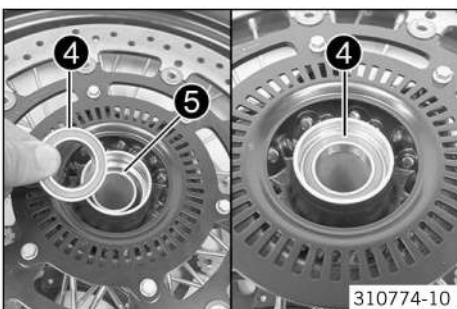



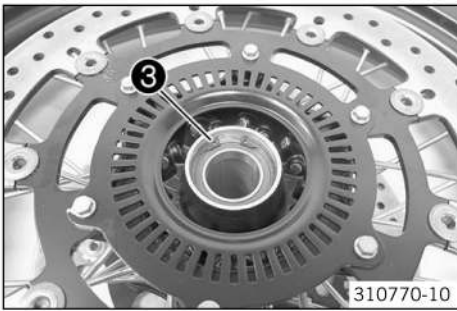

- Mount lock ring ③.
- ✓ The lock ring engages audibly.

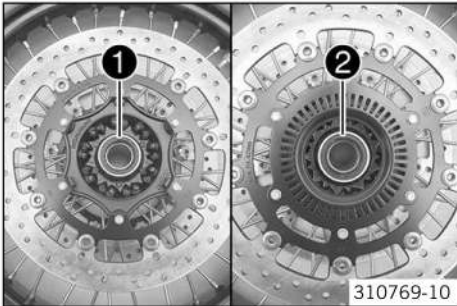

- Grease the new shaft seal rings ① and ② and press in until they are flush.

**Finishing work**

- Install the front wheel. (📖 p. 100)

**14.7.4 Tubeless tire system**

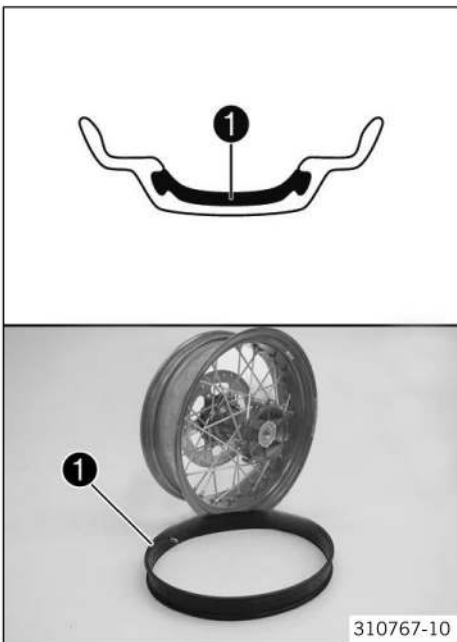

This vehicle makes use of a tubeless tire system in which a tubeless sealing profile ① is used instead of the conventional tube. The advantage of the tubeless system is that there is no risk of a defective tube. This greatly reduces the risk of a sudden loss in pressure. The masses and moments of inertia of these wheels are smaller than in conventional spoke wheels with a tube. This results in better handling and riding comfort. The rigid rim design results in a spoke wheel that is almost entirely maintenance-free. KTM recommends that the tubeless sealing profile be changed after 5 years at the latest, regardless of the actual state of wear.

**14.7.5 Changing the front tubeless sealing profile**

**Preparatory work**

- Raise the vehicle with the center stand. (📖 p. 12)
- Remove the front wheel. (📖 p. 99)
- Remove wheel.

**Main work**

- Remove nut ①.
- Take off tire pressure sensor.





- Carefully cut through the tubeless sealing profile and pull it off.



**Tip**

Raise the tubeless sealing profile slightly so that the rim tape is not damaged.

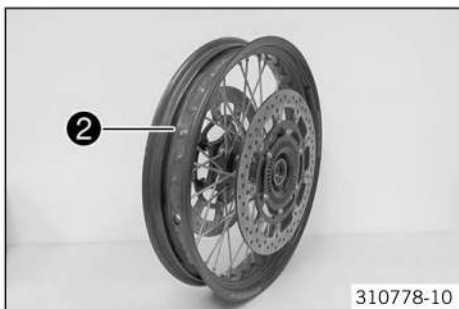

- Take off the rim tape ②.
- Clean the seal groove.
- Check the rim for damage and wear.
  - » If there is damage or wear:
    - Change the rim.
- Check the rim run-out. (🗨️ p. 98)

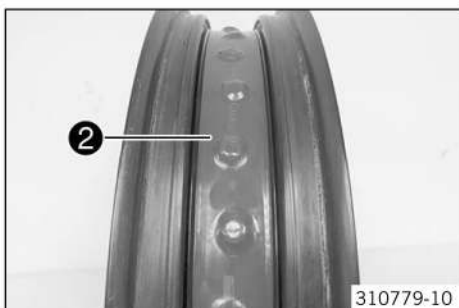

- Mount rim tape ②.



**Info**

Ensure that the rim tape is seated in exactly the right position.

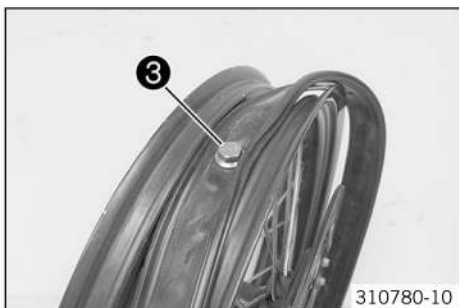

- Lubricate the seal groove lightly.

Thinned tire mounting paste

- Position tubeless sealing profile.



**Tip**

Using a suitable screw ③, secure the holes of the tubeless sealing profile and the rim together.  
Do not tighten the screw so that the seal ring is not damaged.



- Pull the tubeless sealing profile evenly over the rim.



- Align the tubeless sealing profile.
- ✓ Both sides of the tubeless sealing profile are positioned in the bottom of the seal groove.

**i Info**  
Ensure that the tubeless sealing profile does not develop folds in the longitudinal direction.

- Lubricate the tubeless sealing profile at the edges.

Thinned tire mounting paste

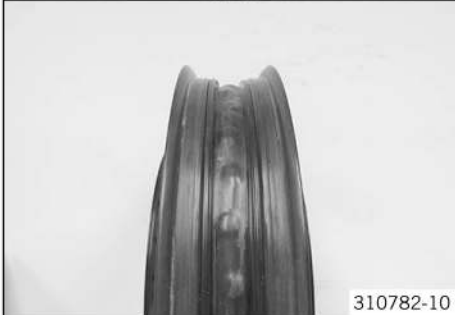

310782-10

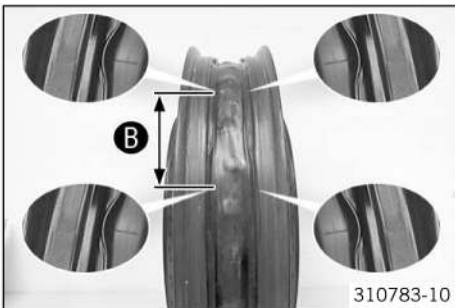

310783-10

- Using spacing **B**, press the tubeless sealing profile into the seal groove.

Guideline

15 cm (5.9 in)

**i Info**  
This step aids in positioning, making it easier to mount the tubeless sealing profile. Press perpendicular to the rim to avoid shifting the profile in a radial direction.



310784-10

- Press the tubeless sealing profile into the seal groove along the entire circumference.
- Check that the tubeless sealing profile is seated correctly around the entire circumference.
- ✓ The valve is straight.

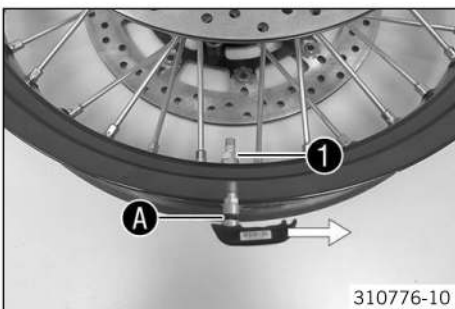

310776-10

- Grease **A** O-ring slightly.

Thinned tire mounting paste

- Position tire pressure sensor.
- ✓ Tire pressure sensor points backward in the direction of travel.
- Mount and tighten the nut **1**.

Guideline

Nut, tire pressure sensor	ISO 10V2	12 Nm (8.9 lbf ft)	Loctite® 2701™
---------------------------	----------	-----------------------	----------------

**Finishing work**

- Mount and balance tires.
- Install the front wheel. (📖 p. 100)
- Program the tire air pressure sensor. (📖 p. 99)

**14.7.6 Changing the front tire pressure sensor**

**Preparatory work**

- Raise the vehicle with the center stand. (📖 p. 12)
- Remove the front wheel. (📖 p. 99)

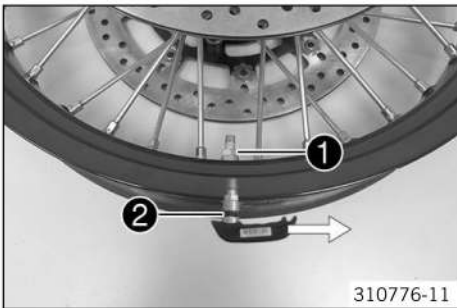
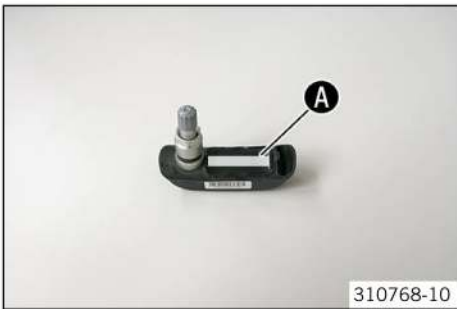

- Remove wheel.
- Main work**
- Remove nut ①.
- Take off tire pressure sensor.

- Note the ID number A of the new tire pressure sensor.

**i Info**  
The ID number is used to program the tire pressure sensor.

- Grease ② O-ring slightly.
- Position new tire pressure sensor.
- ✓ Tire pressure sensor points backward in the direction of travel.
- Mount and tighten the nut ①.

Thinned tire mounting paste

Guideline

Nut, tire pressure sensor	ISO 10V2	12 Nm (8.9 lbf ft)	Loctite® 2701™
---------------------------	----------	-----------------------	----------------

- Finishing work**
- Mount and balance tires.
  - Install the front wheel. (📖 p. 100)
  - Program the tire air pressure sensor. (📖 p. 99)

## 14.7.7 Checking the brake discs

**⚠ Warning**  
**Danger of accidents** Worn-out brake discs reduce the braking effect.

- Make sure that worn-out brake discs are replaced immediately.

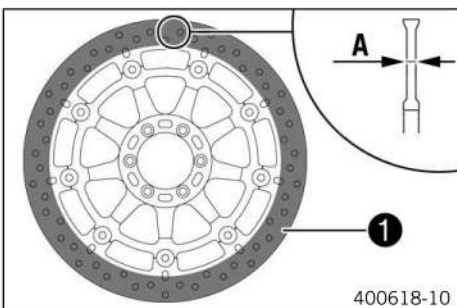

- Check the thickness of the front and rear brake discs at multiple points on each brake disc to ensure it is at least thickness A.

**i Info**  
Wear will reduce the thickness of the brake disc at the contact surface ① of the brake linings.

Brake discs - wear limit	
Front	4 mm (0.16 in)
Rear	4.5 mm (0.177 in)

- » If the brake disc thickness is less than the specified value.
  - Change the front brake discs. (📖 p. 107)
  - Change the rear brake discs. (📖 p. 114)
- Check the front and rear brake discs for damage, cracking, and deformation.
  - » If the brake disc exhibits damage, cracking, or deformation:
    - Change the front brake discs. (📖 p. 107)
    - Change the rear brake discs. (📖 p. 114)

## 14.7.8 Changing the front brake discs

### Preparatory work

- Raise the vehicle with the center stand. (📖 p. 12)
- Remove the front wheel. (📖 p. 99)

### Main work

- Remove screws ❶. Take off the right-hand brake disc.

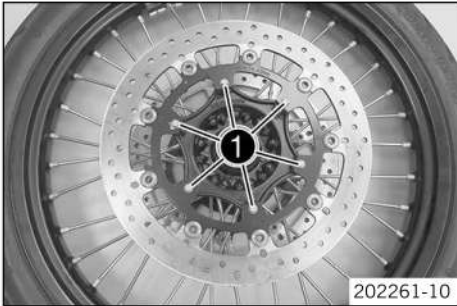

- Remove screws ❷. Remove left-hand brake disc with ABS sensor wheel ❸.

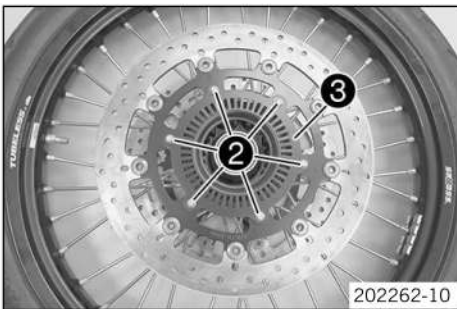

- Clean the contact surface of the brake disc.
- Position the brake disc with the label facing outward. Mount and tighten screws ❶.

#### Guideline

Screw, front brake disc	M6	14 Nm (10.3 lbf ft)	Loctite® 243™
-------------------------	----	------------------------	---------------

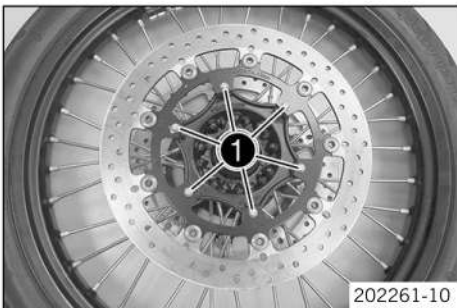

- Clean the contact surface of the brake disc.
- Position the brake disc with the label facing outward. Position the ABS sensor wheel ❸. Mount and tighten screws ❷.

#### Guideline

Screw, front brake disc	M6	14 Nm (10.3 lbf ft)	Loctite® 243™
-------------------------	----	------------------------	---------------

- ✓ The ABS sensor wheel is on the left-hand side when looking in the direction of travel.

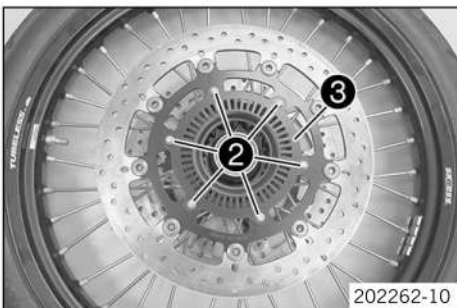

### Finishing work

- Install the front wheel. (📖 p. 100)

## 14.8 Rear wheel

### 14.8.1 Removing the rear wheel

#### Preparatory work

- Raise the vehicle with the center stand. (📖 p. 12)

#### Main work

- Press the brake caliper onto the brake disc by hand in order to push back the brake pistons.

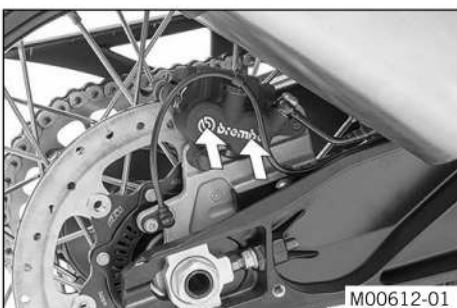

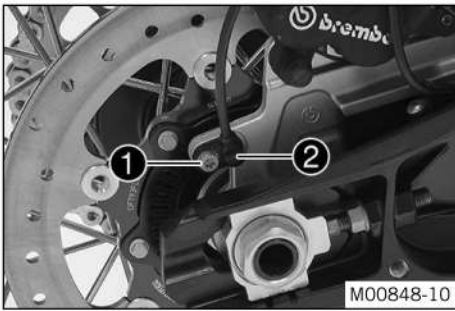

- Remove screw ① and pull wheel speed sensor ② out of the hole.

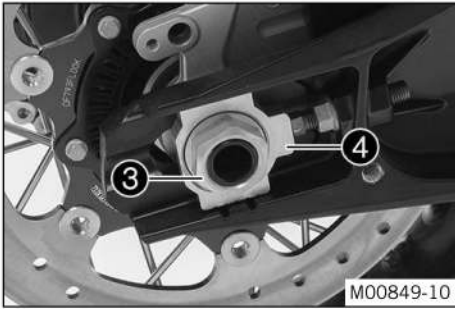

- Remove nut ③. Remove chain adjuster ④.

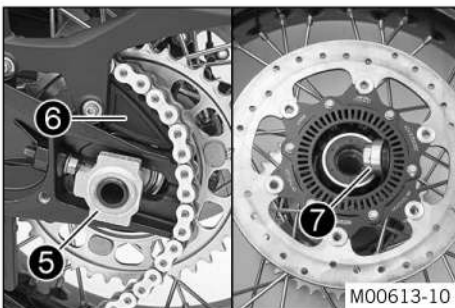

- Withdraw wheel spindle ⑤ only enough to allow the rear wheel to be pushed forward.
- Push the rear wheel forward as far as possible. Take the chain off of the rear sprocket and place it on chain sprocket guard ⑥.



**Warning**

**Danger of accidents** Reduced braking effect caused by damaged brake discs.

- Always lay the wheel down in such a way that the brake discs are not damaged.

- Holding the rear wheel, withdraw the wheel spindle. Take the rear wheel out of the swingarm.



**Info**

Do not operate the foot brake when the rear wheel is removed.

- Remove spacer ⑦.

## 14.8.2 Installing the rear wheel



**Warning**

**Danger of accidents** Oil or grease on the brake discs reduces the braking effect.

- Always keep the brake discs free of oil and grease.
- Clean the brake discs with brake cleaner when necessary.



**Warning**

**Danger of accidents** There is no braking effect to start with at the rear brake after installing the rear wheel.

- Actuate the foot brake several times before going on a ride until you can feel a firm pressure point.

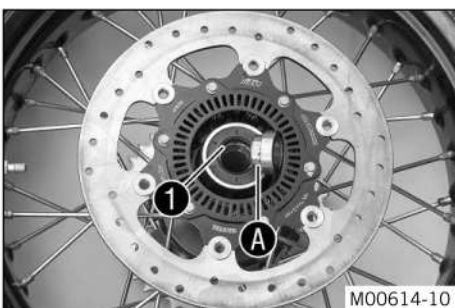

- Check the rear hub rubber dampers. (📖 p. 118)
- Check the wheel bearing for damage and wear.
  - » If the wheel bearing is damaged or worn:
    - Change the rear wheel bearing. (📖 p. 109)
- Clean and grease shaft seal ring ① and contact surface A of the spacer.

Long-life grease (📖 p. 340)

- Insert the spacer.
- Clean and grease the thread of the wheel spindle and nut.

Long-life grease (📖 p. 340)

- Install the rubber dampers and rear sprocket carrier on the rear wheel.
- Place the rear wheel in the swingarm and bring the brake disc into contact with the brake caliper.
- Mount wheel spindle ② but do not push it in all the way.
- Push the rear wheel forward as far as possible and lay the chain on the rear sprocket.

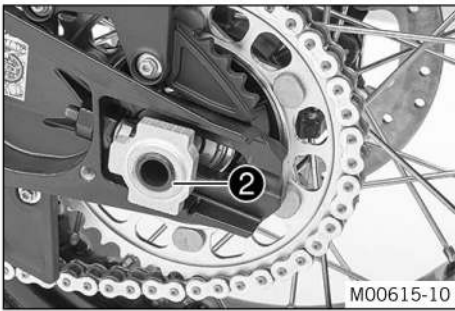

- Push the wheel spindle in all the way and mount chain adjuster ④ and nut ⑤.

**i Info**

Mount chain adjusters ③ and ④ in the same position.

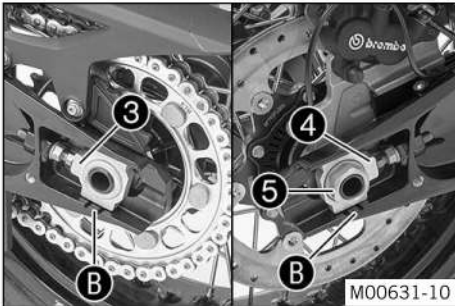

- Make sure that the chain adjusters are fitted correctly on the adjusting screws.

**Guideline**  
In order for the rear wheel to be correctly aligned, the markings on the left and right chain adjusters must be in the same position relative to reference markings B.

- Tighten nut ⑤.

**Guideline**

Nut, rear wheel spindle	M25x1.5	90 Nm (66.4 lbf ft)	Thread greased
-------------------------	---------	------------------------	----------------

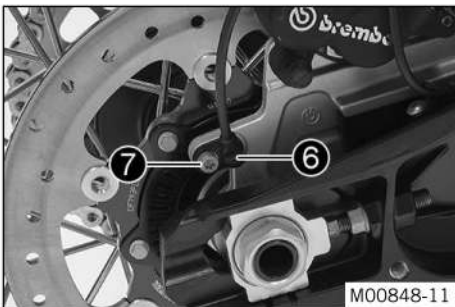

- Position wheel speed sensor ⑥ in the drill hole.
- Mount and tighten screw ⑦.

**Guideline**

Remaining chassis screws	M6	10 Nm (7.4 lbf ft)
--------------------------	----	--------------------

- Operate the foot brake lever repeatedly until the brake linings are in contact with the brake disc and there is a pressure point.

### 14.8.3 Changing the rear wheel bearing

**Preparatory work**

- Raise the vehicle with the center stand. (📖 p. 12)
- Remove the rear wheel. (📖 p. 107)

**Main work**

- Remove rear sprocket carrier ①.

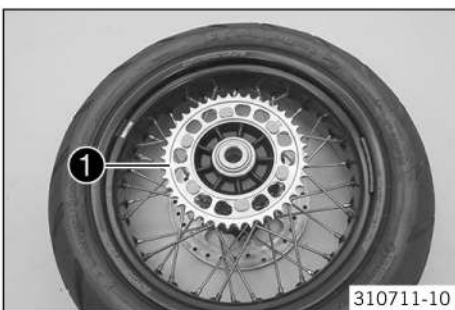



- Check both bearings **2** for damage and wear.
  - » If the bearings are damaged or worn:
    - Change the bearing of the rear sprocket carrier. (📖 p. 119)

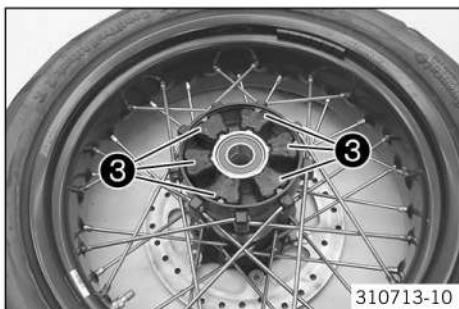

- Remove rubber dampers **3**.

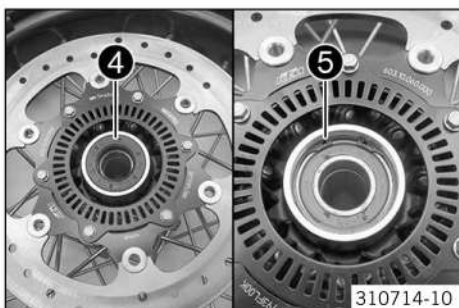

- Remove shaft seal ring **4**.
- Remove lock ring **5**.

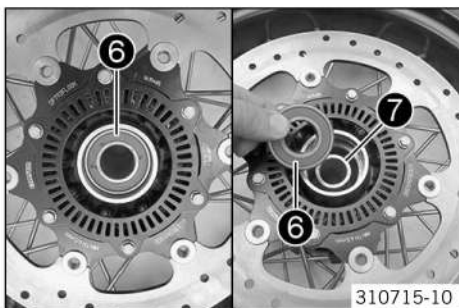

- Using a suitable tool, press bearing **6** out from the inside to the outside.
- Remove spacing tube **7**.

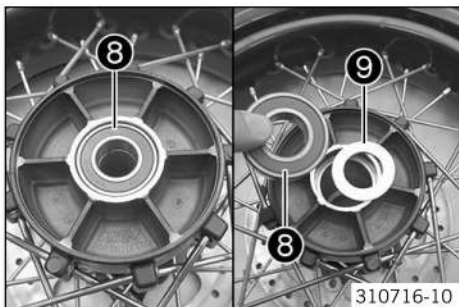

- Using a suitable tool, press bearing **8** out from the inside to the outside.
- Check spacer washer **9** for damage and wear.
  - » If the spacer washer is damaged or worn:
    - Replace the spacer washer.

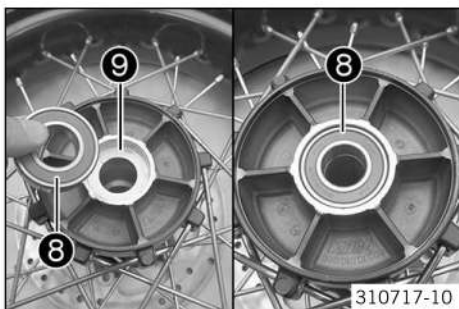

- Position spacer washer **9**.
- Press new bearing **8** all the way in from the outside to the inside.

---

**i Info**  
Only press the bearing in via the outer ring otherwise the bearing will be damaged when it is pressed in.

---



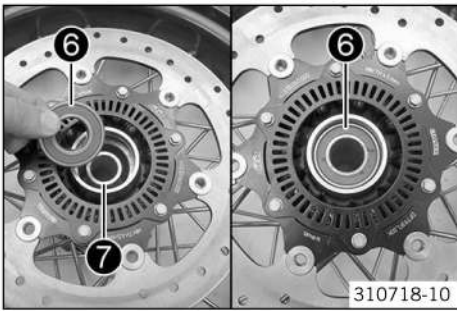

- Clean, grease, and mount spacing tube 7.

Long-life grease (🔧 p. 340)

- Press new bearing 6 all the way in from the outside to the inside.



**Info**

Only press the bearing in via the outer ring otherwise the bearing will be damaged when it is pressed in.

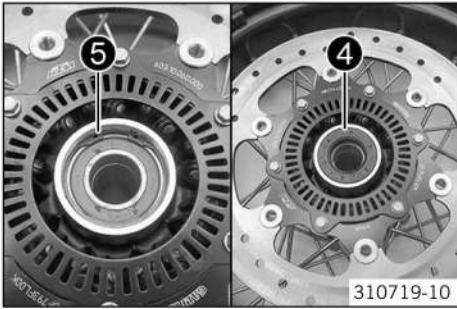

- Mount lock ring 5.

✓ The lock ring engages audibly.

- Grease new shaft seal ring 4 and press it in until it is flush.

Long-life grease (🔧 p. 340)

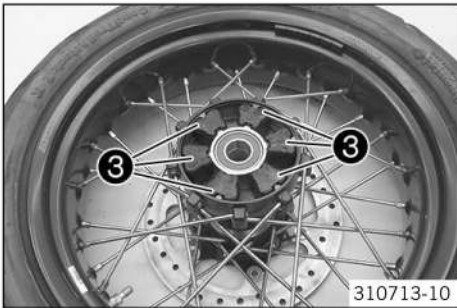

- Position rubber dampers 3.

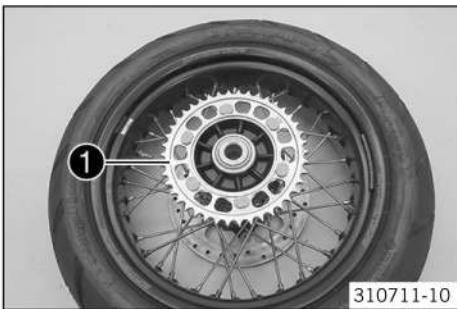

- Mount rear sprocket carriers 1.

**Finishing work**

- Install the rear wheel. (🔧 p. 108)

## 14.8.4 Changing the rear tubeless sealing profile

**Preparatory work**

- Raise the vehicle with the center stand. (🔧 p. 12)
- Remove the rear wheel. (🔧 p. 107)
- Take off the rear sprocket carrier and rubber dampers.
- Remove wheel.

**Main work**

- Remove nut 1.
- Take off tire pressure sensor.

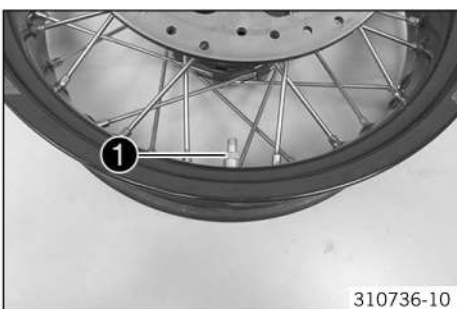



- Carefully cut through the tubeless sealing profile and pull it off.



**Tip**

Raise the tubeless sealing profile slightly so that the rim tape is not damaged.

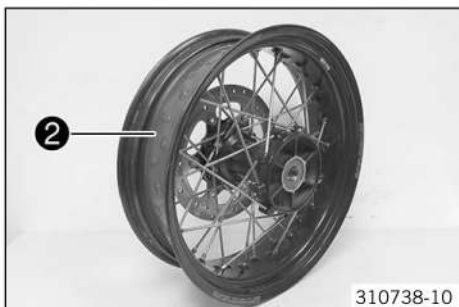

- Take off the rim tape ②.
- Clean the seal groove.
- Check the rim for damage and wear.
  - » If there is damage or wear:
    - Change the rim.
- Check the rim run-out. (🔊 p. 98)

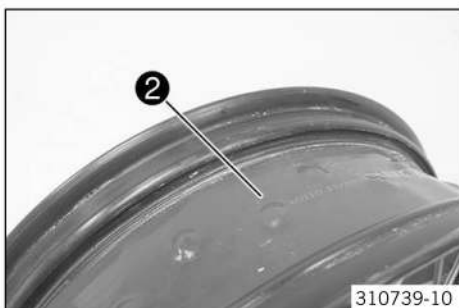

- Mount rim tape ②.



**Info**

Ensure that the rim tape is seated in exactly the right position.

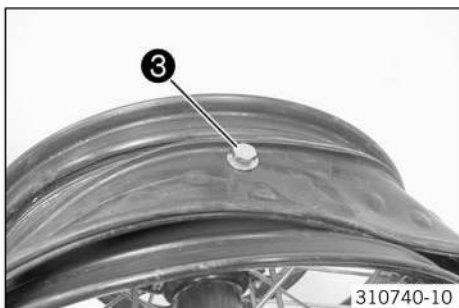

- Lubricate the seal groove lightly.

Thinned tire mounting paste

- Position tubeless sealing profile.



**Tip**

Using a suitable screw ③, secure the holes of the tubeless sealing profile and the rim together.  
Do not tighten the screw so that the seal ring is not damaged.



- Pull the tubeless sealing profile evenly over the rim.



- Align the tubeless sealing profile.
  - ✓ Both sides of the tubeless sealing profile are positioned in the bottom of the seal groove.
  - ✓ Markings ④ are aligned along the entire circumference of the rim.

**i Info**

Ensure that the tubeless sealing profile does not develop folds in the longitudinal direction.

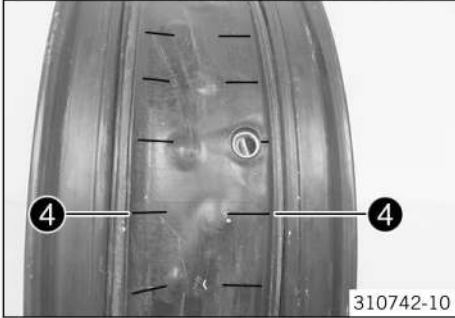

- Lubricate the tubeless sealing profile at the edges.

Thinned tire mounting paste

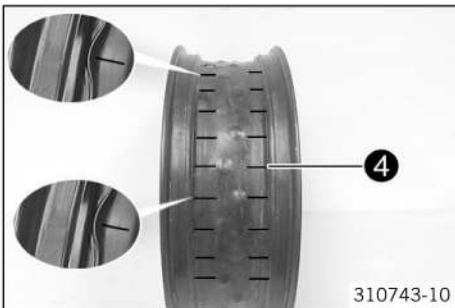

- Press the tubeless sealing profile into the seal groove at intervals that are 5 markings ④ apart.

**i Info**

This step aids in positioning, making it easier to mount the tubeless sealing profile. Press perpendicular to the rim to avoid shifting the profile in a radial direction.



- Press the tubeless sealing profile into the seal groove along the entire circumference.
- Check that the tubeless sealing profile is seated correctly around the entire circumference.
  - ✓ The valve is straight.

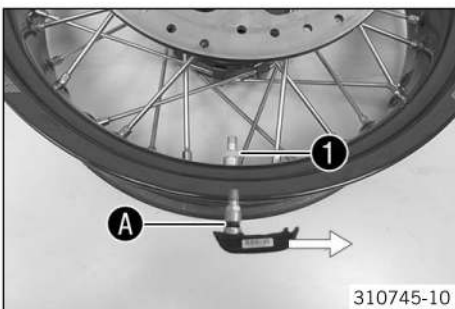

- Grease A O-ring slightly.

Thinned tire mounting paste

- Position tire pressure sensor.
  - ✓ Tire pressure sensor points backward in the direction of travel.
- Mount and tighten the nut ①.

Guideline

Nut, tire pressure sensor	ISO 10V2	12 Nm (8.9 lbf ft)	Loctite® 2701™
---------------------------	----------	-----------------------	----------------

**Finishing work**

- Mount and balance tires.
- Install the rubber dampers and rear sprocket carrier.
- Install the rear wheel. (📖 p. 108)
- Program the tire air pressure sensor. (📖 p. 99)

## 14.8.5 Changing the rear tire pressure sensor

**Preparatory work**

- Raise the vehicle with the center stand. (📖 p. 12)
- Remove the rear wheel. (📖 p. 107)

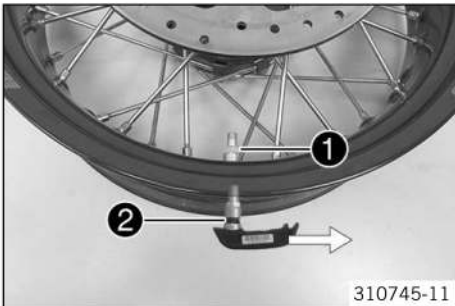
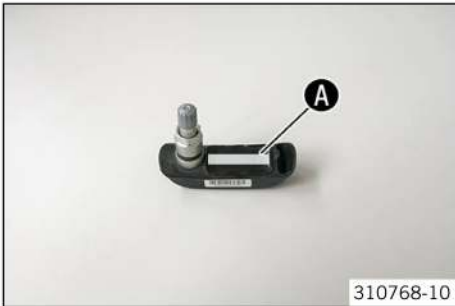
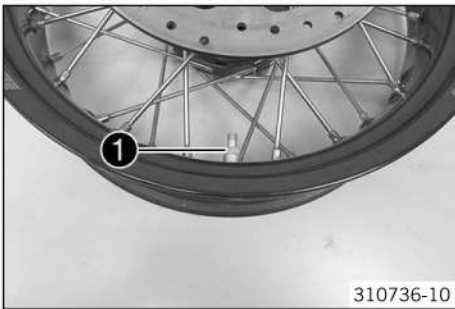

- Take off the rear sprocket carrier and rubber dampers.
- Remove wheel.

**Main work**

- Remove nut 1.
- Take off tire pressure sensor.

- Note the ID number A of the new tire pressure sensor.



**Info**

The ID number is used to program the tire pressure sensor.

- Grease 2 O-ring slightly.

Thinned tire mounting paste

- Position new tire pressure sensor.
- ✓ Tire pressure sensor points backward in the direction of travel.
- Mount and tighten the nut 1.

**Guideline**

Nut, tire pressure sensor	ISO 10V2	12 Nm (8.9 lbf ft)	Loctite® 2701™
---------------------------	----------	-----------------------	----------------

**Finishing work**

- Mount and balance tires.
- Install the rubber dampers and rear sprocket carrier.
- Install the rear wheel. (📖 p. 108)
- Program the tire air pressure sensor. (📖 p. 99)

**14.8.6 Changing the rear brake discs**

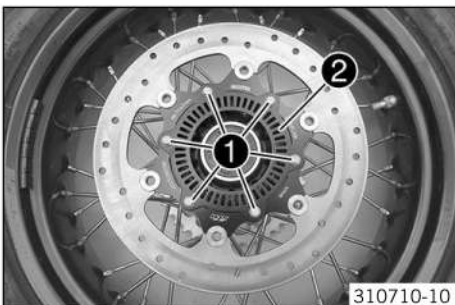

**Preparatory work**

- Raise the vehicle with the center stand. (📖 p. 12)
- Remove the rear wheel. (📖 p. 107)

**Main work**

- Remove screws 1.
- Remove brake disc with ABS sensor wheel 2.
- Clean the contact surface of the brake disc.
- Position the new brake disc with the label facing outward.
- Position ABS sensor wheel 2.
- Mount and tighten screws 1.

**Guideline**

Screw, rear brake disc	M6	14 Nm (10.3 lbf ft)	Loctite® 243™
------------------------	----	------------------------	---------------

**Finishing work**

- Install the rear wheel. (📖 p. 108)

## 14.8.7 Checking the chain tension

**Warning**  
**Danger of accidents** Incorrect chain tension damages components and results in accidents.  
 If the chain is tensioned too much, the chain, engine sprocket, rear sprocket, transmission and rear wheel bearings wear more quickly. Some components may break if overloaded.  
 If the chain is too loose, the chain may fall off the engine sprocket or the rear sprocket. As a result, the rear wheel locks or the engine will be damaged.

- Check the chain tension regularly.
- Set the chain tension in accordance with the specification.

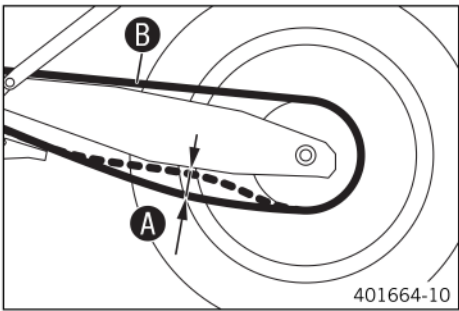

**Preparatory work**

- Raise the vehicle with the center stand. (📖 p. 12)

**Main work**

- Shift the transmission to idle **N**.
- In the area in front of the chain guide, push the chain up and determine chain tension **A**.

**i Info**  
 The upper part of the chain **B** must be taut.  
 Chain wear is not always even, so you should repeat this measurement at different chain positions.

Chain tension	40... 45 mm (1.57... 1.77 in)
---------------	-------------------------------

» If the chain tension does not meet the specification:

- Adjust the chain tension. (📖 p. 115)

**Finishing work**

- Remove the vehicle from the center stand. (📖 p. 12)

## 14.8.8 Adjusting the chain tension

**Warning**  
**Danger of accidents** Incorrect chain tension damages components and results in accidents.  
 If the chain is tensioned too much, the chain, engine sprocket, rear sprocket, transmission and rear wheel bearings wear more quickly. Some components may break if overloaded.  
 If the chain is too loose, the chain may fall off the engine sprocket or the rear sprocket. As a result, the rear wheel locks or the engine will be damaged.

- Check the chain tension regularly.
- Set the chain tension in accordance with the specification.

**Preparatory work**

- Raise the vehicle with the center stand. (📖 p. 12)
- Check the chain tension. (📖 p. 115)

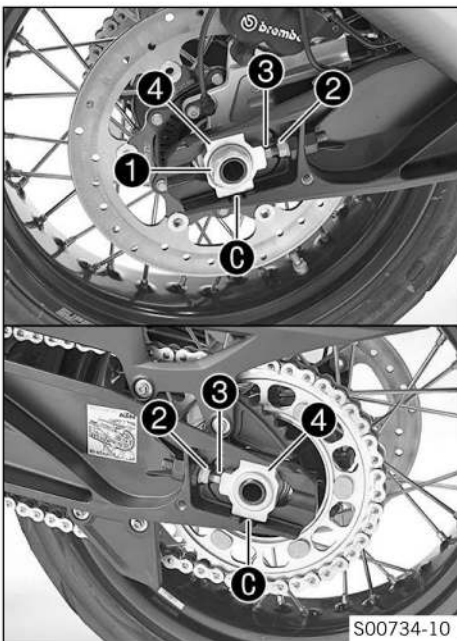

**Main work**

- Loosen nut ①.
- Loosen nuts ②.
- Adjust the chain tension by turning the adjusting screws ③ on the left and right.

**Guideline**

Chain tension	40... 45 mm (1.57... 1.77 in)
Turn adjusting screws ③ on the left and right so that the markings on the left and right chain adjusters ④ are in the same position relative to reference marks ⑥. The rear wheel is then correctly aligned.	



**Info**

The upper part of the chain must be taut. Chain wear is not always even, so you should check the setting at different chain positions.

- Tighten nuts ②.
- Make sure that chain adjusters ④ are resting against adjusting screws ③.
- Tighten nut ①.

**Guideline**

Nut, rear wheel spindle	M25x1.5	90 Nm (66.4 lbf ft)	Thread greased
-------------------------	---------	---------------------	----------------



**Info**

Chain adjusters ④ can be turned through 180°.

**Finishing work**

- Remove the vehicle from the center stand. (📖 p. 12)

**14.8.9 Checking the chain, rear sprocket and engine sprocket**

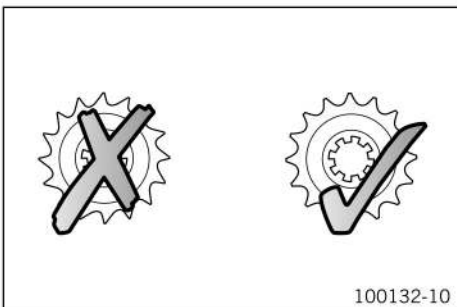

**Preparatory work**

- Raise the vehicle with the center stand. (📖 p. 12)

**Main work**

- Check the rear sprocket and engine sprocket for wear.
  - » If the rear sprocket or engine sprocket is worn:
    - Change the drivetrain kit. (📖 p. 121)



**Info**

The rear sprocket, engine sprocket and chain should always be changed together.

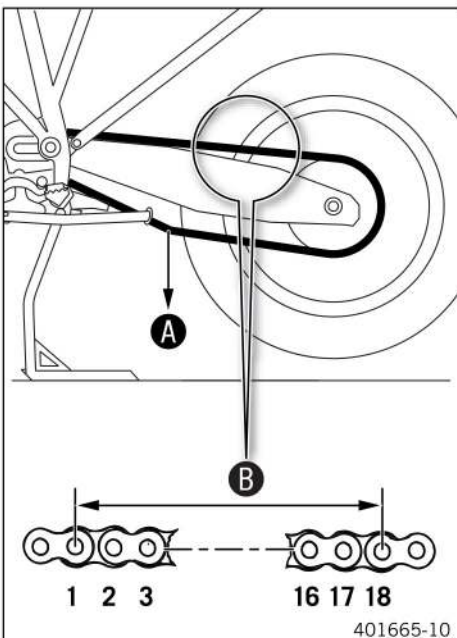

- Shift the transmission to idle N.
- Pull the lower chain section with specified weight A.

**Guideline**

Weight, chain wear measurement	15 kg (33 lb.)
--------------------------------	----------------

- Measure distance B of 18 chain rollers on the upper part of the chain.



**Info**

Chain wear is not always even, so you should repeat this measurement at different chain positions.

Maximum distance B at the longest chain section	272 mm (10.71 in)
---	-------------------

- » If distance B is greater than the specified measurement:
  - Change the drivetrain kit. (📖 p. 121)

**i Info**  
 When the chain is replaced, the rear sprocket and engine sprocket should also be changed.  
 New chains wear out faster on old, worn sprockets.  
 For safety reasons, the chain has no chain joint.

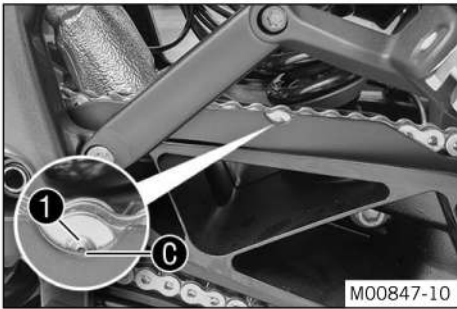

- Check the chain sliding guard for wear at the cutout.

**i Info**  
 When the chain sliding guard is new, the rivets **1** are half visible at the bottom edge **C** of the recess.

- » When the rivets of the chain are no longer visible at the bottom edge of the recess of the chain sliding guard:
  - Change the chain sliding guard.

- Check the chain sliding guard for tightness.
  - » If the chain sliding guard is loose:
    - Tighten the screws on the chain sliding guard.

Guideline

Screw, chain sliding guard	M5	5 Nm (3.7 lbf ft)
----------------------------	----	----------------------

- Check the chain guide for wear.
  - » If the chain guide is worn:
    - Change the chain guide.
- Check the chain guide for tightness.
  - » If the chain guide is loose:
    - Tighten the screws on the chain guide.

Guideline

Screw, chain guide	M6	5 Nm (3.7 lbf ft)
--------------------	----	----------------------



**Finishing work**

- Remove the vehicle from the center stand. (📖 p. 12)

**14.8.10 Cleaning the chain**

**⚠ Warning**  
**Danger of accidents** Oil or grease on the tires reduces the road grip.  
 - Remove the lubricant from the tires using a suitable cleaning agent.

**⚠ Warning**  
**Danger of accidents** Oil or grease on the brake discs reduces the braking effect.  
 - Always keep the brake discs free of oil and grease.  
 - Clean the brake discs with brake cleaner when necessary.

**🌿 Warning**  
**Environmental hazard** Hazardous substances cause environmental damage.  
 - Dispose of oils, grease, filters, fuel, cleaning agents, brake fluid, etc., correctly and in compliance with the applicable regulations.

**i Info**  
 The service life of the chain depends largely on its maintenance.

**Preparatory work**

- Raise the vehicle with the center stand. (📖 p. 12)

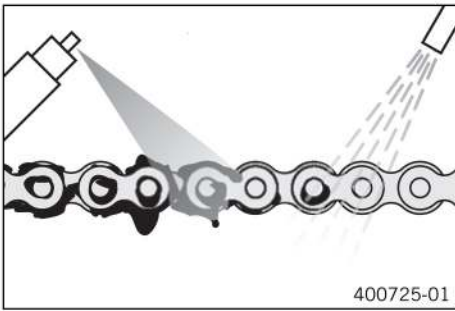

**Main work**

- Clean the chain regularly.
- Rinse off loose dirt with a soft jet of water.
- Remove old grease remains with chain cleaner.

Chain cleaner (📖 p. 340)

- After drying, apply chain spray.

Chain lube for road use (📖 p. 340)

**Finishing work**

- Remove the vehicle from the center stand. (📖 p. 12)

**14.8.11 Checking the rear hub rubber dampers**

**i Info**

The engine power is transmitted from the rear sprocket to the rear wheel via 6 rubber dampers. The rubber dampers wear out during operation. If the rubber dampers are not changed in time, the rear sprocket carrier and the rear hub will be damaged.

**Preparatory work**

- Raise the vehicle with the center stand. (📖 p. 12)
- Remove the rear wheel. (📖 p. 107)

**Main work**

- Lay the rear wheel on a workbench with the rear sprocket facing upwards and insert the wheel spindle in the hub.
- Check the rear sprocket play **A**.

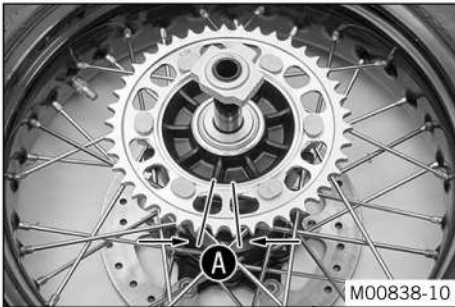

**i Info**

Measure the play on the outside of the rear sprocket.

Play in rubber dampers, rear wheel	≤ 5 mm (≤ 0.2 in)
------------------------------------	-------------------

- » If clearance **A** is larger than the specified value:
  - Change all rubber dampers in the rear hub. (📖 p. 118)

**Finishing work**

- Install the rear wheel. (📖 p. 108)

**14.8.12 Changing the rubber dampers in the rear hub**

**Preparatory work**

- Raise the vehicle with the center stand. (📖 p. 12)
- Remove the rear wheel. (📖 p. 107)

**Main work**

- Remove rear sprocket carrier **1**.

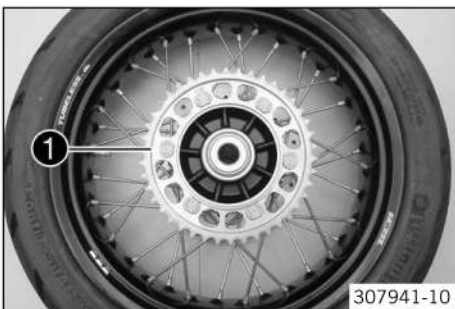

- Remove all rubber dampers **2**.
- Position new rubber dampers.

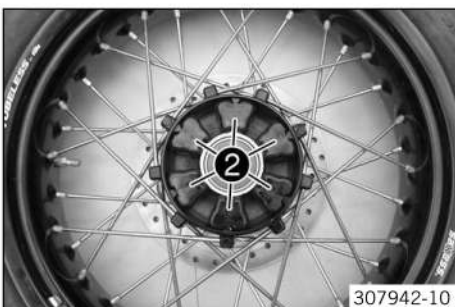



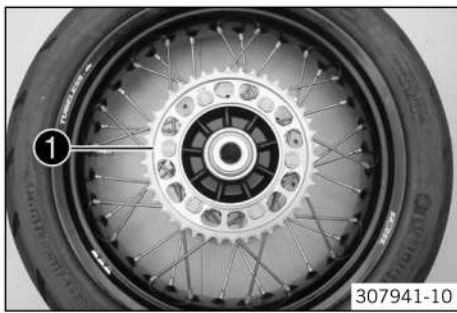

- Mount rear sprocket carriers ①.

**Finishing work**

- Install the rear wheel. (📖 p. 108)

### 14.8.13 Changing the bearing of the rear sprocket carrier

**Condition**

Rear sprocket carrier is removed.

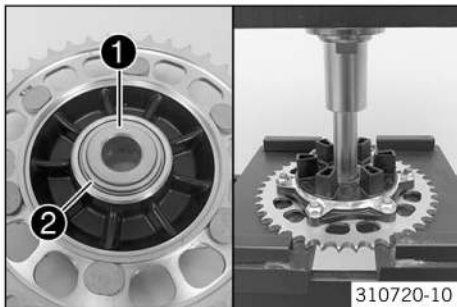

- Using a shim ②, press distance sleeve ① from the inside to the outside.

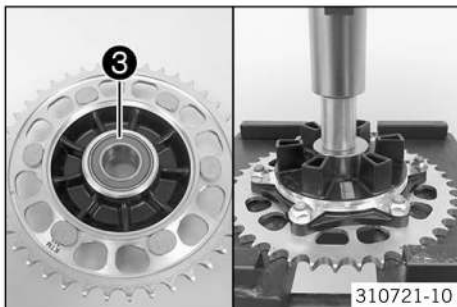

- Using a suitable tool, press both bearings ③ out from the inside to the outside.

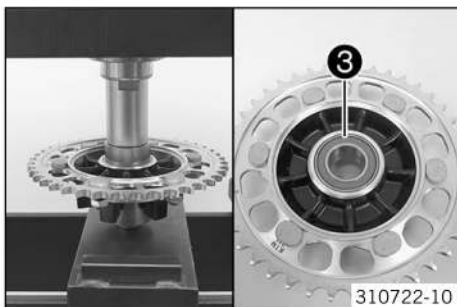

- Using a suitable tool, press in both bearings ③ from the outside to the inside until it is flush.



**Info**

Support rear sprocket carrier in the area of the bearing to avoid damage.

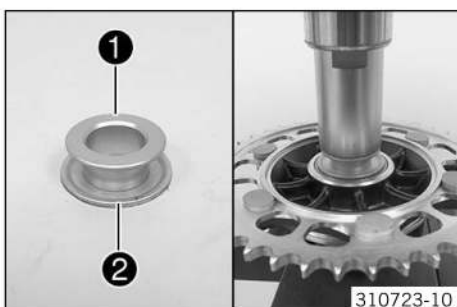

- Press in the distance sleeve ① from the outside all the way to the inside using the shim ②.

## 14.8.14 Opening the chain

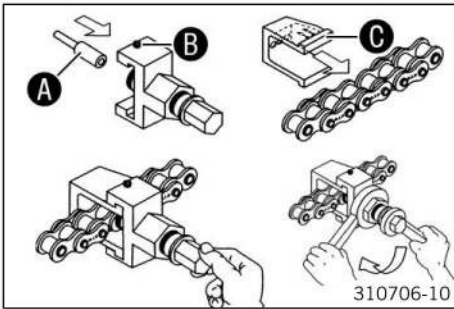

- Mount press drift **A** with the larger diameter in the spindle of the special tool. Turn the spindle counterclockwise.
- Chain rivet tool (60029020000) (📖 p. 347)
- Make the connecting link of the chain accessible. Fret the riveting point.
  - Position the special tool with the press drift on one of the 2 pins of the connecting link of the chain.
    - ✓ Locking screw **B** points upwards.
  - Position retaining clamp **C** of the special tool on the chain from the rear.
    - ✓ Markings **A** and **B** point upwards.
  - Slide retaining clamp **C** of the special tool into the pressing tool.
    - ✓ The arrow of marking **A** points to locking screw **B**.
  - Screw the locking screw hand-tight as far as it will go.
    - ✓ The retaining clamp is fixed.
  - Hold the special tool and screw in the spindle.
    - ✓ The chain pin is pressed out through the retaining clamp drill hole.
  - Unscrew the locking screw and remove the special tool.
  - Repeat the process on the second pin of the chain link.

## 14.8.15 Riveting the chain

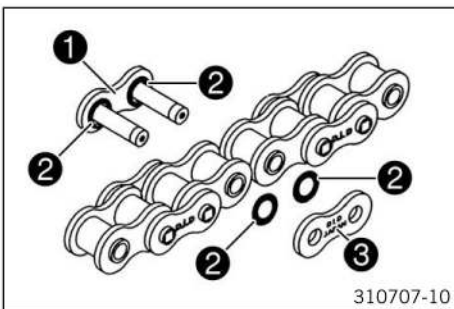

- Grease new connecting link **1** and position an X-ring **2** on each pin.
- Connect the chain ends with a connecting link.
- Position another X-ring **2** on each pin.

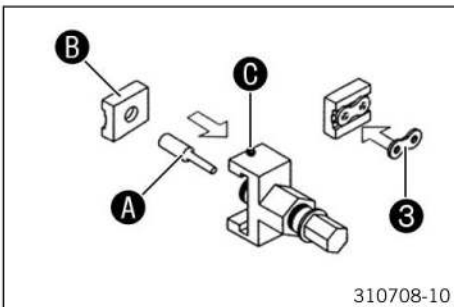

- Mount press drift **A** with the smaller diameter in the spindle of the special tool. Turn the spindle counterclockwise.
- Chain rivet tool (60029020000) (📖 p. 347)
- Position press plate **B** of the special tool on the press drift.
  - Position chain joint plate **3** in the press plate.

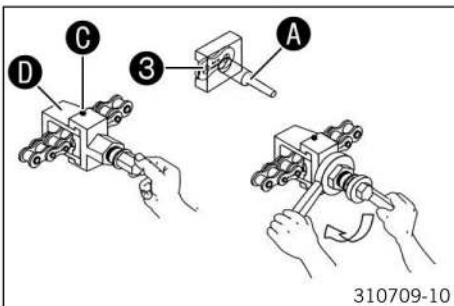

- Position the special tool on the chain.
  - ✓ Locking screw **C** points upwards.
- Position retaining clamp **D** of the special tool on the chain from the rear.
  - ✓ Markings **A** and **B** point upwards.
- Slide retaining clamp **D** of the special tool into the pressing tool.
  - ✓ The arrow of marking **A** points to locking screw **C**.
- Screw the locking screw hand-tight as far as it will go.
  - ✓ The retaining clamp is fixed.
- Hold the special tool and screw in the spindle.
  - ✓ Press drift **A** of the special tool presses against the center of the chain joint plate **3**.
  - ✓ The chain joint plate is pressed on.
- Unscrew the locking screw and remove the special tool.
- Rivet the two pins of the connecting link with special tool.

Chain rivet tool (60029020000) (📖 p. 347)

## 14.8.16 Changing the drivetrain kit

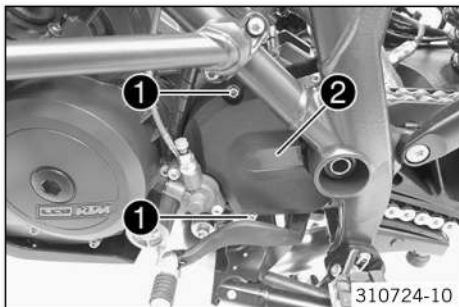

### Main work

- Remove screws 1.
- Take off engine sprocket cover 2.

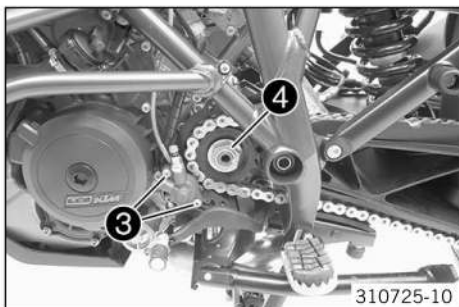

- Remove screws 3.
- Take off the slave cylinder of the clutch and hang it to one side.



### Info

Do not activate the clutch lever while the slave cylinder of the clutch is removed.  
Do not kink the clutch line.

- Remove the spacer with sleeves.
- Bend up the lock washer.
- Have an assistant operate the rear brake.
- Remove nut 4 with the lock washer.
- Remove screw 5.



### Info

Do not misplace the spacer.

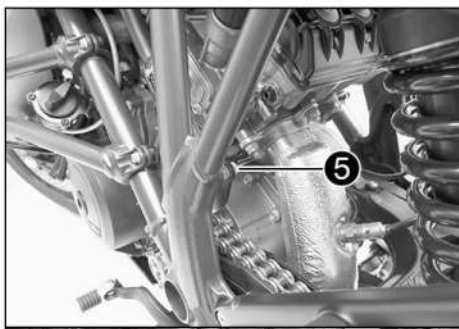

- Remove screw 6.
- Remove the chain securing guide with the spacer.

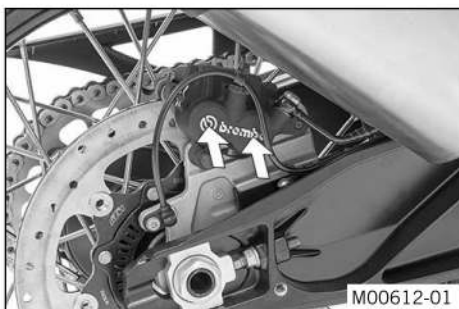
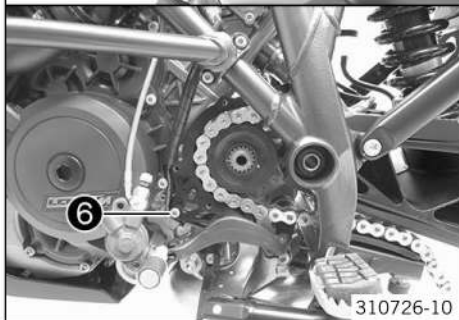

- Press the brake caliper onto the brake disc by hand in order to push back the brake pistons.

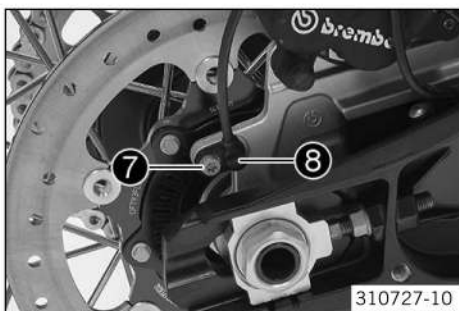

- Remove screw 7 and pull wheel speed sensor 8 out of the hole.

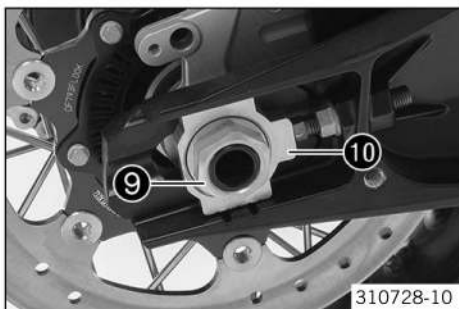

- Remove nut 9. Remove chain adjuster 10.

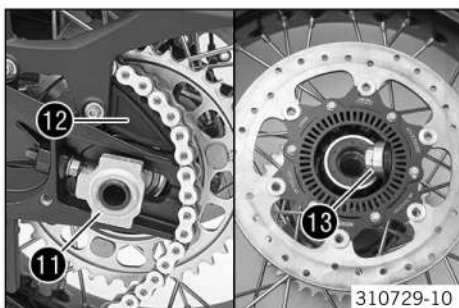

- Withdraw wheel spindle 11 only enough to allow the rear wheel to be pushed forward.
- Push the rear wheel forward as far as possible. Take the chain off of the rear sprocket and place it on chain sprocket guard 12.



**Warning**

**Danger of accidents** Reduced braking effect caused by damaged brake discs.

- Always lay the wheel down in such a way that the brake discs are not damaged.

- Holding the rear wheel, withdraw the wheel spindle. Take the rear wheel out of the swingarm.



**Info**

Do not operate the foot brake when the rear wheel is removed.

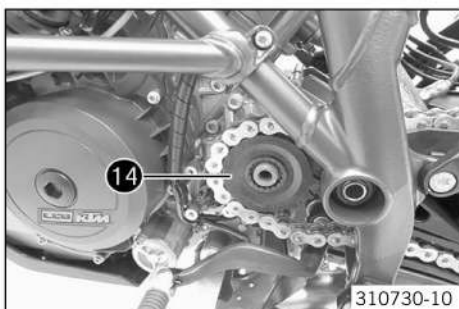

- Remove spacer 13.
- Remove engine sprocket 14.
- Open the chain. (📖 p. 120)
- Mount the new chain.
- Rivet the chain. (📖 p. 120)
- Position engine sprocket 14 in the chain and mount on the countershaft.

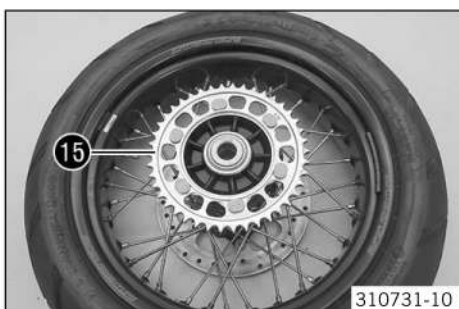

- Remove rear sprocket carrier 15.

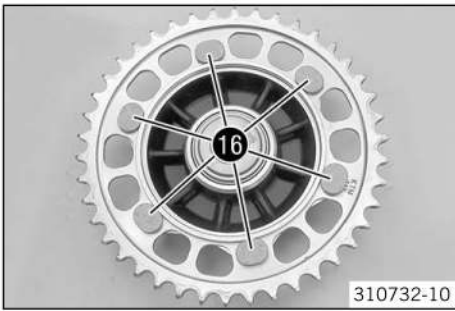

- Fix the rear sprocket carrier in the vise.

**i Info**  
Use soft jaws.

- Remove fittings 16 and take off the rear sprocket.
- Position the new rear sprocket.
- Mount and tighten fittings 16.

Guideline

Nut, rear sprocket screw	M10x1.25	50 Nm (36.9 lbf ft)	Loctite® 243™
--------------------------	----------	------------------------	---------------

- Mount rear sprocket carriers 15.

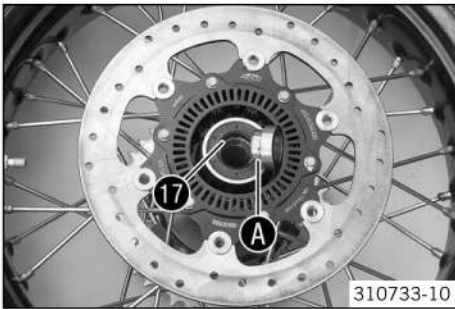
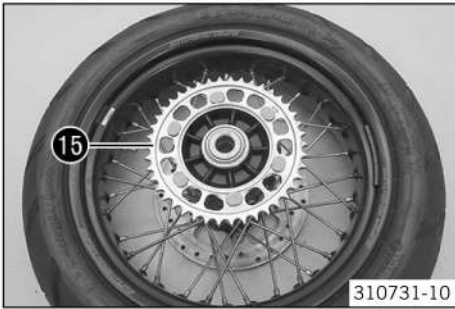

- Check the wheel bearing for damage and wear.
  - » If the wheel bearing is damaged or worn:
    - Change the rear wheel bearing. (📖 p. 109)
- Clean and grease shaft seal ring 17 and contact surface A of the spacer.

Long-life grease (📖 p. 340)

- Clean and grease the thread of the wheel spindle and nut.

Long-life grease (📖 p. 340)

- Install the rubber dampers and rear sprocket carrier on the rear wheel.
- Place the rear wheel in the swingarm and bring the brake disc into contact with the brake caliper.
- Mount wheel spindle 11 but do not push it in all the way.
- Push the rear wheel as far forward as possible and place the chain on the rear sprocket.

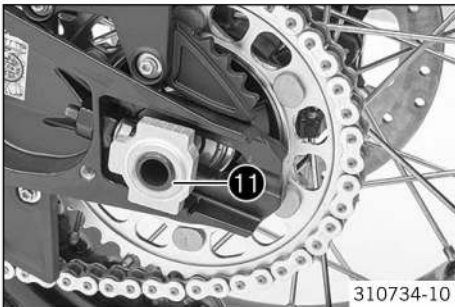

- Push in the wheel spindle all the way and mount chain adjuster 10 and nut 9 but do not tighten yet.

Guideline

Nut, rear wheel spindle	M25x1.5	90 Nm (66.4 lbf ft)	Thread greased
-------------------------	---------	------------------------	----------------

**i Info**  
Mount chain adjusters 10 in the same position.

- Make sure that the chain adjusters are fitted correctly on the adjusting screws.

Guideline

In order for the rear wheel to be correctly aligned, the markings on the left and right chain adjusters must be in the same position relative to reference markings B.

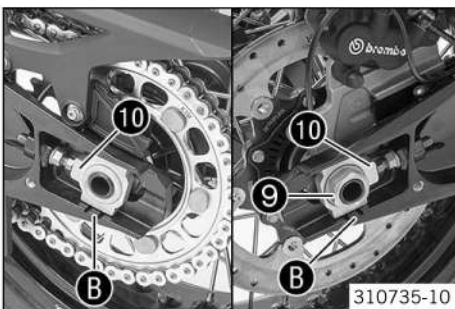

- Tighten nut 9.

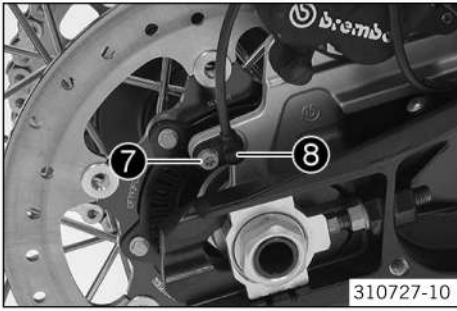

Guideline

Nut, rear wheel spindle	M25x1.5	90 Nm (66.4 lbf ft)	Thread greased
-------------------------	---------	------------------------	----------------

- Position wheel speed sensor **8** in the drill hole.
- Mount and tighten screw **7**.

Guideline

Remaining chassis screws	M6	10 Nm (7.4 lbf ft)
--------------------------	----	--------------------

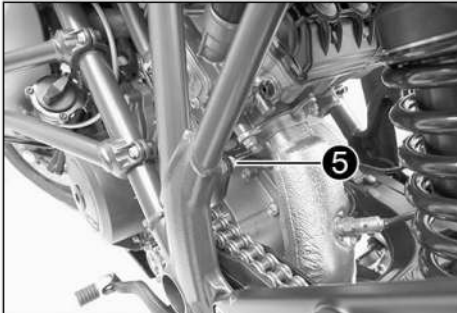

- Position the chain securing guide with the spacer.
- Mount and tighten screw **5** with the spacer.

Guideline

Remaining chassis nuts	M8	25 Nm (18.4 lbf ft)
------------------------	----	------------------------

- Mount and tighten screw **6**.

Guideline

Remaining chassis nuts	M6	10 Nm (7.4 lbf ft)
------------------------	----	--------------------

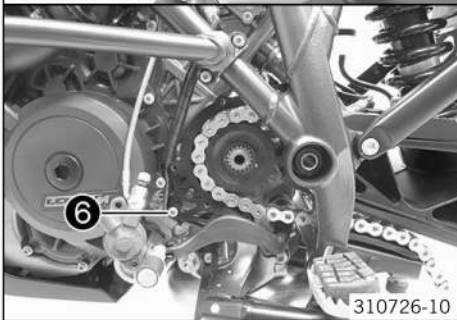

- Have an assistant operate the rear brake.
- Mount nut with lock washer **4** and tighten.

Guideline

Nut of engine sprocket	M20x1.5	100 Nm (73.8 lbf ft)	<b>Loctite® 243™</b>
------------------------	---------	-------------------------	----------------------

- Secure the nut with the lock washer.
- Mount the clutch slave cylinder with spacer and sleeves.
- Mount and tighten screws **3**.

Guideline

Clutch slave cylinder screw	M6	10 Nm (7.4 lbf ft)
-----------------------------	----	--------------------

- Position engine sprocket cover **2**.
- Mount and tighten screws **1**.

Guideline

Remaining chassis screws	M6	10 Nm (7.4 lbf ft)
--------------------------	----	--------------------

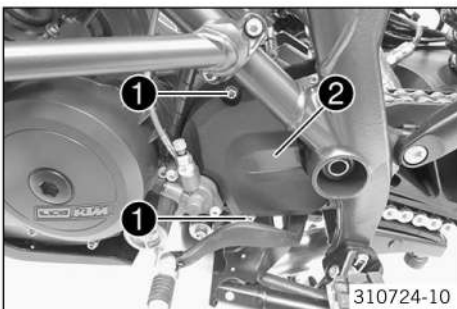

**Finishing work**

- Check the chain tension. (📖 p. 115)
- Remove the vehicle from the center stand. (📖 p. 12)

## 15.1 Removing the battery



### Warning

**Risk of injury** Battery acid and battery gases cause serious chemical burns.

- Keep batteries out of the reach of children.
- Wear suitable protective clothing and safety glasses.
- Avoid contact with battery acid and battery gases.
- Keep sparks or open flames away from the battery.
- Only charge batteries in well-ventilated rooms.
- Rinse the affected area immediately with plenty of water in the event of contact with the skin.
- Rinse eyes with water for at least 15 minutes and consult a doctor immediately if battery acid and battery gases get into the eyes.



### Caution

**Danger of accidents** Electronic components and safety devices will be damaged if the battery is discharged or missing.

- Never operate the vehicle with a discharged battery or without a battery.

### Preparatory work

- Switch off all power consumers and switch off the engine.
- Remove the passenger seat. (📖 p. 72)
- Remove the front rider's seat. (📖 p. 71)

### Main work

- Pull locking mechanism ① in the direction of the arrow.
- Fold open cover ②.

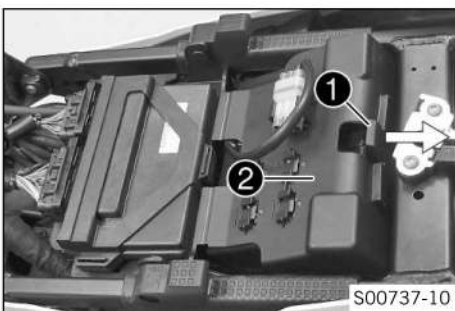

- Disconnect negative cable ③ from the battery.
- Disconnect positive cable ④ from the battery.
- Take the battery and battery case ⑤ out of the battery compartment.

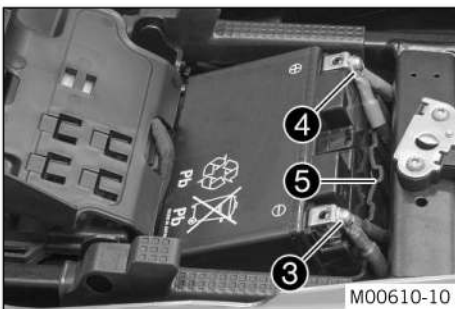

## 15.2 Installing the battery



### Warning

**Risk of injury** Battery acid and battery gases cause serious chemical burns.

- Keep batteries out of the reach of children.
- Wear suitable protective clothing and safety glasses.
- Avoid contact with battery acid and battery gases.
- Keep sparks or open flames away from the battery.
- Only charge batteries in well-ventilated rooms.
- Rinse the affected area immediately with plenty of water in the event of contact with the skin.
- Rinse eyes with water for at least 15 minutes and consult a doctor immediately if battery acid and battery gases get into the eyes.



### Caution

**Danger of accidents** Electronic components and safety devices will be damaged if the battery is discharged or missing.

- Never operate the vehicle with a discharged battery or without a battery.

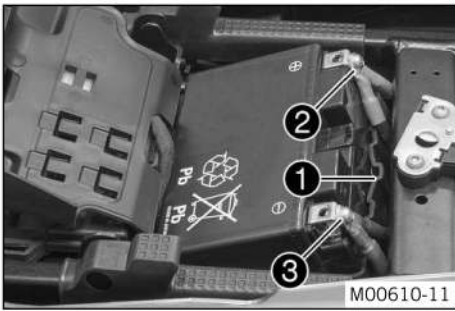

**Main work**

- Position the battery in battery case ①.

Guideline

The even side of the battery case must be opposite the poles.

- Position the battery and battery case in the battery compartment.
- Position the positive cable ② and mount and tighten the screw.

Guideline

Screw, battery terminal	M6	4.5 Nm (3.32 lbf ft)
-------------------------	----	-------------------------

- Position the negative cable ③ and mount and tighten the screw.

Guideline

Screw, battery terminal	M6	4.5 Nm (3.32 lbf ft)
-------------------------	----	-------------------------

- Close the cover ④ and push down slightly.
- ✓ The cover engages with an audible click.

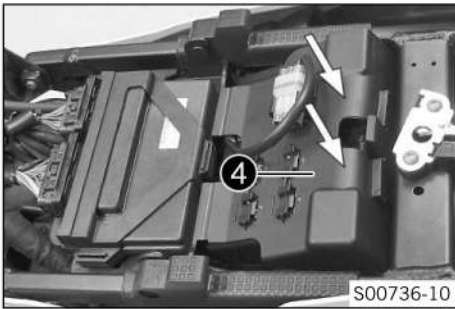

**Finishing work**

- Mount the front rider's seat. (📖 p. 71)
- Mount the passenger seat. (📖 p. 72)
- Set the time and date.

**15.3 Disconnecting the negative (minus) cable of the battery**

**Warning**

**Risk of injury** Battery acid and battery gases cause serious chemical burns.

- Keep batteries out of the reach of children.
- Wear suitable protective clothing and safety glasses.
- Avoid contact with battery acid and battery gases.
- Keep sparks or open flames away from the battery.
- Only charge batteries in well-ventilated rooms.
- Rinse the affected area immediately with plenty of water in the event of contact with the skin.
- Rinse eyes with water for at least 15 minutes and consult a doctor immediately if battery acid and battery gases get into the eyes.

**Caution**

**Danger of accidents** Electronic components and safety devices will be damaged if the battery is discharged or missing.

- Never operate the vehicle with a discharged battery or without a battery.

**Preparatory work**

- Remove the passenger seat. (📖 p. 72)
- Remove the front rider's seat. (📖 p. 71)

**Main work**

- Pull locking mechanism ① in the direction of the arrow.
- Fold open cover ②.

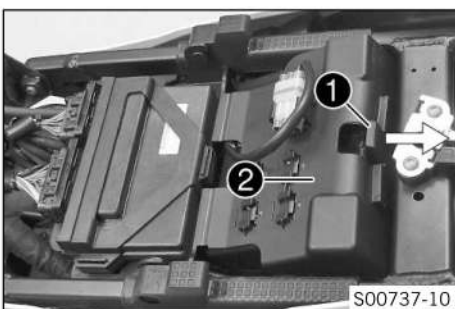



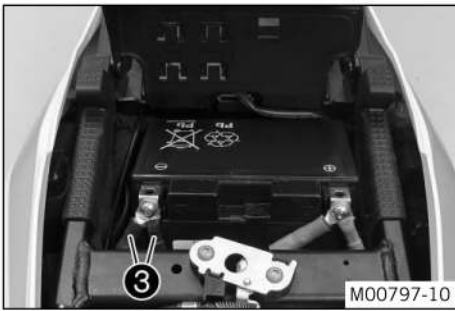

- Disconnect negative cable ③ of the battery.

## 15.4 Connecting the negative cable of the battery

- Warning**  
**Risk of injury** Battery acid and battery gases cause serious chemical burns.
- Keep batteries out of the reach of children.
  - Wear suitable protective clothing and safety glasses.
  - Avoid contact with battery acid and battery gases.
  - Keep sparks or open flames away from the battery.
  - Only charge batteries in well-ventilated rooms.
  - Rinse the affected area immediately with plenty of water in the event of contact with the skin.
  - Rinse eyes with water for at least 15 minutes and consult a doctor immediately if battery acid and battery gases get into the eyes.

- Caution**  
**Danger of accidents** Electronic components and safety devices will be damaged if the battery is discharged or missing.
- Never operate the vehicle with a discharged battery or without a battery.



- Main work**
- Position the negative cable ① and mount and tighten the screw.

Guideline

Screw, battery terminal	M6	4.5 Nm (3.32 lbf ft)
-------------------------	----	-------------------------

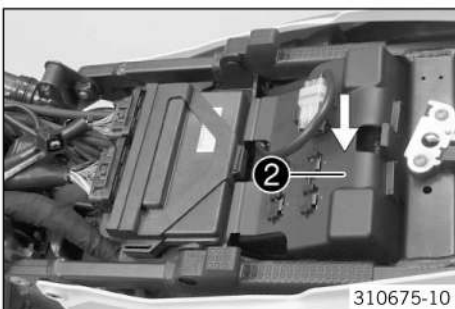

- Close the cover ② and push down slightly.  
 ✓ The cover engages with an audible click.

- Finishing work**
- Mount the front rider's seat. (📖 p. 71)
  - Mount the passenger seat. (📖 p. 72)
  - Set the time and date.

## 15.5 Recharging the battery

**Warning**  
**Risk of injury** Battery acid and battery gases cause serious chemical burns.

- Keep batteries out of the reach of children.
- Wear suitable protective clothing and safety glasses.
- Avoid contact with battery acid and battery gases.
- Keep sparks or open flames away from the battery.
- Only charge batteries in well-ventilated rooms.
- Rinse the affected area immediately with plenty of water in the event of contact with the skin.
- Rinse eyes with water for at least 15 minutes and consult a doctor immediately if battery acid and battery gases get into the eyes.

**Warning**  
**Environmental hazard** Batteries contain environmentally-hazardous materials.

- Do not dispose of batteries as household waste.
- Dispose of batteries at a collection point for used batteries.

**Warning**  
**Environmental hazard** Hazardous substances cause environmental damage.

- Dispose of oils, grease, filters, fuel, cleaning agents, brake fluid, etc., correctly and in compliance with the applicable regulations.

**Info**  
 Even when there is no load on the battery, it discharges steadily.  
 The charging level and the method of charging are very important for the service life of the battery.  
 Rapid recharging with a high charging current shortens the service life of the battery.  
 If the charging current, charging voltage, and charging time are exceeded, the battery will be destroyed.  
 If the battery is depleted from starting the vehicle repeatedly, the battery must be charged immediately.  
 If the battery is left in a discharged state for an extended period, it will become over-discharged and sulfated, destroying the battery.  
 The battery is maintenance-free, i.e., the acid level does not have to be checked.

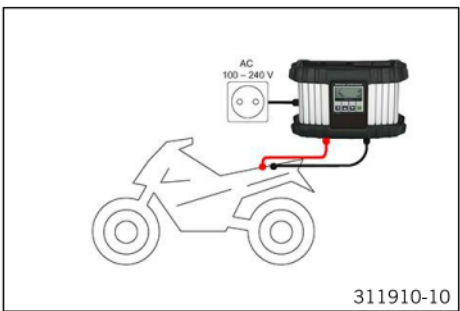

- Preparatory work**
- Switch off all power consumers and switch off the engine.
  - Remove the passenger seat. (📖 p. 72)
  - Remove the front rider's seat. (📖 p. 71)
  - Remove the battery. (📖 p. 125)

**Main work**  
 - Connect the battery charger to the battery. Set the battery charger.

**Alternative 1**  
 Battery charger **XCharge-professional** EU (00029095050) (📖 p. 342)

**Alternative 2**  
 Battery charger **XCharge-professional** US (00029095051) (📖 p. 342)

**Alternative 3**  
 Battery charger **XCharge-professional** GB (00029095052) (📖 p. 343)

**Alternative 4**  
 Battery charger **XCharge-professional** CH (00029095053) (📖 p. 343)

**Info**  
 Follow the instructions of the charger and the manual.

- Disconnect the battery charger after charging the battery.
- Guideline

The charging current, charging voltage, and charging time must not be exceeded.	
Charge the battery regularly when the motorcycle is not in use	3 months

### Finishing work

- Install the battery. (📖 p. 125)
- Mount the front rider's seat. (📖 p. 71)
- Mount the passenger seat. (📖 p. 72)
- Set the time and date.

## 15.6 Changing the main fuse

**Warning**  
**Fire hazard** Incorrect fuses overload the electrical system.

- Only use fuses with the required ampere value.
- Do not bypass or repair fuses.

### Preparatory work

- Switch off all power consumers and switch off the engine.
- Remove the passenger seat. (📖 p. 72)
- Remove the front rider's seat. (📖 p. 71)

### Main work

- Remove screws **1**.
- Raise rear fairing **2** slightly.

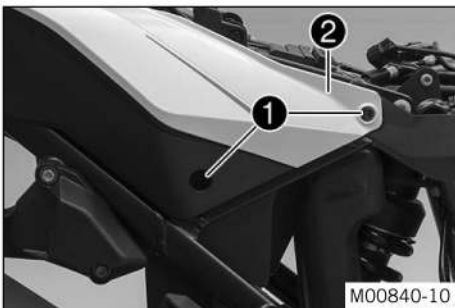

- Remove protection caps **3**.

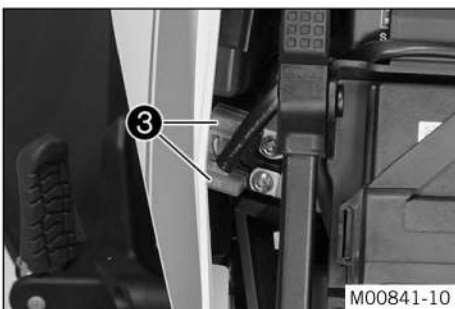

- Remove the faulty main fuse **4**.

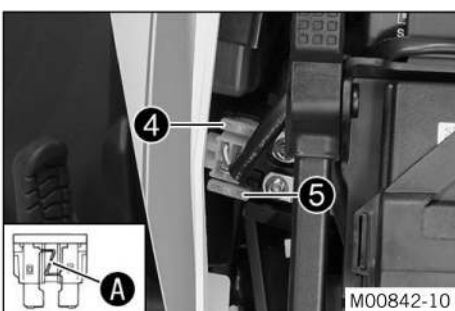

**i Info**  
 A defective fuse is indicated by a burned-out fuse wire **A**.  
 A spare fuse **5** is located in the starter relay.  
 The main fuse protects all power consumers of the vehicle.

- Install a new main fuse.

Fuse (58011109130) (📖 p. 301)

- Check that the electrical equipment is functioning properly.
- Mount the protection caps.

**i Tip**  
 Insert a new spare fuse into the starter relay to have it available when needed.

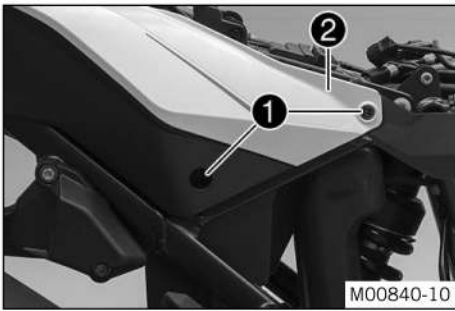

- Position rear fairing ②.
- ✓ Heat protector is correctly positioned.
- Mount and tighten screws ①.

Guideline

Screw, cover part	M5	3.5 Nm (2.58 lbf ft)
-------------------	----	-------------------------

**Finishing work**

- Mount the front rider's seat. (📖 p. 71)
- Mount the passenger seat. (📖 p. 72)
- Set the time and date.

## 15.7 Changing the fuses in the fuse box

**Warning**  
**Fire hazard** Incorrect fuses overload the electrical system.

- Only use fuses with the required ampere value.
- Do not bypass or repair fuses.

**Info**  
 The fuse box containing the fuses of individual power consumers is located under the seat.

**Preparatory work**

- Switch off all power consumers and switch off the engine.
- Remove the passenger seat. (📖 p. 72)
- Remove the front rider's seat. (📖 p. 71)

**Main work**  
**(Super Adventure EU/FR/AU/JP)**

- Open fuse box cover ①.

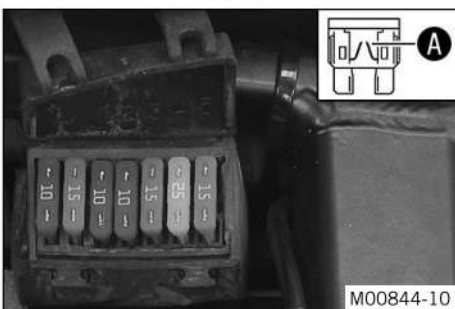
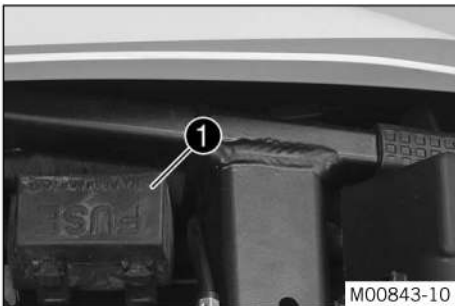

- Check the fuses.

**Info**  
 A defective fuse is indicated by a burned-out fuse wire ①.

- Remove the defective fuse.

Guideline

Fuse <b>res</b> - 10 A - spare fuse
Fuse <b>res</b> - 15 A - spare fuse
Fuse <b>1</b> - 10 A - power supply for control units and components
Fuse <b>2</b> - 10 A - socket (ACC1)
Fuse <b>3</b> - 15 A - ABS hydraulic unit
Fuse <b>4</b> - 25 A - ABS return pump
Fuse <b>5</b> - 15 A - semi-active suspension

- Use spare fuses with the correct rating only.

Fuse (58011109110) (📖 p. 301)
Fuse (58011109115) (📖 p. 301)
Fuse (58011109125) (📖 p. 301)



S00738-10

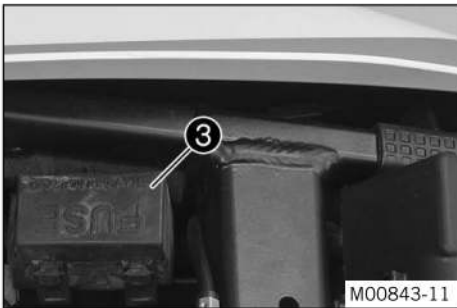

M00843-11

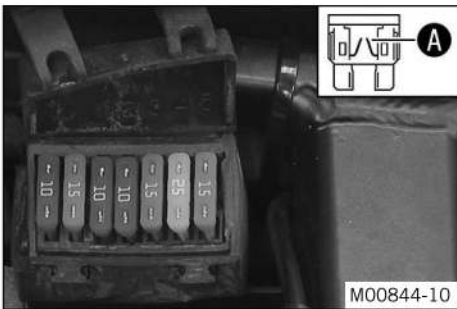

M00844-10

**i Tip**

Insert a spare fuse so that it is available if needed.

- Check that the power consumer is functioning properly.
- Close the fuse box cover.

**(Super Adventure US/CN)**

- Detach active carbon filter **1**.
- Detach active carbon filter **2**.

**i Info**

Pay attention to the hoses.

- Open fuse box cover **3**.

- Check the fuses.

**i Info**

A defective fuse is indicated by a burned-out fuse wire **A**.

- Remove the defective fuse.

**Guideline**

Fuse <b>res</b> - 10 A - spare fuse
Fuse <b>res</b> - 15 A - spare fuse
Fuse <b>1</b> - 10 A - power supply for control units and components
Fuse <b>2</b> - 10 A - socket (ACC1)
Fuse <b>3</b> - 15 A - ABS hydraulic unit
Fuse <b>4</b> - 25 A - ABS return pump
Fuse <b>5</b> - 15 A - semi-active suspension

- Use spare fuses with the correct rating only.

Fuse (58011109110) (📖 p. 301)
Fuse (58011109115) (📖 p. 301)
Fuse (58011109125) (📖 p. 301)

**i Tip**

Insert a new spare fuse so that it is available when needed.

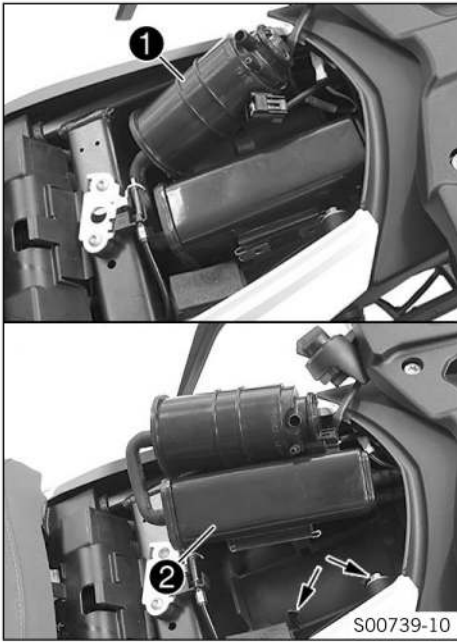

- Check that the power consumer is functioning properly.
- Close the fuse box cover.
- Position activated charcoal filter **2**.

**i Info**  
Pay attention to the holding lugs.

- Position activated charcoal filter **1**.

**Finishing work**

- Mount the front rider's seat. (📖 p. 71)
- Mount the passenger seat. (📖 p. 72)

## 15.8 Checking the charging voltage

**Condition**

The battery must be fully functional and completely charged.

**Preparatory work**

- Remove the passenger seat. (📖 p. 72)
- Remove the front rider's seat. (📖 p. 71)

**Main work**

- Pull locking mechanism **1** in the direction of the arrow.
- Fold open cover **2**.
- Start the motorcycle to check the function. (📖 p. 13)

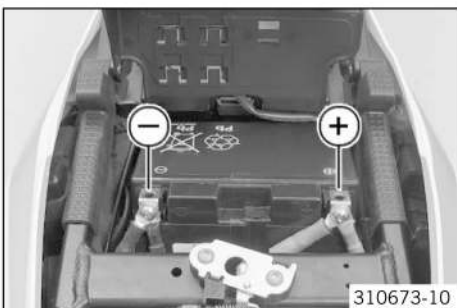
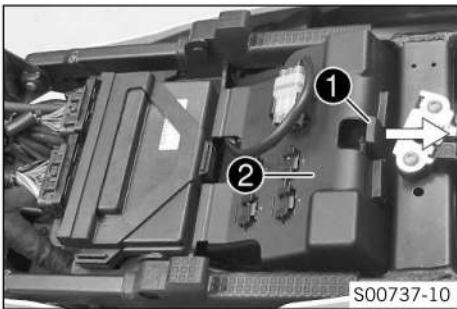

- **V** Measure the voltage between the specified points.  
Measuring point **Plus (+)** – Measuring point **Ground(-)**

Charging voltage	
5,000 rpm	13.5... 15.0 V

- » If the displayed value is greater than the specified value:
  - Change the voltage regulator.

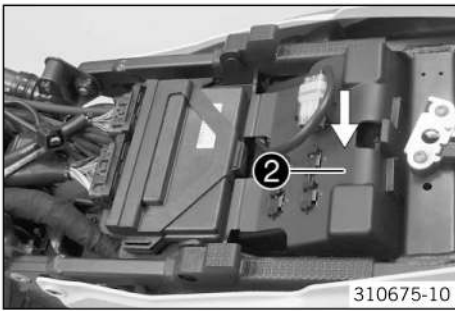

- Close cover ② and push down slightly.
- ✓ The cover engages with an audible click.

**Finishing work**

- Mount the front rider's seat. (📖 p. 71)
- Mount the passenger seat. (📖 p. 72)

**15.9 Checking the open-circuit current**

**Preparatory work**

- Remove the passenger seat. (📖 p. 72)
- Remove the front rider's seat. (📖 p. 71)

**Main work**

- Pull locking mechanism ① in the direction of the arrow.
- Fold open cover ②.

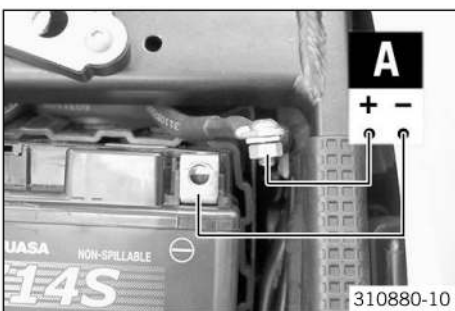
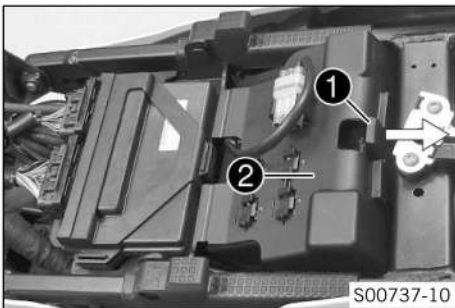

- Disconnect the negative cable of the battery.
- Connect the negative cable of the battery with an appropriate fitting.
- Measure the current between battery ground (-) and the negative cable.



**Info**

The value of the open-circuit current only applies to vehicles in their original state without additional power consumers.  
After switching off the ignition, wait 1 minute until the measurement.

Maximum open-circuit current	< 1.0 mA
------------------------------	----------

- » If the measured value is greater than the specified value:
  - Disconnect the voltage regulator from the wiring harness and perform the measurement again.

- Close cover ② and push down slightly.
- ✓ The cover engages with an audible click.

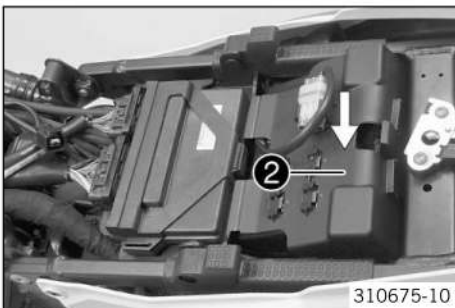

**Finishing work**

- Mount the front rider's seat. (📖 p. 71)
- Mount the passenger seat. (📖 p. 72)

## 16.1 Checking the front brake linings

**Warning**  
**Danger of accidents** Worn-out brake linings reduce the braking effect.

- Ensure that worn-out brake linings are replaced immediately.

**Warning**  
**Danger of accidents** Damaged brake discs reduce the braking effect.  
 If the brake linings are not changed in time, the brake lining carriers grind against the brake disc. As a consequence, the braking effect is greatly reduced and the brake discs are destroyed.

- Check the brake linings regularly.

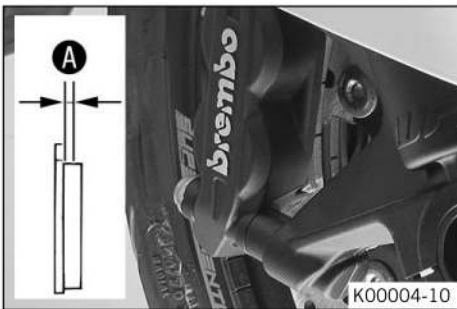

- Check all brake linings on both brake calipers to ensure they have minimum thickness **A**.

Minimum thickness	≥ 1 mm (≥ 0.04 in)
-------------------	--------------------

- » If the minimum thickness is less than specified:
  - Change the front brake linings. (📖 p. 134)
- Check all brake linings on both brake calipers for damage and cracking.
  - » If there is damage or cracking:
    - Change the front brake linings. (📖 p. 134)

## 16.2 Changing the front brake linings

**Warning**  
**Skin irritation** Brake fluid causes skin irritation.

- Keep brake fluid out of the reach of children.
- Wear suitable protective clothing and safety glasses.
- Do not allow brake fluid to come into contact with the skin, the eyes or clothing.
- Consult a doctor immediately if brake fluid has been swallowed.
- Rinse the affected area with plenty of water in the event of contact with the skin.
- Rinse eyes thoroughly with water immediately and consult a doctor if brake fluid comes into contact with the eyes.
- If brake fluid spills on to your clothing, change the clothing.

**Warning**  
**Danger of accidents** Old brake fluid reduces the braking effect.

- Make sure that brake fluid for the front and rear brake is changed in accordance with the service schedule.

**Warning**  
**Danger of accidents** Oil or grease on the brake discs reduces the braking effect.

- Always keep the brake discs free of oil and grease.
- Clean the brake discs with brake cleaner when necessary.

**Warning**  
**Danger of accidents** Brake linings which have not been approved alter the braking efficiency.  
 Not all brake linings are tested and approved for KTM motorcycles. The structure and friction coefficient of the brake linings, and thus their brake power, may vary greatly from that of original brake linings.  
 If brake linings are used that differ from the original equipment, compliance with the original homologation is not guaranteed. In this case, the vehicle no longer corresponds to its condition at delivery and the warranty shall be void.

- Only use brake linings approved and recommended by KTM.

**Warning**  
**Environmental hazard** Hazardous substances cause environmental damage.

- Dispose of oils, grease, filters, fuel, cleaning agents, brake fluid, etc., correctly and in compliance with the applicable regulations.



**i Info**

Never use DOT 5 brake fluid! It is silicone-based and purple in color. Oil seals and brake lines are not designed for DOT 5 brake fluid.

Avoid contact between brake fluid and painted parts. Brake fluid attacks paint!

Use only clean brake fluid from a sealed container.

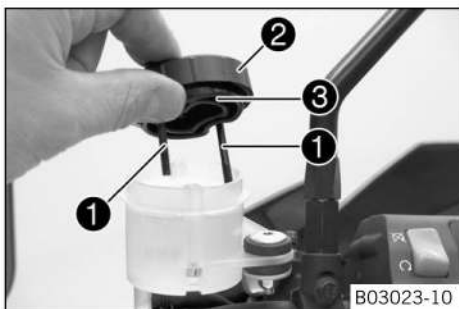

- Move the brake fluid reservoir mounted on the handlebar to a horizontal position.
- Remove screws ①.
- Remove cover ② with membrane ③.

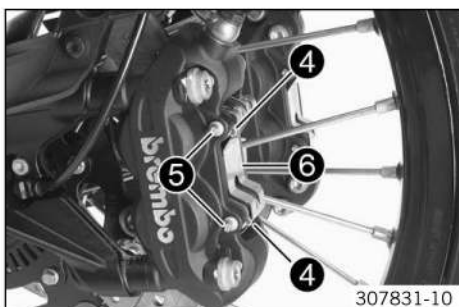

- Press the brake piston back into the basic position and ensure that brake fluid does not flow out of the brake fluid reservoir, sucking it away if necessary.
- Remove cotter pins ④ and pull out pin ⑤.
- Remove retaining bracket ⑥.

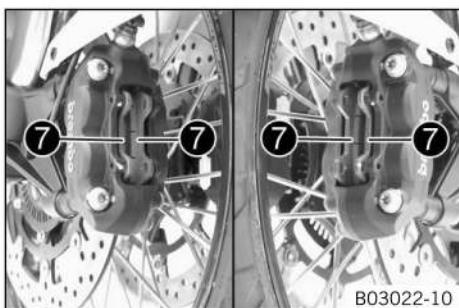

- Remove brake linings ⑦.
- Clean the brake caliper.
- Mount new brake linings ⑦.

**i Info**

Always change the brake linings in pairs and on both sides.

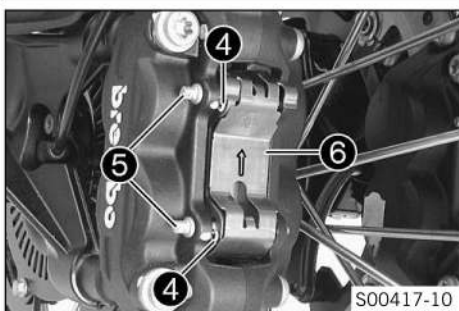

- Position retaining bracket ⑥.
- ✓ The arrow on the retaining bracket points in the direction of motion.
- Mount pin ⑤ and cotter pins ④.
- Repeat the operation on the opposite side.

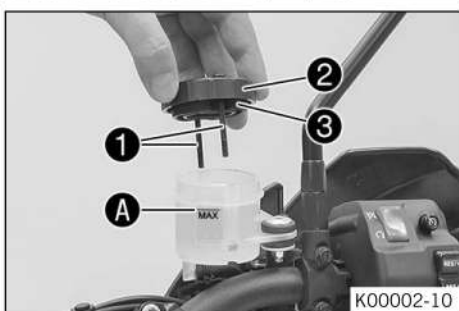

- Operate the hand brake lever repeatedly until the brake linings are in contact with the brake disc and there is a pressure point.
- Correct the brake fluid to **MAX** marking A.

Brake fluid DOT 4 / DOT 5.1 (📖 p. 338)

- Position cover ② with membrane ③.

**i Info**

Clean up overflowed or spilt brake fluid immediately with water.

- Mount and tighten screws ①.

## 16.3 Checking the brake fluid level of the front brake

**Warning**

**Danger of accidents** An insufficient brake fluid level will cause the brake system to fail.

If the brake fluid level drops below the **MIN** marking, the brake system is leaking or the brake linings are worn down.

- Check the brake system and do not continue riding until the problem is eliminated.

**Warning**

**Danger of accidents** Old brake fluid reduces the braking effect.

- Make sure that brake fluid for the front and rear brake is changed in accordance with the service schedule.

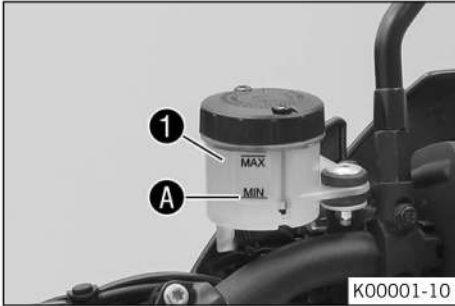

- Move the brake fluid reservoir mounted on the handlebar to a horizontal position.
- Check the brake fluid level in the brake fluid reservoir ①.
  - » If the brake fluid has dropped below marking **MIN A**:
    - Add front brake fluid. (📖 p. 136)

## 16.4 Adding front brake fluid

**Warning**

**Danger of accidents** An insufficient brake fluid level will cause the brake system to fail.

If the brake fluid level drops below the **MIN** marking, the brake system is leaking or the brake linings are worn down.

- Check the brake system and do not continue riding until the problem is eliminated.

**Warning**

**Skin irritation** Brake fluid causes skin irritation.

- Keep brake fluid out of the reach of children.
- Wear suitable protective clothing and safety glasses.
- Do not allow brake fluid to come into contact with the skin, the eyes or clothing.
- Consult a doctor immediately if brake fluid has been swallowed.
- Rinse the affected area with plenty of water in the event of contact with the skin.
- Rinse eyes thoroughly with water immediately and consult a doctor if brake fluid comes into contact with the eyes.
- If brake fluid spills on to your clothing, change the clothing.

**Warning**

**Danger of accidents** Old brake fluid reduces the braking effect.

- Make sure that brake fluid for the front and rear brake is changed in accordance with the service schedule.

**Warning**

**Environmental hazard** Hazardous substances cause environmental damage.

- Dispose of oils, grease, filters, fuel, cleaning agents, brake fluid, etc., correctly and in compliance with the applicable regulations.

**Info**

Never use DOT 5 brake fluid. It is silicone-based and purple in color. Oil seals and brake lines are not designed for DOT 5 brake fluid.

Avoid contact between brake fluid and painted parts. Brake fluid attacks paint.

Only use clean brake fluid from a sealed container.

**Preparatory work**

- Check the front brake linings. (📖 p. 134)

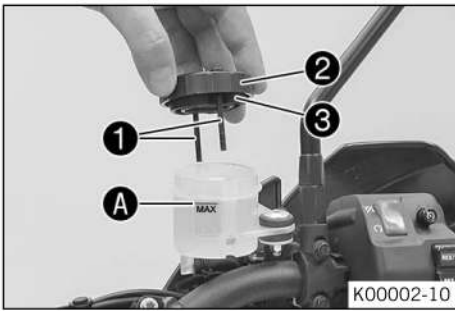

**Main work**

- Move the brake fluid reservoir mounted on the handlebar to a horizontal position.
- Remove screws ①.
- Remove cover ② with membrane ③.
- Add brake fluid up to **MAX** marking **A**.

Brake fluid DOT 4 / DOT 5.1 (📖 p. 338)

- Position cover ② with membrane ③.
- Mount and tighten screws ①.

**i Info**

Clean up overflowed or spilled brake fluid immediately with water.

**16.5 Changing the front brake fluid**

**⚠ Warning**

**Skin irritation** Brake fluid causes skin irritation.

- Keep brake fluid out of the reach of children.
- Wear suitable protective clothing and safety glasses.
- Do not allow brake fluid to come into contact with the skin, the eyes or clothing.
- Consult a doctor immediately if brake fluid has been swallowed.
- Rinse the affected area with plenty of water in the event of contact with the skin.
- Rinse eyes thoroughly with water immediately and consult a doctor if brake fluid comes into contact with the eyes.
- If brake fluid spills on to your clothing, change the clothing.

**🌿 Warning**

**Environmental hazard** Hazardous substances cause environmental damage.

- Dispose of oils, grease, filters, fuel, cleaning agents, brake fluid, etc., correctly and in compliance with the applicable regulations.

**i Info**

Avoid contact between brake fluid and painted parts. Brake fluid attacks paint!  
Use only clean brake fluid from a sealed container.

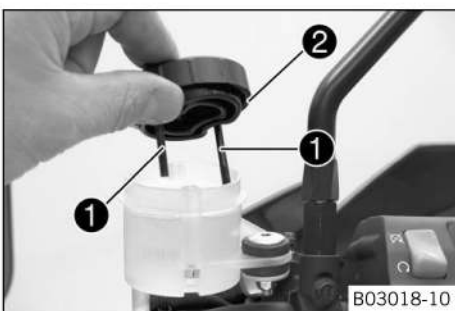

- Move the brake fluid reservoir mounted on the handlebar to a horizontal position.
- Cover the painted parts.
- Remove screws ①.
- Remove cover ② with the membrane.
- Extract the old brake fluid from the brake fluid reservoir with a syringe and add fresh brake fluid.

Bleed syringe (50329050000) (📖 p. 344)

Brake fluid DOT 4 / DOT 5.1 (📖 p. 338)

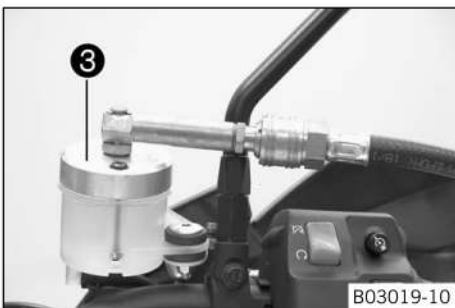

- Mount the corresponding bleeder cover ③ from the special tool set.

Bleeder cover (00029013002) (📖 p. 342)

- Connect the bleeder device.

Bleeding device (00029013100) (📖 p. 342)

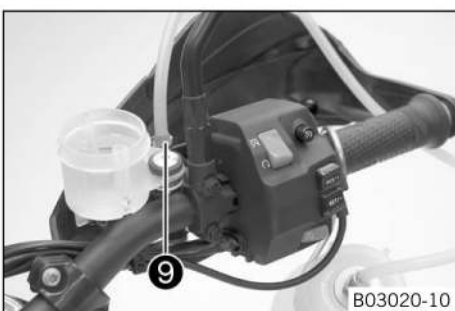
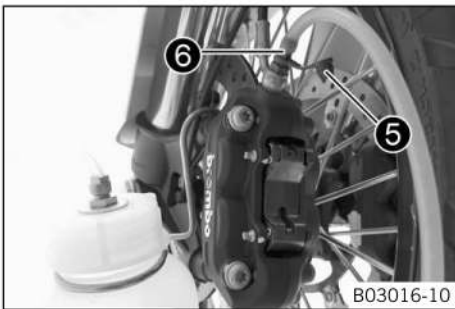
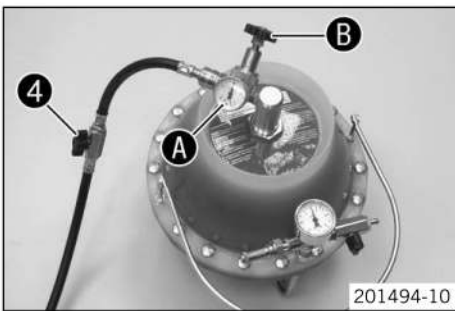

- Open shut-off valve **4**.

**i Info**  
Follow the operating instructions of the bleeding device.

- Ensure that the filling pressure is set on pressure gauge **A**. Adjust the filling pressure on pressure regulator **B** if necessary.

Guideline

Filling pressure	2... 2.5 bar (29... 36 psi)
------------------	-----------------------------

- Pull off protection cap **5** of the bleeder screw of the left brake caliper. Connect the hose of the bleeder bottle.

Bleeding device (00029013100) (p. 342)
--

- Open bleeder screw **6** by approx. one-half turn.

**i Info**  
Drain until the fresh brake fluid emerges from the hose of the bleeder bottle without bubbles.

- Tighten the bleeder screw. Remove the hose of the bleeder bottle. Mount the protection cap.

- Pull off protection cap **7** of the bleeder screw of the right brake caliper. Connect the hose of the bleeder bottle.

Bleeding device (00029013100) (p. 342)
--

- Open bleeder screw **8** by approx. one-half turn.

**i Info**  
Drain until the fresh brake fluid emerges from the hose of the bleeder bottle without bubbles.

- Tighten the bleeder screw.

- Close shut-off valve **4**.

- Open the bleeder screw again until brake fluid stops emerging.

✓ This prevents overfilling of the brake fluid reservoir.

- Tighten the bleeder screw. Remove the hose of the bleeder bottle. Mount the protection cap.

- Lock the bleeding device. Remove the bleeder cover.

- Remove the protection cap of the hand brake cylinder bleeder screw. Connect the hose of the bleeder bottle.

- Open bleeder screw **9** by approx. one-half turn. Operate the hand brake lever repeatedly until fresh brake fluid emerges from the hose of the bleeder bottle without bubbles. Tighten the bleeder screw.

- Remove the hose of the bleeder bottle. Mount the protection cap.

- Correct the brake fluid to the **MAX** marking.

Brake fluid DOT 4 / DOT 5.1 (p. 338)
--------------------------------------

- Position the cover with the membrane. Mount and tighten the screws.

**i Info**  
Clean up overflowed or spilled brake fluid immediately with water.

- Check the hand brake lever for a firm pressure point.

## 16.6 Adjusting the basic position of the hand brake lever



- Adjust the basic position of the hand brake lever to your hand size by turning adjusting wheel ❶.

**i Info**

Push the hand brake lever forward and turn the adjusting wheel. Do not make any adjustments while riding.

## 16.7 Checking the rear brake linings

**Warning**  
**Danger of accidents** Worn-out brake linings reduce the braking effect.  
 - Ensure that worn-out brake linings are replaced immediately.

**Warning**  
**Danger of accidents** Damaged brake discs reduce the braking effect.  
 If the brake linings are not changed in time, the brake lining carriers grind against the brake disc. As a consequence, the braking effect is greatly reduced and the brake discs are destroyed.  
 - Check the brake linings regularly.

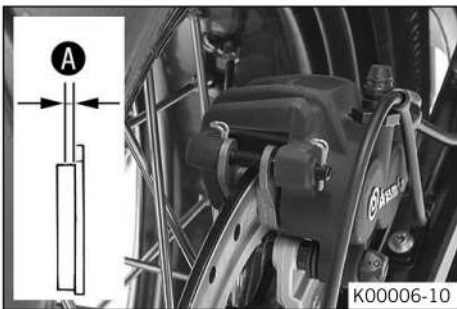

- Check the brake linings for minimum thickness ❶.

Minimum thickness ❶	≥ 1 mm (≥ 0.04 in)
---------------------	--------------------

- » If the minimum thickness is less than specified:
  - Change the rear brake linings. (📖 p. 139)
- Check the brake linings for damage and cracking.
  - » If there is wear or tearing:
    - Change the rear brake linings. (📖 p. 139)

## 16.8 Changing the rear brake linings

**Warning**  
**Skin irritation** Brake fluid causes skin irritation.  
 - Keep brake fluid out of the reach of children.  
 - Wear suitable protective clothing and safety glasses.  
 - Do not allow brake fluid to come into contact with the skin, the eyes or clothing.  
 - Consult a doctor immediately if brake fluid has been swallowed.  
 - Rinse the affected area with plenty of water in the event of contact with the skin.  
 - Rinse eyes thoroughly with water immediately and consult a doctor if brake fluid comes into contact with the eyes.  
 - If brake fluid spills on to your clothing, change the clothing.

**Warning**  
**Danger of accidents** Old brake fluid reduces the braking effect.  
 - Make sure that brake fluid for the front and rear brake is changed in accordance with the service schedule.

**Warning**  
**Danger of accidents** Oil or grease on the brake discs reduces the braking effect.  
 - Always keep the brake discs free of oil and grease.  
 - Clean the brake discs with brake cleaner when necessary.



**Warning**

**Danger of accidents** Brake linings which have not been approved alter the braking efficiency.

Not all brake linings are tested and approved for KTM motorcycles. The structure and friction coefficient of the brake linings, and thus their brake power, may vary greatly from that of original brake linings. If brake linings are used that differ from the original equipment, compliance with the original homologation is not guaranteed. In this case, the vehicle no longer corresponds to its condition at delivery and the warranty shall be void.

- Only use brake linings approved and recommended by KTM.



**Warning**

**Environmental hazard** Hazardous substances cause environmental damage.

- Dispose of oils, grease, filters, fuel, cleaning agents, brake fluid, etc., correctly and in compliance with the applicable regulations.



**Info**

Never use DOT 5 brake fluid! It is silicone-based and purple in color. Oil seals and brake lines are not designed for DOT 5 brake fluid.

Avoid contact between brake fluid and painted parts. Brake fluid attacks paint!

Use only clean brake fluid from a sealed container.

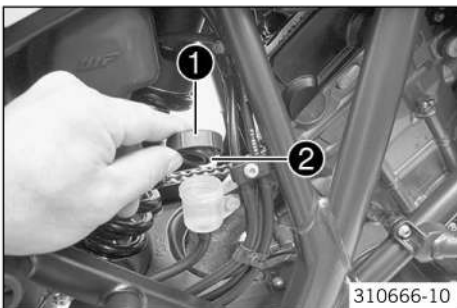

310666-10

- Stand the vehicle upright.
- Remove screw cap **1** with membrane **2**.
- Press the brake caliper onto the brake disc by hand in order to push back the brake piston. Ensure that brake fluid does not overflow from the brake fluid reservoir, using suction to remove it if it does.



**Info**

Make sure when pushing back the brake piston that you do not press the brake caliper against the spokes.

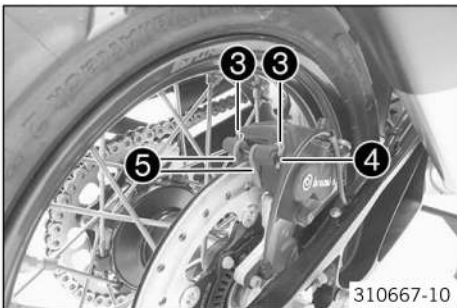

310667-10

- Remove cotter pin **3**.
- Remove pin **4** and brake linings **5**.
- Clean the brake caliper and brake caliper support.

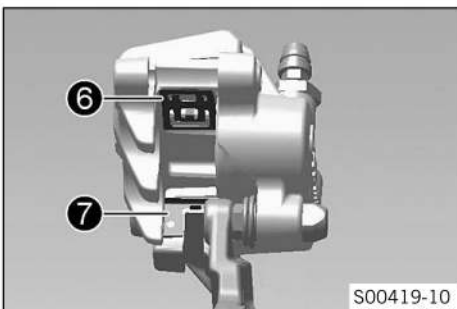

S00419-10

- Check that leaf spring **6** and sliding plate **7** in the brake caliper are seated correctly.

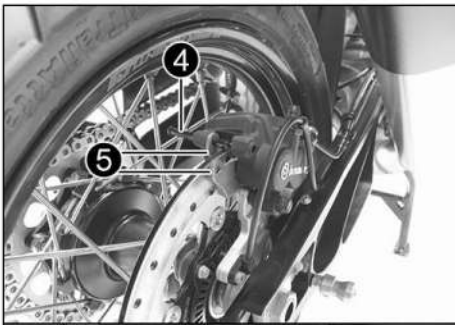

- Position brake linings ⑤.
- Mount pin ④ and cotter pin ③.

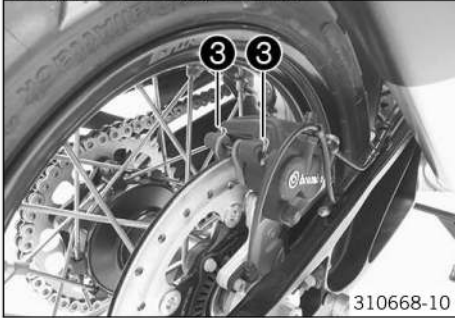

310668-10



K00005-10

- Operate the foot brake lever repeatedly until the brake linings are in contact with the brake disc and there is a pressure point.
- Correct the brake fluid level to the **MAX** marking ①.

Brake fluid DOT 4 / DOT 5.1 (📖 p. 338)

- Mount and tighten screw cap ① with membrane ②.



**Info**

Using water, immediately clean up any brake fluid that overflows or spills.

## 16.9 Adjusting the basic position of the foot brake lever

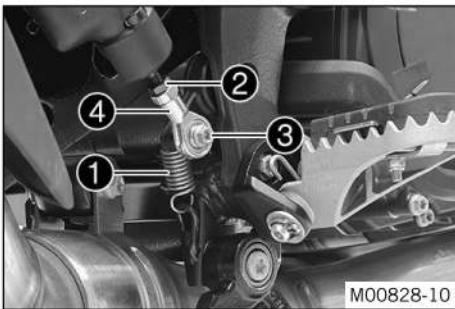

M00828-10

- Disconnect spring ①.
- Loosen nut ②.
- Remove screw ③.
- To adjust the basic position of the foot brake lever to individual requirements, turn ball joint ④ accordingly.



**Info**

The range of adjustment is limited.

The screw must be screwed into the ball joint by at least 5 turns.

- Hold ball joint ④ and tighten nut ②.

Guideline

Remaining chassis nuts	M6	10 Nm (7.4 lbf ft)
------------------------	----	--------------------

- Mount and tighten screw ③.

Guideline

Screw, ball joint of push rod on foot brake cylinder	M6	10 Nm (7.4 lbf ft)	Loctite® 243™
--	----	--------------------	---------------

- Attach spring ①.

## 16.10 Checking the rear brake fluid level

**Warning**

**Danger of accidents** An insufficient brake fluid level will cause the brake system to fail.

If the brake fluid level drops below the **MIN** marking, the brake system is leaking or the brake linings are worn down.

- Check the brake system and do not continue riding until the problem is eliminated.

**Warning**

**Danger of accidents** Old brake fluid reduces the braking effect.

- Make sure that brake fluid for the front and rear brake is changed in accordance with the service schedule.

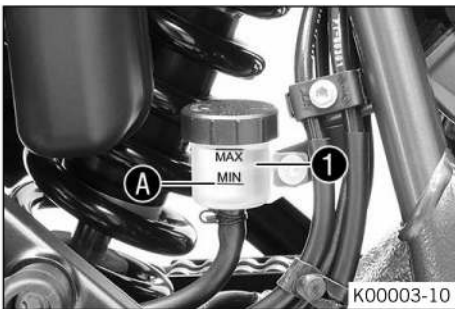
**Preparatory work**

- Raise the vehicle with the center stand. (📖 p. 12)

**Main work**

- Check the brake fluid level in the brake fluid reservoir ①.
  - » If the fluid level reaches the **MIN** marking A:
    - Add rear brake fluid. (📖 p. 142)

## 16.11 Adding rear brake fluid

**Warning**

**Danger of accidents** An insufficient brake fluid level will cause the brake system to fail.

If the brake fluid level drops below the **MIN** marking, the brake system is leaking or the brake linings are worn down.

- Check the brake system and do not continue riding until the problem is eliminated.

**Warning**

**Skin irritation** Brake fluid causes skin irritation.

- Keep brake fluid out of the reach of children.
- Wear suitable protective clothing and safety glasses.
- Do not allow brake fluid to come into contact with the skin, the eyes or clothing.
- Consult a doctor immediately if brake fluid has been swallowed.
- Rinse the affected area with plenty of water in the event of contact with the skin.
- Rinse eyes thoroughly with water immediately and consult a doctor if brake fluid comes into contact with the eyes.
- If brake fluid spills on to your clothing, change the clothing.

**Warning**

**Danger of accidents** Old brake fluid reduces the braking effect.

- Make sure that brake fluid for the front and rear brake is changed in accordance with the service schedule.

**Warning**

**Environmental hazard** Hazardous substances cause environmental damage.

- Dispose of oils, grease, filters, fuel, cleaning agents, brake fluid, etc., correctly and in compliance with the applicable regulations.

**Info**

Never use DOT 5 brake fluid. It is silicone-based and purple in color. Oil seals and brake lines are not designed for DOT 5 brake fluid.

Avoid contact between brake fluid and painted parts. Brake fluid attacks paint.

Only use clean brake fluid from a sealed container.

**Preparatory work**

- Raise the vehicle with the center stand. (📖 p. 12)
- Check the rear brake linings. (📖 p. 139)



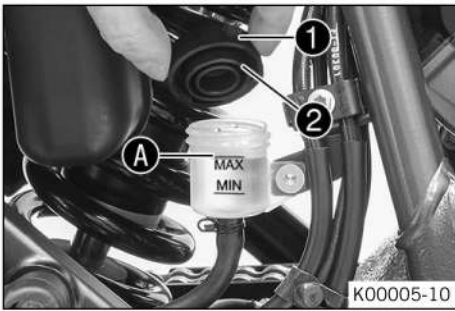

**Main work**

- Remove screw cap ① with membrane ②.
- Add brake fluid up to **MAX** marking A.

Brake fluid DOT 4 / DOT 5.1 (📖 p. 338)

- Mount and tighten screw cap ① with membrane ②.

**i Info**

Clean up overflowed or spilled brake fluid immediately with water.

## 16.12 Changing the rear brake fluid

**⚠ Warning**

**Skin irritation** Brake fluid causes skin irritation.

- Keep brake fluid out of the reach of children.
- Wear suitable protective clothing and safety glasses.
- Do not allow brake fluid to come into contact with the skin, the eyes or clothing.
- Consult a doctor immediately if brake fluid has been swallowed.
- Rinse the affected area with plenty of water in the event of contact with the skin.
- Rinse eyes thoroughly with water immediately and consult a doctor if brake fluid comes into contact with the eyes.
- If brake fluid spills on to your clothing, change the clothing.

**☀ Warning**

**Environmental hazard** Hazardous substances cause environmental damage.

- Dispose of oils, grease, filters, fuel, cleaning agents, brake fluid, etc., correctly and in compliance with the applicable regulations.

**i Info**

Avoid contact between brake fluid and painted parts. Brake fluid attacks paint!  
Use only clean brake fluid from a sealed container.



- Cover the painted parts.
- Remove screw cap ① with the membrane.
- Extract the old brake fluid from the brake fluid reservoir with a syringe and add fresh brake fluid.

Bleed syringe (50329050000) (📖 p. 344)

Brake fluid DOT 4 / DOT 5.1 (📖 p. 338)

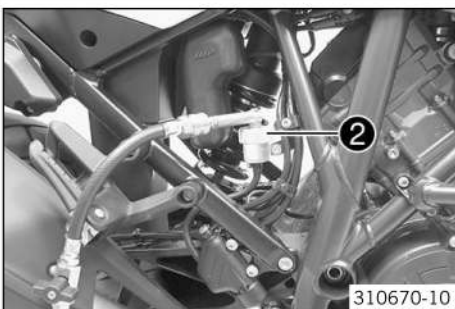

- Mount bleeder cover ②.

Bleeder cover (00029013004) (📖 p. 342)

- Connect the bleeder device.

Bleeding device (00029013100) (📖 p. 342)

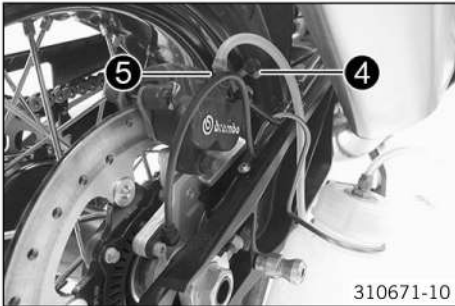
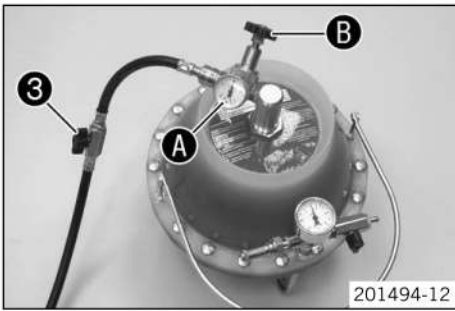

- Open shut-off valve ③.

**i Info**  
Follow the operating instructions of the bleeding device.

- Ensure that the filling pressure is set on pressure gauge ①. Adjust the filling pressure on pressure regulator ② if necessary.

Guideline

Filling pressure	2... 2.5 bar (29... 36 psi)
------------------	-----------------------------

- Pull off protection cap ④ of the bleeder screw. Connect the hose of the bleeder bottle.

Bleeding device (00029013100) (📖 p. 342)
--

- Open bleeder screw ⑤ by approx. one-half turn.

**i Info**  
Drain until the fresh brake fluid emerges from the hose of the bleeder bottle without bubbles.

- Tighten the bleeder screw.
- Close shut-off valve ③.
- Open the bleeder screw again until brake fluid stops emerging.  
✓ This prevents overfilling of the brake fluid reservoir.
- Tighten the bleeder screw. Remove the hose of the bleeder bottle. Mount the protection cap.
- Lock the bleeding device. Remove the bleeder cover.
- Correct the brake fluid to the **MAX** marking.

Brake fluid DOT 4 / DOT 5.1 (📖 p. 338)
--

- Mount and tighten the screw cap with the membrane.

**i Info**  
Clean up overflowed or split brake fluid immediately with water.

## 17.1 Removing the headlight mask with the headlight

### Preparatory work

- Switch off all power consumers and switch off the engine.
- Remove the wind shield. (📖 p. 94)
- Remove the passenger seat. (📖 p. 72)
- Remove the front rider's seat. (📖 p. 71)
- Remove the crash bar. (📖 p. 32)
- Remove the front side cover. (📖 p. 87)
- Remove the tank cover. (📖 p. 89)
- Remove the mask spoiler. (📖 p. 90)

### Main work

- Remove screws ❶.
- Take off the windshield adapter ❷.

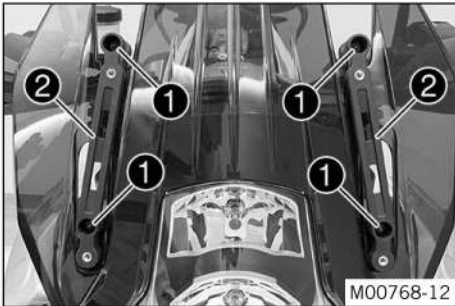

- Remove screws ❸.
- Fold the headlight mask forward.

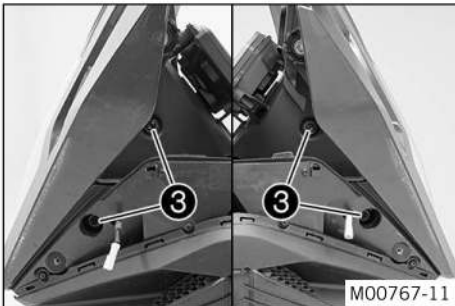

- Disconnect plug-in connector ❹.
- Put the the headlight mask on a soft cloth so that the headlight does not get damaged.

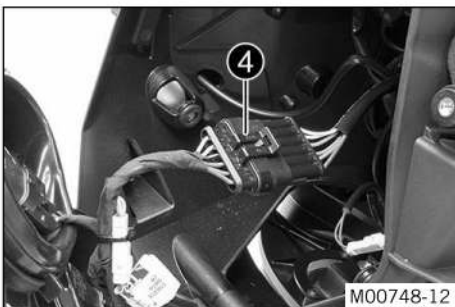

## 17.2 Installing the headlight mask with the headlight

### Main work

- Connect plug-in connector ❶ of the headlight.
- Check that the lighting is functioning properly.
- Position the headlight mask.

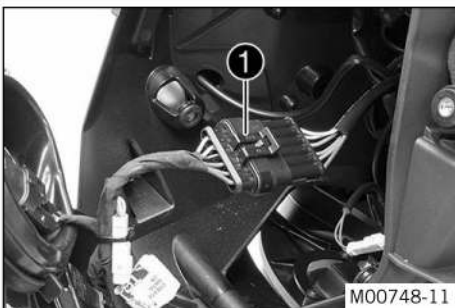

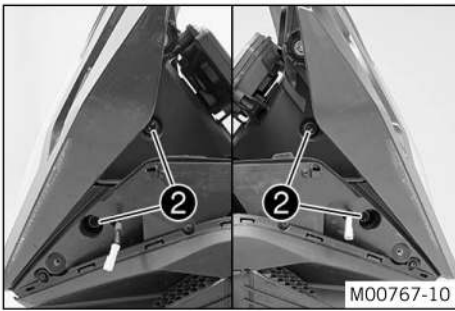

- Mount and tighten screws ②.

Guideline

Screw, headlight	M6	5 Nm (3.7 lbf ft)
------------------	----	-------------------

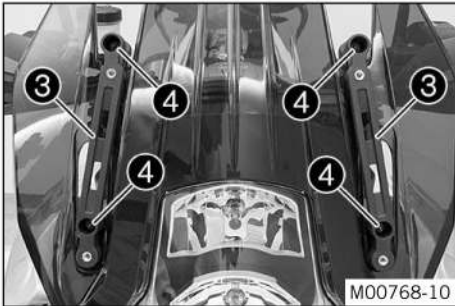

- Position windshield adapter ③.
- Mount and tighten screws ④.

Guideline

Screw, cover part	M5	3.5 Nm (2.58 lbf ft)
-------------------	----	-------------------------

**Finishing work**

- Install the mask spoiler. (📖 p. 92)
- Install the tank cover. (📖 p. 89)
- Install the front side cover. (📖 p. 87)
- Install the crash bar. (📖 p. 32)
- Mount the front rider's seat. (📖 p. 71)
- Mount the passenger seat. (📖 p. 72)
- Install the wind shield. (📖 p. 95)
- Check the setting of the lighting system. (📖 p. 148)

## 17.3 Changing the low beam bulb

**Note**

**Damage to reflector** Grease on the reflector reduces the brightness.

Grease on the bulb will evaporate due to the heat and be deposited on the reflector.

- Clean and degrease the bulbs before mounting.
- Do not touch the bulbs with your bare hands.

**Preparatory work**

- Switch off all power consumers and switch off the engine.
- Remove the wind shield. (📖 p. 94)
- Remove the passenger seat. (📖 p. 72)
- Remove the front rider's seat. (📖 p. 71)
- Remove the crash bar. (📖 p. 32)
- Remove the front side cover. (📖 p. 87)
- Remove the tank cover. (📖 p. 89)
- Remove the mask spoiler. (📖 p. 90)
- Remove the headlight mask with the headlight. (📖 p. 145)

**Main work**

- Push headlight bulb ① lightly into the bulb socket, turn it all the way counter-clockwise, and pull it out.
- Unplug connector ②.

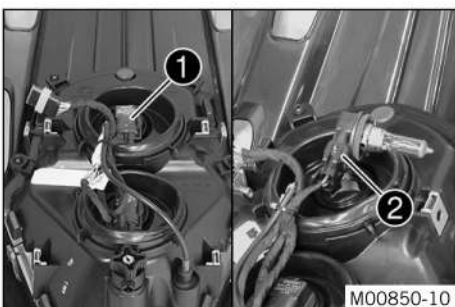

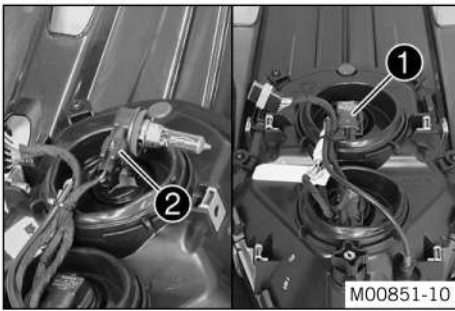

- Plug connector ② into the new headlight bulb.

Low beam (H11/socket PGJ19-2) (p. 301)

- Position headlight bulb ① into the bulb socket and turn it all the way clockwise.
  - ✓ The headlight bulb is locked into the bulb socket.

### Finishing work

- Install the headlight mask with the headlight. (p. 145)
- Install the mask spoiler. (p. 92)
- Install the tank cover. (p. 89)
- Install the front side cover. (p. 87)
- Install the crash bar. (p. 32)
- Mount the front rider's seat. (p. 71)
- Mount the passenger seat. (p. 72)
- Install the wind shield. (p. 95)
- Check the setting of the lighting system. (p. 148)

## 17.4 Changing the high beam bulb

### Note

**Damage to reflector** Grease on the reflector reduces the brightness.  
Grease on the bulb will evaporate due to the heat and be deposited on the reflector.

- Clean and degrease the bulbs before mounting.
- Do not touch the bulbs with your bare hands.

### Preparatory work

- Switch off all power consumers and switch off the engine.
- Remove the wind shield. (p. 94)
- Remove the passenger seat. (p. 72)
- Remove the front rider's seat. (p. 71)
- Remove the crash bar. (p. 32)
- Remove the front side cover. (p. 87)
- Remove the tank cover. (p. 89)
- Remove the mask spoiler. (p. 90)
- Remove the headlight mask with the headlight. (p. 145)

### Main work

- Push headlight bulb ① lightly into the bulb socket, turn it all the way counter-clockwise, and pull it out.
- Unplug connector ②.

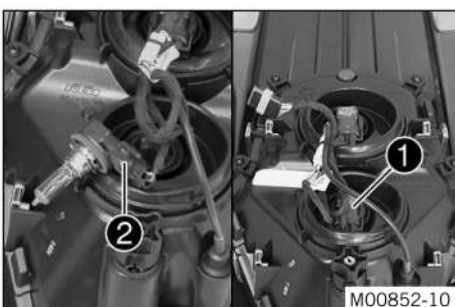
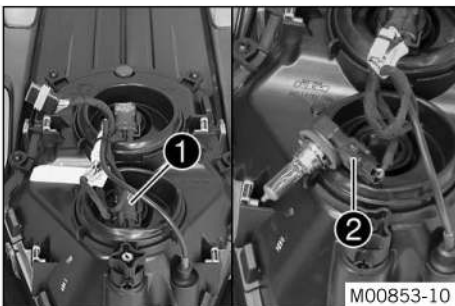

- Plug connector ② into the new headlight bulb.

High beam (H11/socket PGJ19-2) (p. 301)

- Position headlight bulb ① into the bulb socket and turn it all the way clockwise.
  - ✓ The headlight bulb is locked into the bulb socket.

### Finishing work

- Install the headlight mask with the headlight. (📖 p. 145)
- Install the mask spoiler. (📖 p. 92)
- Install the tank cover. (📖 p. 89)
- Install the front side cover. (📖 p. 87)
- Install the crash bar. (📖 p. 32)
- Mount the front rider's seat. (📖 p. 71)
- Mount the passenger seat. (📖 p. 72)
- Install the wind shield. (📖 p. 95)
- Check the setting of the lighting system. (📖 p. 148)

## 17.5 Checking the setting of the lighting system

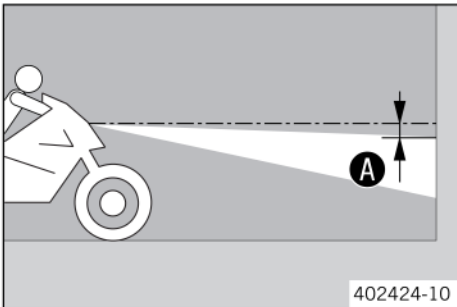

- Position the vehicle upright on a horizontal surface in front of a light wall and make a mark at the height of the center of the low beam headlight.
- Make a second mark at a distance **A** under the first mark.

#### Guideline

Distance <b>A</b>	5 cm (2 in)
-------------------	-------------

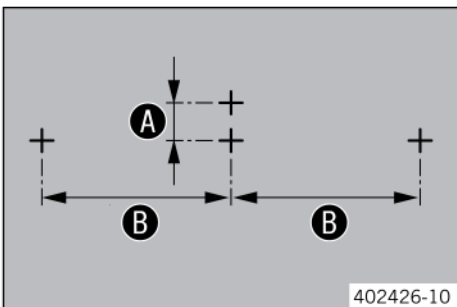

- Make two further marks spaced apart **B** to the left and the right of the second marking.

#### Guideline

Distance <b>B</b>	71.5 cm (28.15 in)
-------------------	--------------------

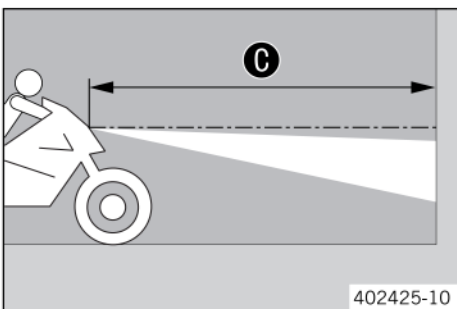

- Position the vehicle perpendicular to the wall at a distance **C** from the wall and switch on the low beam.

#### Guideline

Distance <b>C</b>	5 m (16 ft)
-------------------	-------------

- The rider, with luggage and passenger if applicable, now mounts the motorcycle.
- Check the headlight setting.

The light-dark boundary of the low beam must lie exactly on the lower mark when the motorcycle is ready to operate with the rider mounted along with any luggage and a passenger if applicable.

- » If the boundary between light and dark does not meet specifications:

- Adjust the headlight range. (📖 p. 149)

- Press the **UP** or **DOWN** button until the "**Settings**" menu appears on the matrix display. Pressing the **SET** button opens the menu.
- Press the **UP** or **DOWN** button until "**cLightTest**" is highlighted in black on the matrix display. Pressing the **SET** button again starts the cornering light test.
- Wait for a few seconds until the upper segment of the left cornering light lights up continuously.
- Checking the left cornering light setting.

The light-dark boundary of the upper segment must run exactly through the left marking.

- » If the boundary between light and dark does not meet specifications:

- Adjust the cornering light range. (📖 p. 149)

- Press the **SET** button.
  - ✓ The left cornering light is switched off.
  - ✓ The right cornering light test is started.

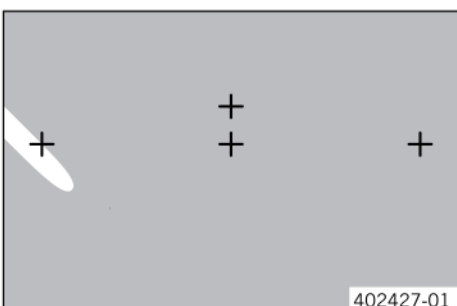

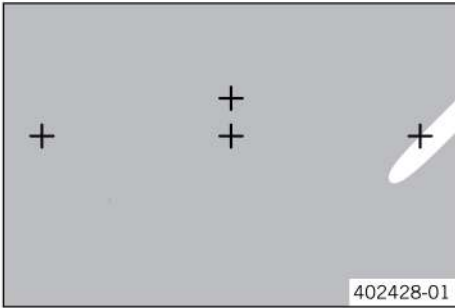

- Wait for a few seconds until the upper segment of the right cornering light lights up continuously.
- Checking the right cornering light setting.
 

The light-dark boundary of the upper segment must run exactly through the right marking.

  - » If the boundary between light and dark does not meet specifications:
    - Adjust the cornering light range. (p. 149)
- Press the **SET** button.
  - ✓ The cornering light is switched off.

## 17.6 Adjusting the headlight range

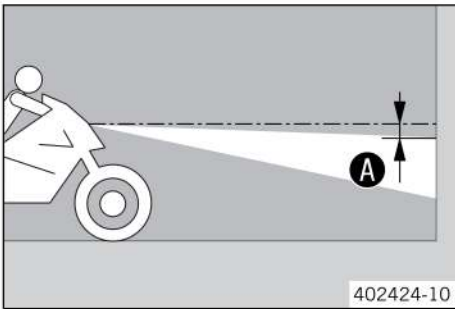
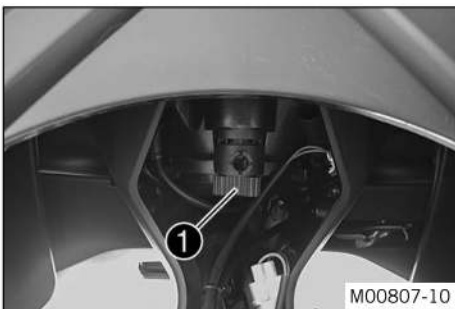

### Preparatory work

- Check the setting of the lighting system. (p. 148)
- Remove the bottom triple clamp cover. (p. 93)

### Main work

- Turn adjusting screw **1** to adjust the headlight range.

**i Info**  
 Turn clockwise to increase the headlight range; turn counterclockwise to reduce the headlight range.  
 If you have a payload, you may have to correct the headlight range.

- Set the headlight to marking **A**.

### Guideline

The light-dark boundary must lie exactly on the lower mark **A** when the motorcycle is ready to operate with the rider mounted along with any luggage and a passenger if applicable.

### Finishing work

- Install the bottom triple clamp cover. (p. 93)

## 17.7 Adjusting the cornering light range



### Preparatory work

- Check the setting of the lighting system. (p. 148)

### Main work

- Press the **UP** or **DOWN** button until the "Settings" menu appears on the matrix display. Pressing the **SET** button opens the menu.
- Press the **UP** or **DOWN** button until "cLightTest" is highlighted in black on the matrix display. Pressing the **SET** button again starts the cornering light test.
- Wait for a few seconds until the upper segment of the left cornering light lights up continuously.
- Turn adjusting screw **1** to adjust the left cornering light range.

**i Info**  
 Turn clockwise to increase the headlight range; turn counterclockwise to reduce the headlight range.

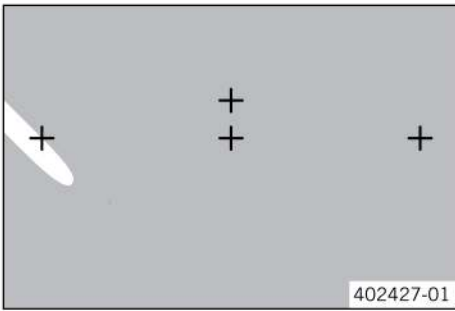

- Set the upper segment on the left marking.

Guideline

The light-dark boundary of the upper segment must run exactly through the left marking.

- Press the **SET** button.
  - ✓ The left cornering light is switched off.
  - ✓ The right cornering light test is started.
- Wait for a few seconds until the upper segment of the right cornering light lights up continuously.
- Turn adjusting screw ② to adjust the right cornering light range.

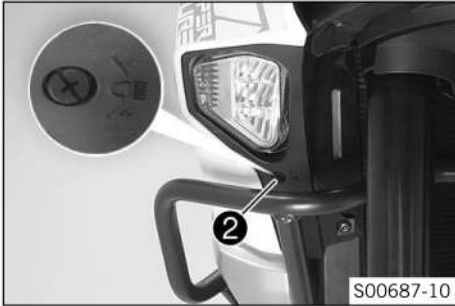

**i** Info

Turn clockwise to increase the headlight range; turn counterclockwise to reduce the headlight range.



- Set the upper segment on the left marking.

Guideline

The light-dark boundary of the upper segment must run exactly through the right marking.

- Press the **SET** button.
  - ✓ The cornering light is switched off.

## 17.8 Activating/deactivating the ignition key

**i** Info

The orange programming key must only be used for activating and deactivating!

If a black ignition key is lost or needs to be replaced, the individual black ignition keys need to be enabled or disabled using the orange programming key. This prevents the vehicle from being operated with the lost black ignition key.

You can activate or deactivate up to four black ignition keys. Only the black ignition keys programmed during an activation procedure are valid. All black ignition keys not programmed during the activation procedure are invalid, but can be reprogrammed in a further activation procedure.

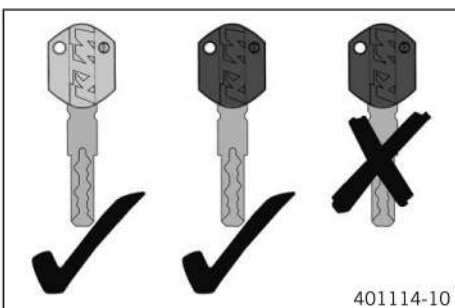

**Loss of a black ignition key (additional black ignition keys are available):**

The following procedure deactivates all activated black ignition keys that are not included in the procedure.

- Press the emergency OFF switch to the position **ON** ○.



- Insert the orange programming key in the ignition lock.
- Switch on the ignition by turning the orange programming key to the **ON** position ○.
  - ✓ Immobilizer ■ indicator lamp lights up.
- Switch off the ignition by turning the orange programming key to the **OFF** position ☒.
- Pull out the orange programming key.
- Insert the black ignition key in the ignition lock.
- Switch on the ignition by turning the black ignition key to the position **ON** ○.
  - ✓ Immobilizer ■ indicator lamp lights up.



- Switch off the ignition by turning the black ignition key to the position **OFF** ☒.
- Remove the black ignition key.
- Insert the orange programming key in the ignition lock.
- Switch on the ignition by turning the orange programming key to the **ON** position ○.
- ✓ The immobilizer ■ indicator lamp flashes according to the number of functional black ignition keys including the orange programming key. In this case, it flashes twice.
- Switch off the ignition by turning the orange programming key to the **OFF** position ☒.
- Pull out the orange programming key.
- ✓ The lost black ignition key is deactivated.
- ✓ The existing black ignition key is reactivated.

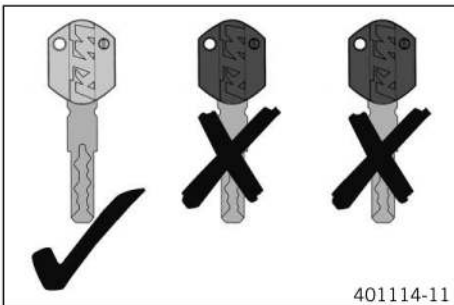



**Loss of all black ignition keys (no black ignition keys are available):**

This procedure is important to prevent misuse of the lost black ignition key.

- Press the emergency OFF switch to the position **ON** ○.
- Insert the orange programming key in the ignition lock.
- Switch on the ignition by turning the orange programming key to the **ON** position ○.
- ✓ Immobilizer ■ indicator lamp lights up.
- Switch off the ignition by turning the orange programming key to the **OFF** position ☒.
- Switch on the ignition by turning the orange programming key to the **ON** position ○.
- ✓ The immobilizer ■ indicator lamp flashes according to the number of functional black ignition keys including the orange programming key. In this case, it flashes once since all black ignition keys are deactivated.
- Switch off the ignition by turning the orange programming key to the **OFF** position ☒.
- Pull out the orange programming key.
- ✓ All black ignition keys are deactivated.
- Order a new black ignition key according to the key number on the **KEYCODECARD** and activate it.







**To activate up to three black ignition keys:**

- Press the emergency OFF switch to the position **ON** ○.
- Insert the orange programming key in the ignition lock.
- Switch on the ignition by turning the orange programming key to the **ON** position ○.
- ✓ Immobilizer ■ indicator lamp lights up.
- Switch off the ignition by turning the orange programming key to the **OFF** position ☒.
- Pull out the orange programming key.
- Insert the black ignition key in the ignition lock.
- Switch on the ignition by turning the black ignition key to the position **ON** ○.
- ✓ Immobilizer ■ indicator lamp lights up.
- Switch off the ignition by turning the black ignition key to the position **OFF** ☒.
- Remove the black ignition key.
- If two other black ignition keys are to be activated, repeat the last steps with the respective ignition key.
- If the last black ignition key was activated, insert the orange programming key into the ignition lock.

- Switch on the ignition by turning the orange programming key to the **ON** position .
- ✓ The immobilizer  indicator lamp flashes according to the number of functional black ignition keys including the orange programming key.
- Switch off the ignition by turning the orange programming key to the **OFF** position .
- Pull out the orange programming key.

**i Info**  
Activation of the ignition key is finished.

**To activate four black ignition keys:**







- Press the emergency OFF switch to the position **ON** .
- Insert the orange programming key in the ignition lock.
- Switch on the ignition by turning the orange programming key to the **ON** position .
- ✓ Immobilizer  indicator lamp lights up.
- Switch off the ignition by turning the orange programming key to the **OFF** position .
- Pull out the orange programming key.
- Insert the black ignition key in the ignition lock.
- Switch on the ignition by turning the black ignition key to the position **ON** .
- ✓ Immobilizer  indicator lamp lights up.
- Switch off the ignition by turning the black ignition key to the position **OFF** .
- Remove the black ignition key.
- If three other black ignition keys are to be activated, repeat the last steps with the respective ignition key.

**i Info**  
After the fourth black ignition key has been activated, programming is finished.

## 17.9 Programming the switch for the cruise control system



311100-10

- Switch on the ignition.
- ✓ The cruise control system lamp  flashes.
- Press the switch for the cruise control system .
- Press the switch for the cruise control system  again.
- Press the top button of the cruise control system  again.
- Press the bottom button of the cruise control system  again.
- Turn the throttle grip forward past the neutral position.
- ✓ The cruise control system lamp  goes out.
- Switch off ignition.

## 17.10 Resetting the service display using the KTM diagnostic tool

### Condition

The diagnostic tool is connected and running.

- Select "**Combination instrument**" > "**Functions**" > "**Service interval**".
- Enter the distance until the next service is due.
- Select the unit for the distance.
- Quit the process using "**Execute**".



## 18.1 Removing the engine

**Preparatory work**

- Raise the vehicle with the center stand. (📖 p. 12)
- Remove the engine guard. (📖 p. 43)
- Remove the passenger seat. (📖 p. 72)
- Remove the front rider's seat. (📖 p. 71)
- Disconnect the negative (minus) cable of the battery. (📖 p. 126)
- Remove the crash bar. (📖 p. 32)
- Remove the front side cover. (📖 p. 87)
- Remove the tank cover. (📖 p. 89)
- Remove the mask spoiler. (📖 p. 90)
- Remove the fuel tank. (📖 p. 73)
- Remove the upper part of the air filter box. (📖 p. 66)
- Remove the lower part of the air filter box. (📖 p. 68)
- Remove the throttle valve body. (📖 p. 292)
- Drain the coolant. (📖 p. 256)
- Disassemble the main silencer. (📖 p. 60)
- Remove the manifold. (📖 p. 61)

**Main work**

- Remove screw ❶.
- Remove heat protector ❷.

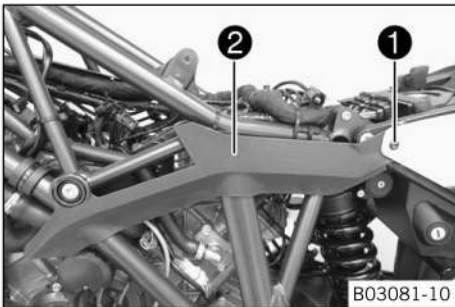

- Remove screw ❸.
- Remove heat protector ❹.

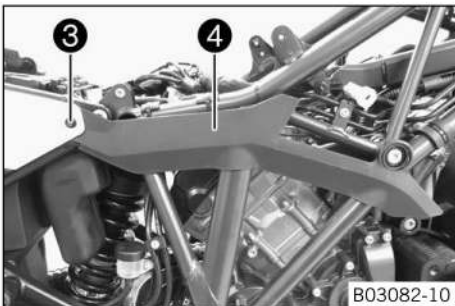

- Remove screw ❺.
- Remove heat protector ❻.

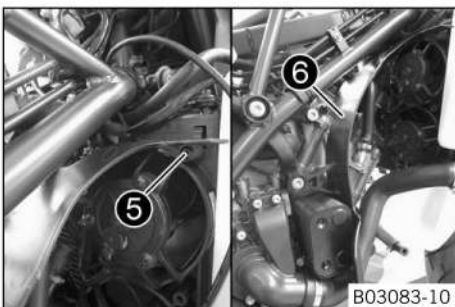

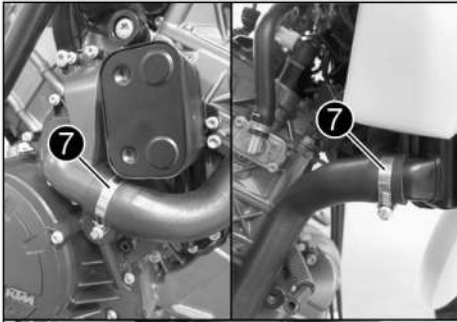

- Loosen hose clips **7**.
- Remove the radiator hose on the right.
- Pull off the radiator hose from the radiator on the left.



D00973-10

- Pull both connectors **8** off the holder and disconnect them.

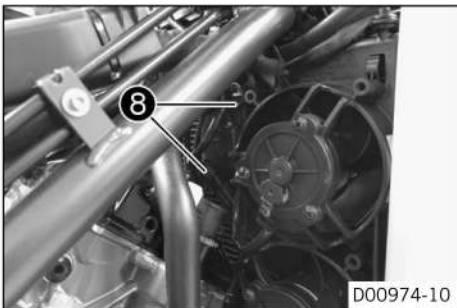

D00974-10

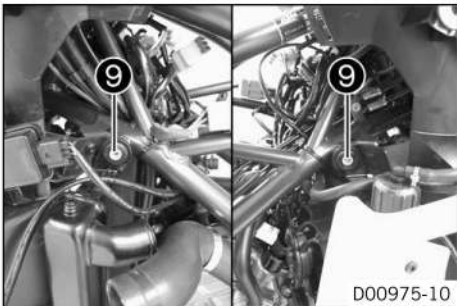

D00975-10

- Remove screws **9**.
- Remove the radiator in a downward direction.



D00976-10

- Remove screw **10**.

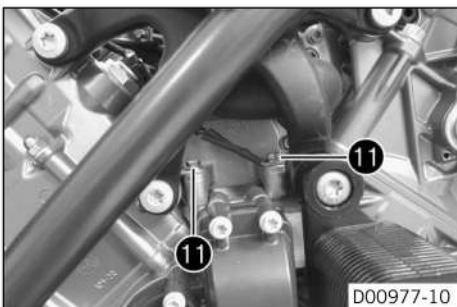

D00977-10

- Remove screws **11**.
- Hang the ground wire to the side.

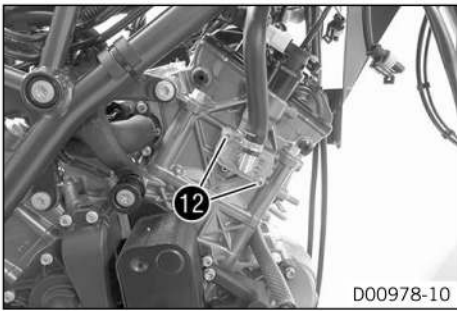

- Remove screws 12.

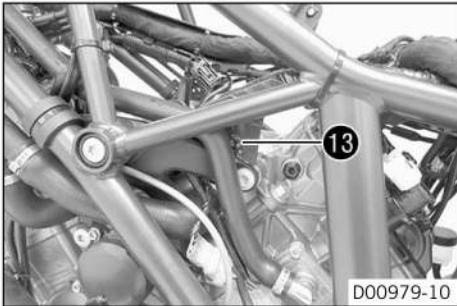

- Remove screw 13.

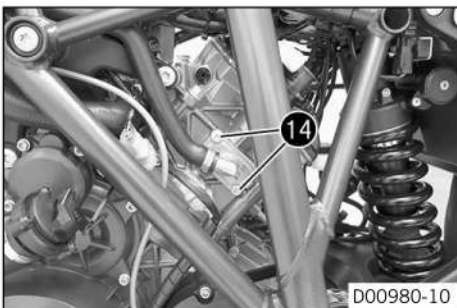

- Remove screws 14.
- Remove the cable tie(s).

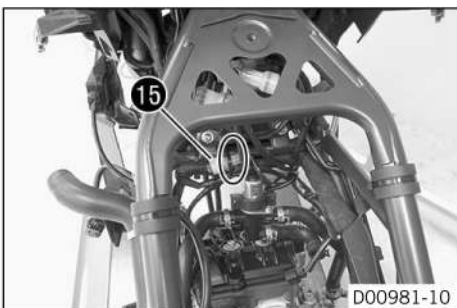

- Remove the cable tie(s).
- Unplug connector 15.
- Remove the SAS valve with hoses.

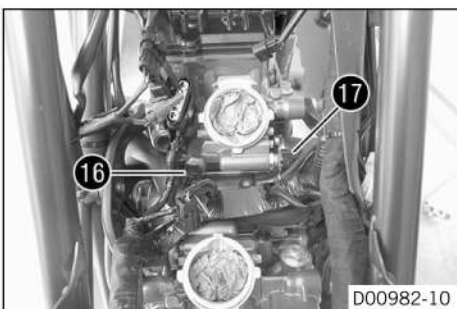

- Unplug connector 16.
- Unplug connector 17.

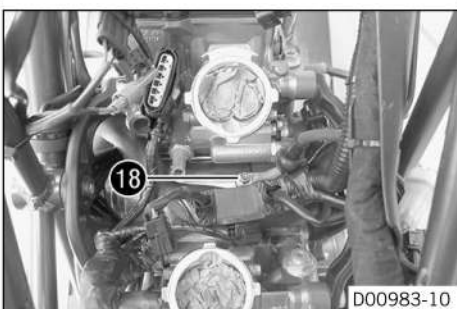

- Push back the rubber cap.
- Remove nut 18 and hang the positive cable to the side.

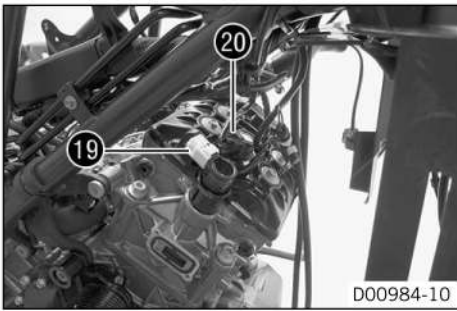

- Unplug connector 19.
- Unplug connector 20.

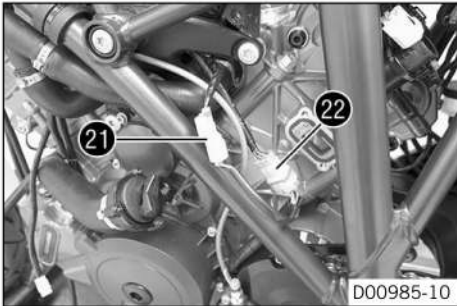

- Remove the cable guard.
- Unplug connector 21.
- Unplug connector 22.
- Expose the cable.

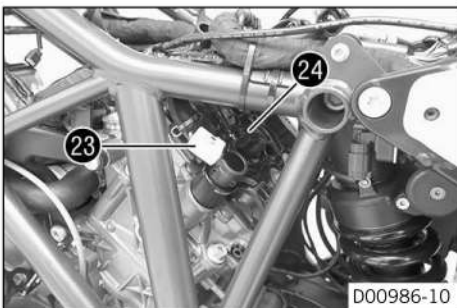

- Unplug connector 23.
- Unplug connector 24.

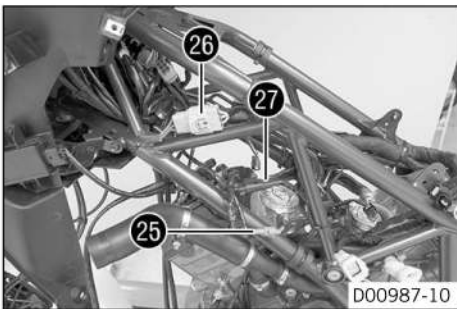

- Unplug connector 25.
- Unplug connector 26.
- Unplug connector 27.
- Expose the cable.

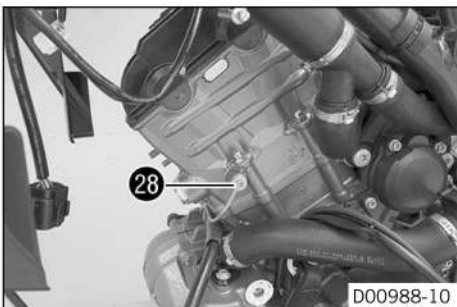

- Remove screw 28.
- Remove the fuel hose with the holder.

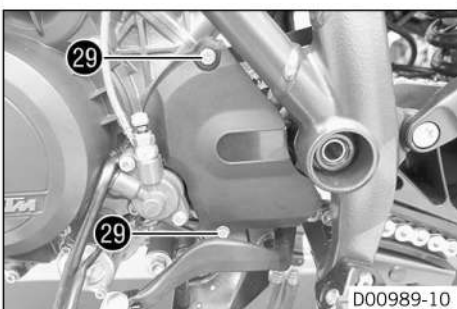

- Remove screws 29.
- Take off the engine sprocket cover.

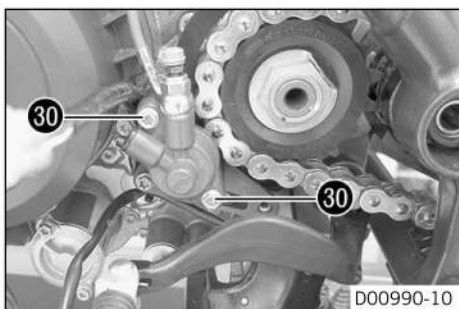

- Remove screws 30.
- Take off the slave cylinder of the clutch and hang it to one side.

**i Info**

Do not activate the clutch lever while the slave cylinder of the clutch is removed.  
Do not kink the clutch line.

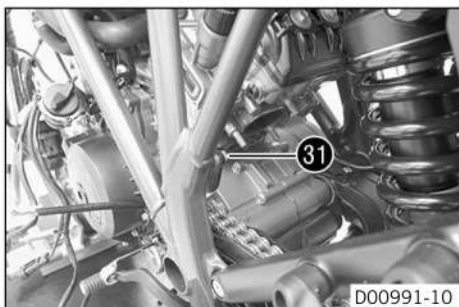

- Remove screw 31.

**i Info**

Do not misplace the spacer.

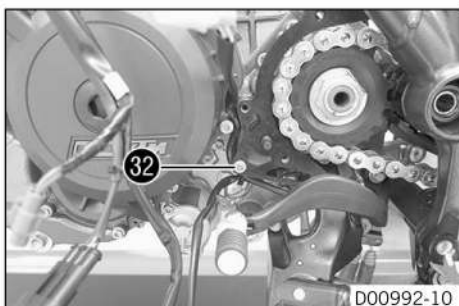

- Remove screw 32.
- Remove the chain securing guide with the spacer.

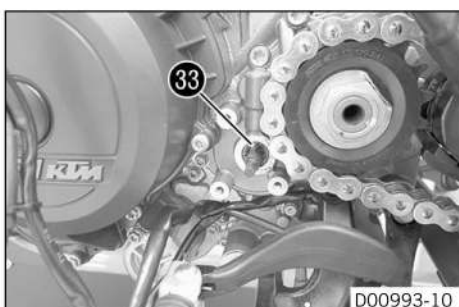

- Remove pin 33.

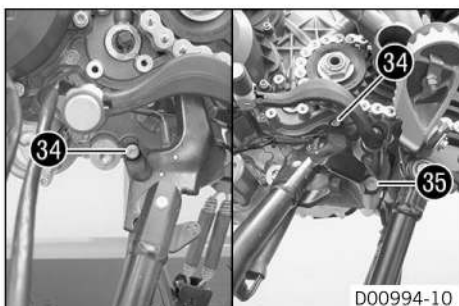

- Remove screws 34.
- Remove screw 35.
- Remove the side stand bracket.

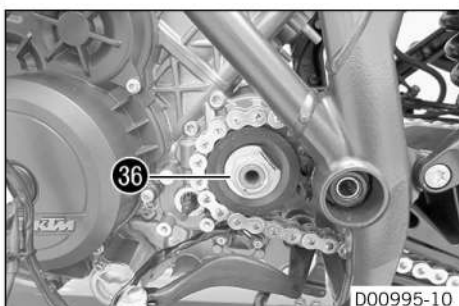

- Have an assistant operate the rear brake.
- Bend up the lock washer.
- Loosen nut 36.





- Secure the motorcycle against falling over with belts.



- Remove nut 37.
- Remove the chain adjuster.



- Push the rear wheel into the foremost position.
- Remove the chain from the rear sprocket.



**Info**

Protect the swingarm and components from damage.

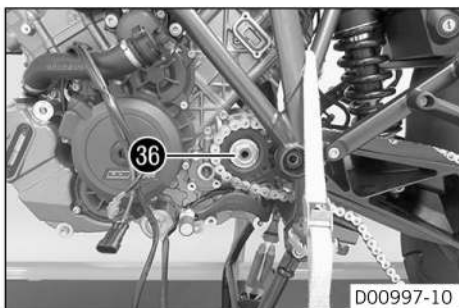

- Remove nut 36 with the lock washer.
- Take off the engine sprocket.

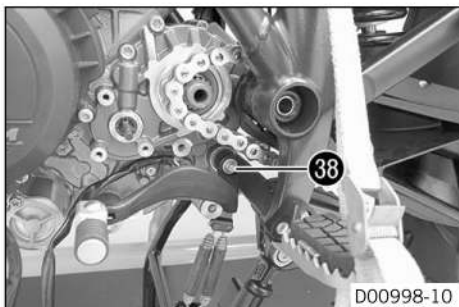

- Remove screw 38 with the washer.
- Take off the shift lever.

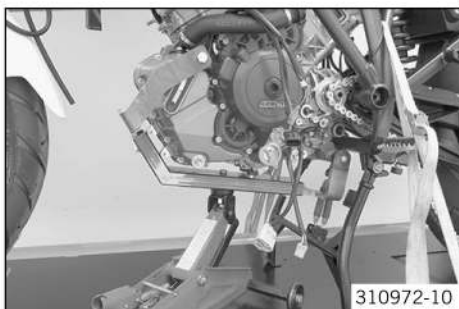

- Position the floor jack with the special tool.

Floor jack attachment (61329055000) (📖 p. 352)



**Info**

It is a good idea to have assistance when carrying out the following procedures.

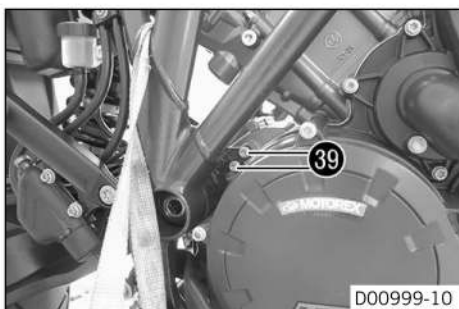

- Remove screws 39.
- Remove the swing angle sensor and hang it to the side.

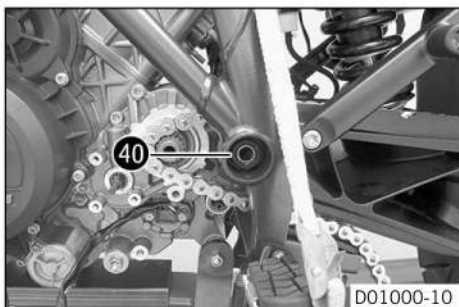

- Remove nut 40.
- Pull out the swingarm pivot.

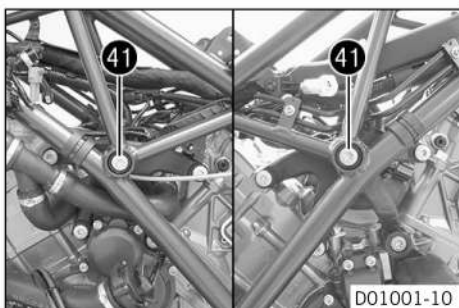

- Remove screws 41 with bearing.

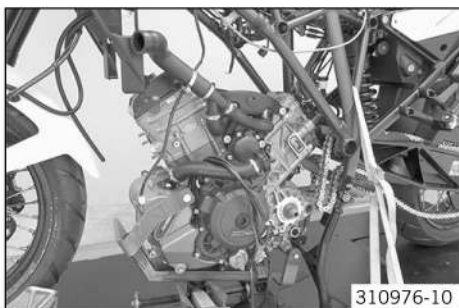

- Pull the engine forward slightly and lower carefully.

**i Info**  
The help of an assistant is useful in this step.

## 18.2 Installing the engine

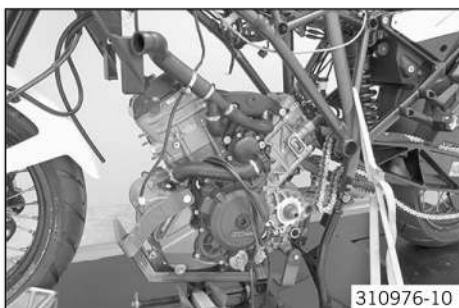

### Preparatory work

- Prepare the engine for installation. (📖 p. 168)

### Main work

- Position the engine on a floor jack under the vehicle.

Floor jack attachment (61329055000) (📖 p. 352)

**i Info**  
The help of an assistant is useful in this step.

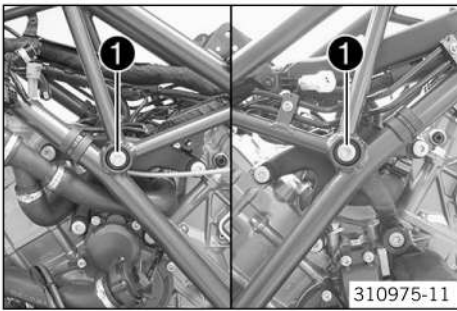

- Position the engine in the frame.
- Position screws **1** with bearing, but do not tighten yet.

Guideline

Engine carrying screw	M10	45 Nm (33.2 lbf ft)
-----------------------	-----	------------------------

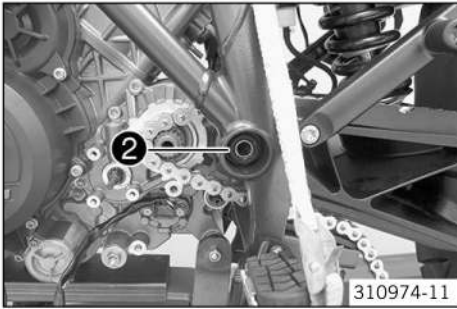

- Mount the swingarm pivot.
- Mount nut **2**, but do not tighten it yet.

Guideline

Nut, swingarm pivot	M19x1.5	130 Nm (95.9 lbf ft)	Thread greased
---------------------	---------	-------------------------	----------------

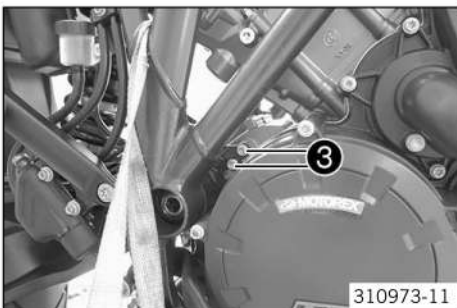

- Position the swing angle sensor.
- Mount and tighten screws **3**.

Guideline

Swing angle sensor screw	M5	5 Nm (3.7 lbf ft)	Loctite® 243™
--------------------------	----	----------------------	---------------

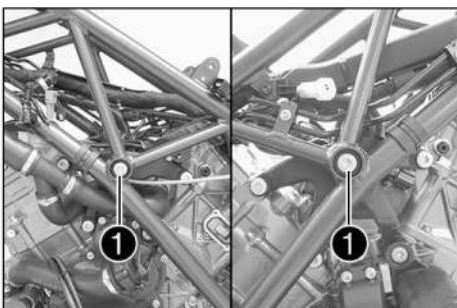

- Tighten screws **1**.

Guideline

Engine carrying screw	M10	45 Nm (33.2 lbf ft)
-----------------------	-----	------------------------

- Tighten nut **2**.

Guideline

Nut, swingarm pivot	M19x1.5	130 Nm (95.9 lbf ft)	Thread greased
---------------------	---------	-------------------------	----------------

- Remove the floor jack.

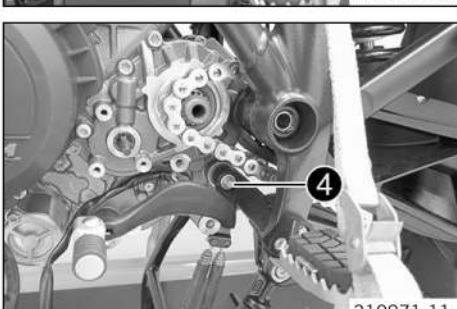
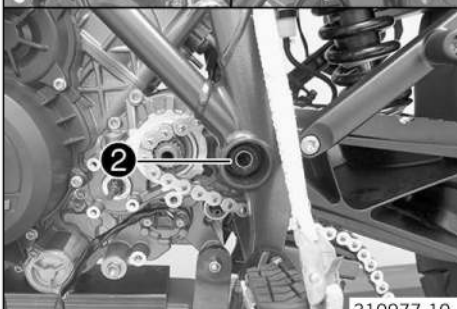

- Position the shift lever.
- Position and tighten screw **4** with washer.

Guideline

Screw, shift lever	M6	18 Nm (13.3 lbf ft)	Loctite® 243™
--------------------	----	------------------------	---------------

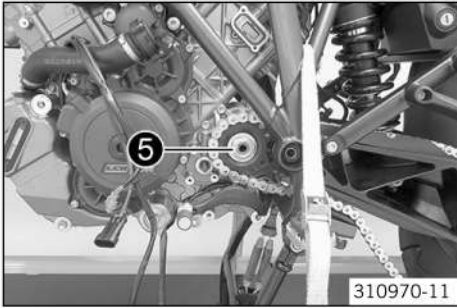

- Lay a chain over the engine sprocket.
- Mount the engine sprocket.
- Mount nut **5** with the lock washer, but do not tighten yet.

Guideline

Nut of engine sprocket	M20x1.5	100 Nm (73.8 lbf ft)	Loctite® 243™
------------------------	---------	-------------------------	---------------



- Lay a chain over the rear sprocket.



- Slide the wheel spindle in as far as it will go.
- Mount the chain adjuster.
- Push the rear wheel forward so that the chain adjusters are in contact with the screws, and tighten nut **6**.

Guideline

Nut, rear wheel spindle	M25x1.5	90 Nm (66.4 lbf ft)	Thread greased
-------------------------	---------	------------------------	----------------



- Remove the belts.

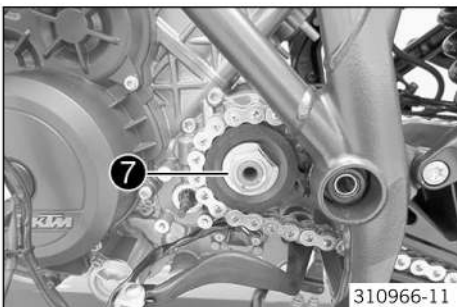

- Have an assistant operate the rear brake.
- Tighten nut **7**.

Guideline

Nut of engine sprocket	M20x1.5	100 Nm (73.8 lbf ft)	Loctite® 243™
------------------------	---------	-------------------------	---------------

- Secure the nut with the lock washer.

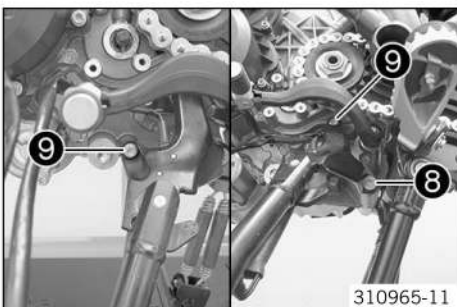

- Position the side stand bracket.
- Mount screw **8** but do not tighten yet.

Guideline

Screw, side stand bracket	M10	45 Nm (33.2 lbf ft)	Loctite® 243™
---------------------------	-----	------------------------	---------------

- Mount and tighten screws **9**.

Guideline

Screw, side stand bracket	M8	25 Nm (18.4 lbf ft)	
---------------------------	----	------------------------	--

- Tighten screw 8.

Guideline

Screw, side stand bracket	M10	45 Nm (33.2 lbf ft)	Loctite® 243™
---------------------------	-----	------------------------	---------------

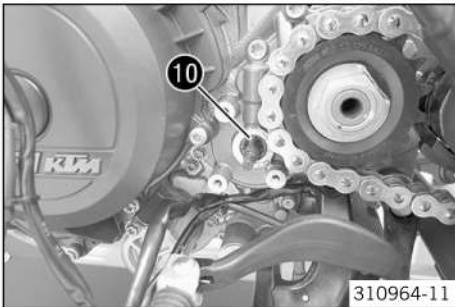

- Mount pin 10.

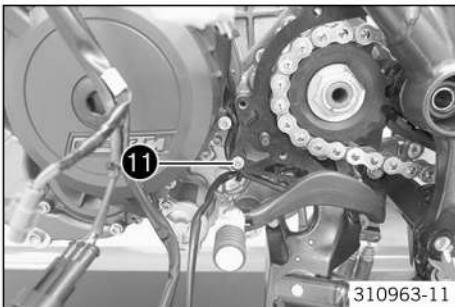

- Mount the chain securing guide with the spacer.
- Mount and tighten screw 11.

Guideline

Remaining chassis screws	M6	10 Nm (7.4 lbf ft)
--------------------------	----	--------------------

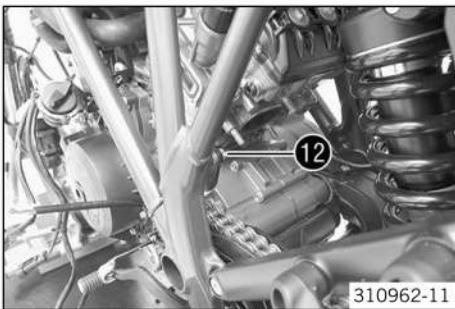

- Mount and tighten screw 12.

Guideline

Remaining chassis screws	M8	25 Nm (18.4 lbf ft)
--------------------------	----	------------------------

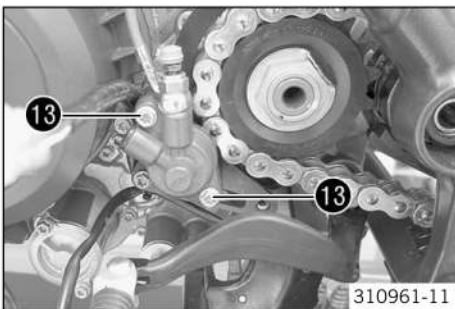

- Mount the clutch slave cylinder screw with spacer and sleeves.
- Route the clutch line without kinks.
- Mount and tighten screws 13.

Guideline

Clutch slave cylinder screw	M6	10 Nm (7.4 lbf ft)
-----------------------------	----	--------------------

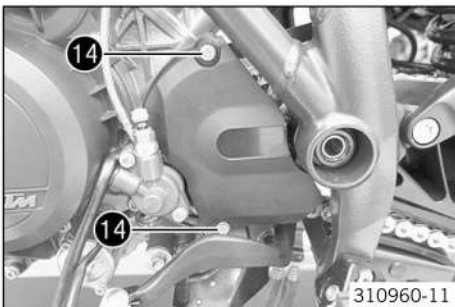

- Position the engine sprocket cover.
- Mount and tighten screws 14.

Guideline

Remaining chassis screws	M6	10 Nm (7.4 lbf ft)
--------------------------	----	--------------------

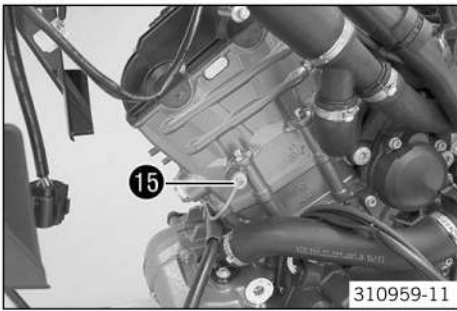

- Position the fuel line with the holder.
- Mount and tighten screw **15**.

Guideline

Remaining screws, engine	M6	10 Nm (7.4 lbf ft)
--------------------------	----	--------------------

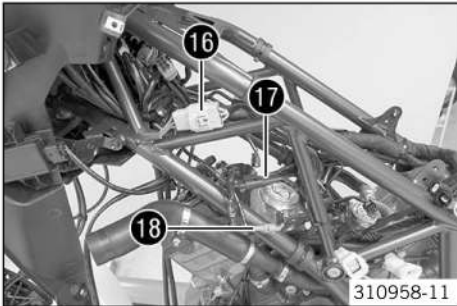

- Plug in connector **16**.
- Plug in connector **17**.
- Plug in connector **18**.
- Route the cable without tension and secure with cable tie(s).

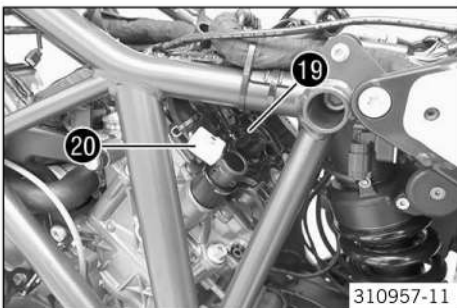

- Plug in connector **19**.
- Plug in connector **20**.
- ✓ The cable with the white marking is connected to the outer ignition coil.

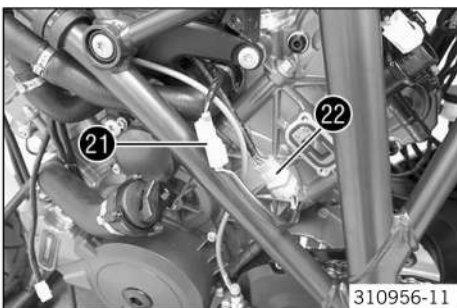

- Plug in connector **21**.
- Plug in connector **22**.
- Route the cable so it is not under tension and secure with a cable tie and a cable guard.

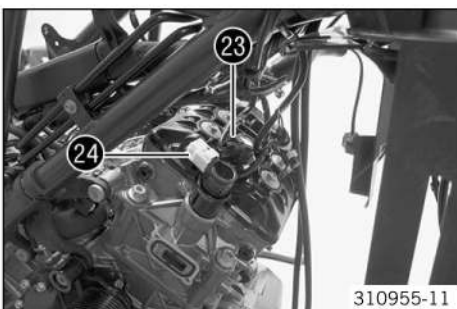

- Plug in connector **23**.
- Plug in connector **24**.
- ✓ The cable with the white marking is connected to the outer ignition coil.

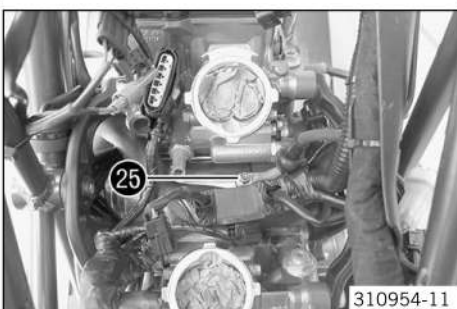

- Position the positive cable on the starter motor.
- Mount and tighten nut **25**.

Guideline

Nut, cable on starter motor	M6	4 Nm (3 lbf ft)
-----------------------------	----	-----------------

- Position the rubber cap.

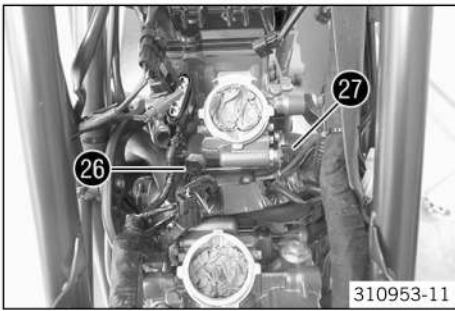

310953-11

- Plug in connector 26.
- Plug in connector 27.



310952-11

- Position the SAS valve with hoses.
- Plug in connector 28.
- Position the cable tie.

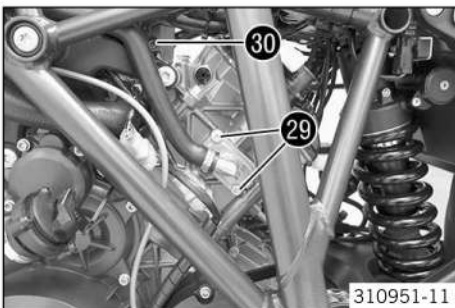

310951-11

- Position SAS cover.
- Mount and tighten screws 29.

Guideline

Remaining screws, engine	M6	10 Nm (7.4 lbf ft)
--------------------------	----	--------------------

- Position the wiring harness.
- Mount and tighten screw 30.

Guideline

Remaining screws, chassis	M5	5 Nm (3.7 lbf ft)
---------------------------	----	-------------------

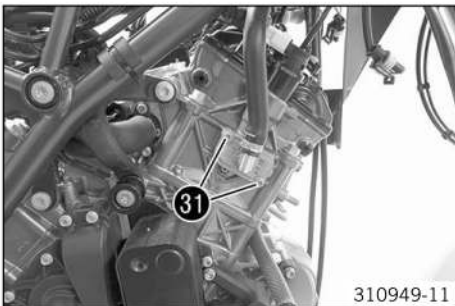

310949-11

- Mount the cable tie(s).
- Position the SAS cover.
- Mount and tighten screws 31.

Guideline

Remaining screws, engine	M6	10 Nm (7.4 lbf ft)
--------------------------	----	--------------------

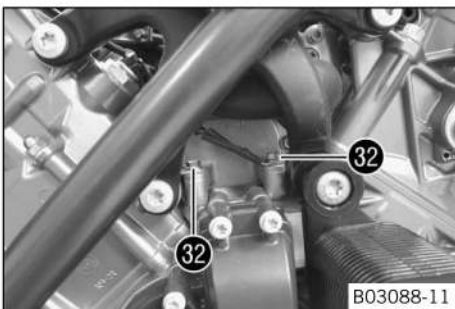

B03088-11

- Position the ground wire.
- Mount and tighten screws 32.

Guideline

Screw, starter motor	M6	10 Nm (7.4 lbf ft)
----------------------	----	--------------------



B03087-11

- Position the wiring harness.
- Mount and tighten screw 33.

Guideline

Remaining screws, chassis	M5	5 Nm (3.7 lbf ft)
---------------------------	----	-------------------

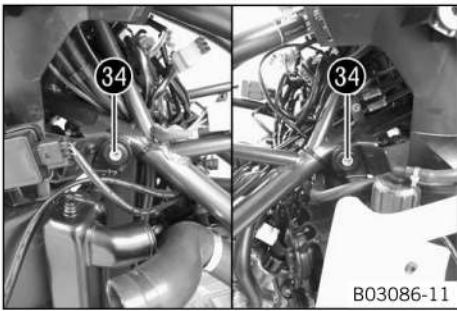

- Position the radiator.
- Mount and tighten screws 34.

Guideline

Remaining chassis screws	M6	10 Nm (7.4 lbf ft)
--------------------------	----	--------------------

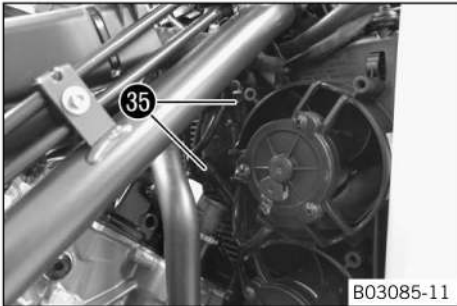

- Plug in both connectors 35 and position them in the holder.

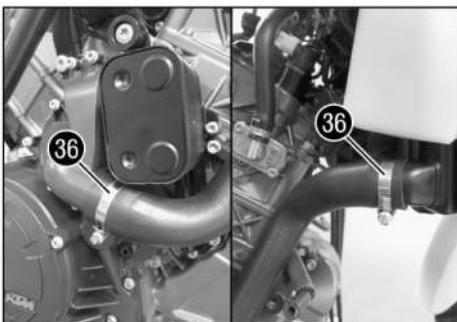

- Mount the radiator hoses.
- Position and tighten hose clips 36.
- Mount the cable tie(s).

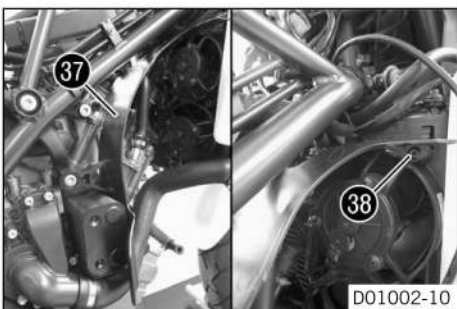

- Position heat protector 37.
- Mount and tighten screw 38.

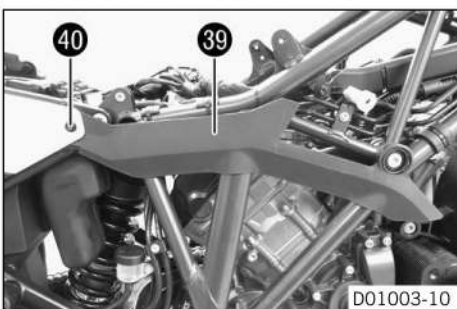

- Position heat protector 39.
- Mount and tighten screw 40.

Guideline

Screw, cover part	M5	3.5 Nm (2.58 lbf ft)
-------------------	----	-------------------------



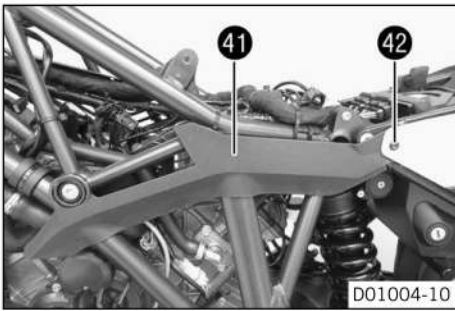

D01004-10

- Position heat protector 41.
- Mount and tighten screws 42.

Guideline

Screw, cover part	M5	3.5 Nm (2.58 lbf ft)
-------------------	----	-------------------------

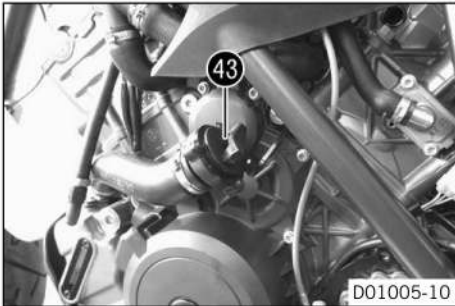

D01005-10

- The oil must be added in two steps.

Engine oil	3.60 l (3.8 qt.)	Outside temperature: $\geq 0\text{ }^{\circ}\text{C}$ ( $\geq 32\text{ }^{\circ}\text{F}$ )	Engine oil (SAE 10W/50) (p. 338)
		Outside temperature: $< 0\text{ }^{\circ}\text{C}$ ( $< 32\text{ }^{\circ}\text{F}$ )	Engine oil (SAE 5W/40) (p. 338)

- Remove screw plug 43 and fill in engine oil.

Engine oil (1st quantity) approx.	3.0 l (3.2 qt.)	Outside temperature: $\geq 0\text{ }^{\circ}\text{C}$ ( $\geq 32\text{ }^{\circ}\text{F}$ )	Engine oil (SAE 10W/50) (p. 338)
		Outside temperature: $< 0\text{ }^{\circ}\text{C}$ ( $< 32\text{ }^{\circ}\text{F}$ )	Engine oil (SAE 5W/40) (p. 338)

- Mount screw plug 43.

**Finishing work**

- Install the throttle valve body. (p. 293)
- Install the lower part of the air filter box. (p. 69)
- Install the upper part of the air filter box. (p. 67)
- Add coolant/bleed the cooling system. (p. 257)
- Install the manifold. (p. 63)
- Install the main silencer. (p. 60)
- Install the engine guard. (p. 43)
- Install the fuel tank. (p. 74)
- Install the mask spoiler. (p. 92)
- Install the tank cover. (p. 89)
- Install the front side cover. (p. 87)
- Install the crash bar. (p. 32)
- Connect the negative cable of the battery. (p. 127)
- Mount the front rider's seat. (p. 71)
- Mount the passenger seat. (p. 72)
- Set the time and date.



**Danger**

**Danger of poisoning** Exhaust gases are toxic and inhaling them may result in unconsciousness and death.

- Always make sure there is sufficient ventilation when running the engine.
- Use an effective exhaust extraction system when starting or running the engine in an enclosed space.

- Start the engine.
- Remove the screw plug and add the remaining engine oil up to the upper marking on the engine oil level viewer.
- Mount the screw plug.
- Program the swing angle sensor. (p. 59)
- Execute the initialization run. (p. 294)

- Check the lubrication system for leaks.
- Check the cooling system for leaks.
- Go for a short test ride.
- Read out the fault memory using the KTM diagnostics tool.
- Check the engine oil level. (📖 p. 276)
- Check the coolant level in the compensating tank. (📖 p. 254)

## 18.3 Preparing the engine for installation

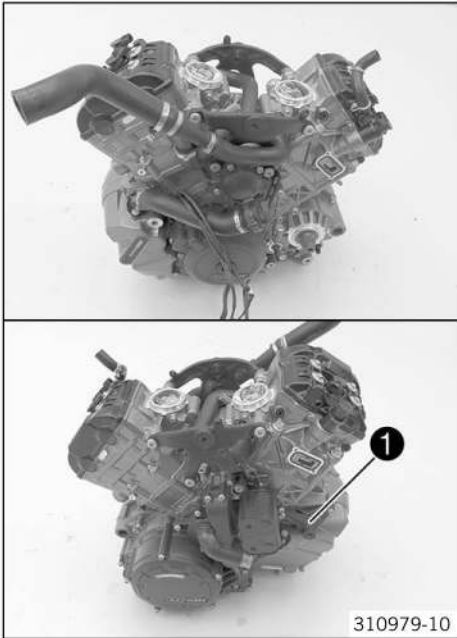

- Position both radiator hoses. Position and tighten the hose clips.
- Position the bleeder hoses.
- Remove engine fixing arm **1**.

Engine fixing arm (61230066100)

- Mount the engine fixing arm.

Engine fixing arm (60303006000)

- Mount and tighten the screws.

Guideline

Engine brace screws	M8	20 Nm (14.8 lbf ft)	Loctite® 243™
---------------------	----	------------------------	---------------

## 18.4 Preparing the engine for clamping in the engine assembly stand

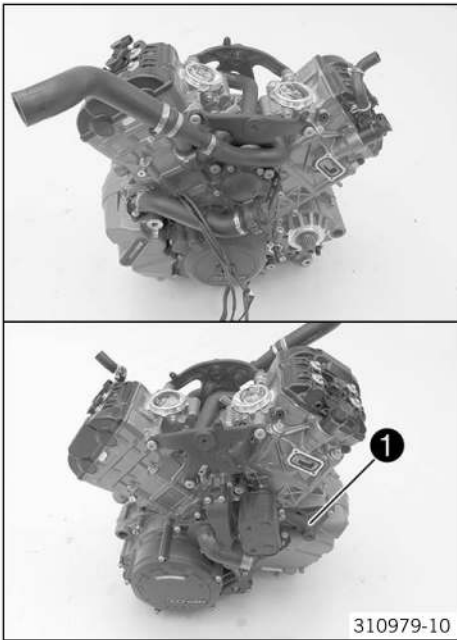

- Remove the hose clips.
- Remove both radiator hoses.
- Remove the bleeder hoses.
- Mount the engine fixing arm **1**.

Engine fixing arm (61230066100)

## 18.5 Setting the engine to ignition top dead center of the rear cylinder

**Condition**

The valve cover has been removed.

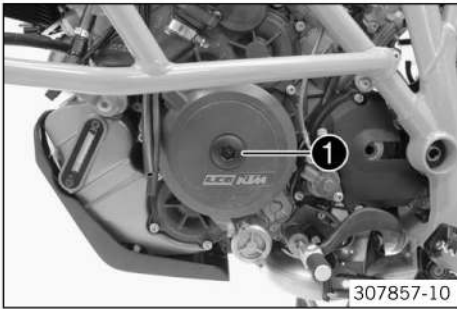

- Remove screw **1** of the alternator cover.

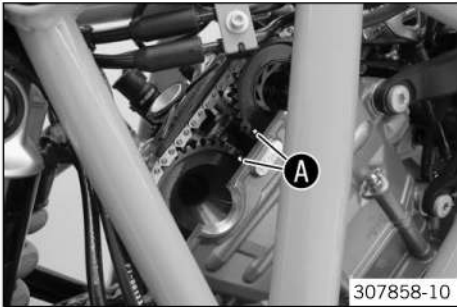

- Turn the crankshaft counterclockwise until markings **A** are flush with the edge of the cylinder head.

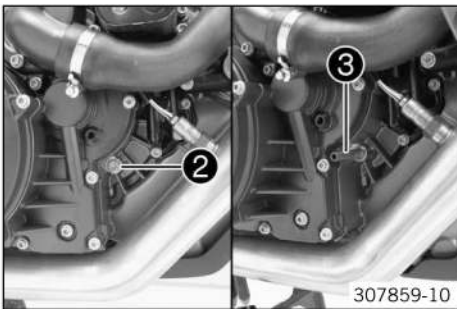

- Remove screw **2** with the washer.
- Look through the hole to check that the position notch of the crankshaft is visible.
- Screw in special tool **3**.

Engine blocking screw (61229015000) (p. 349)

## 18.6 Setting the engine to ignition top dead center of the front cylinder

**Condition**

The engine is positioned at ignition top dead center of the rear cylinder.

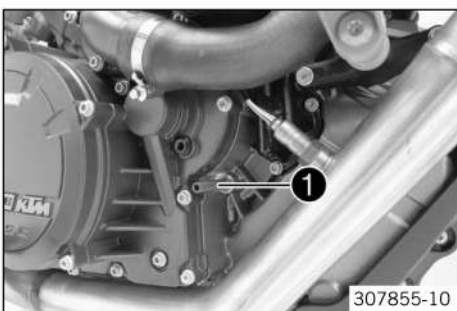

- Loosen special tool **1** by several turns.

Engine blocking screw (61229015000) (p. 349)



- Keep turning the crankshaft counterclockwise until markings **A** are flush with the edge of the cylinder head.
- Screw special tool **1** back in.

## 18.7 Engine disassembly

### 18.7.1 Clamping the engine into the engine assembly stand

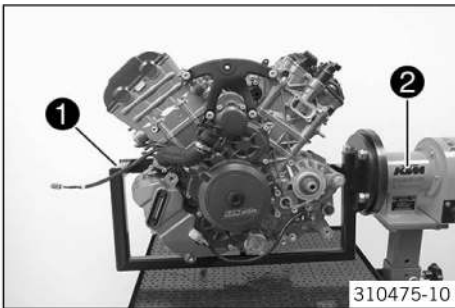

#### Preparatory work

- Prepare the engine for clamping in the engine assembly stand. (p. 168)

#### Main work

- Mount special tool ① on engine work stand ②.

Engine assembly stand (61229001000) (p. 348)

Engine fixing arm (61229002000) (p. 348)

- Mount the engine on special tool ①.



#### Info

Have an assistant help you or use a crane.

### 18.7.2 Removing the engine bearer

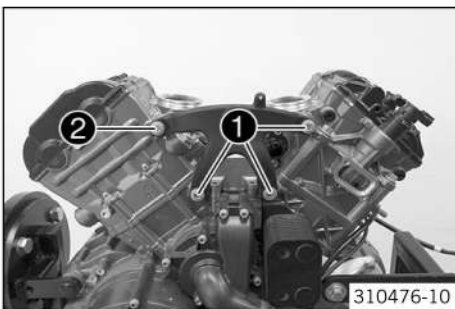

- Remove screws ①.
- Remove screw ② and take off the engine bearer.

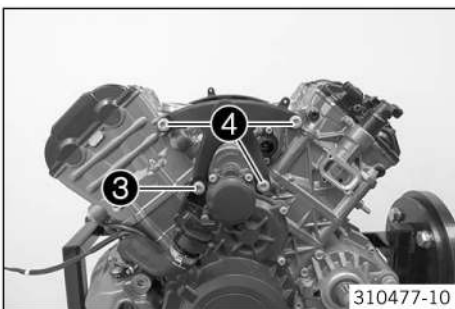

- Remove screws ③.
- Swivel oil filler tube to the side slightly.
- Remove screw ④ and take off the engine bearer.

### 18.7.3 Draining the engine oil

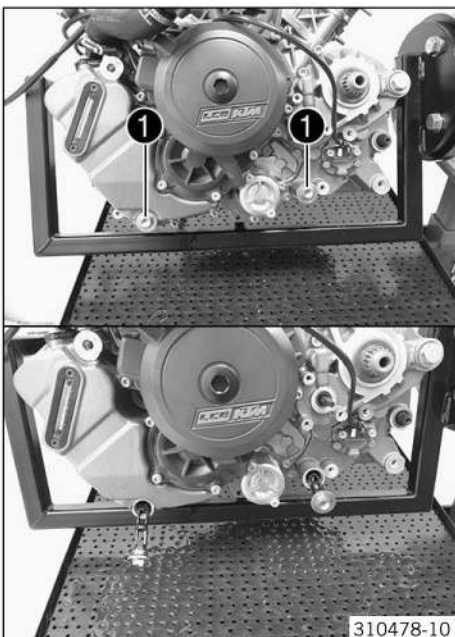

- Remove oil drain plug ① with the magnet, O-rings and oil screen.
- Completely drain the engine oil.

## 18.7.4 Removing the front valve cover

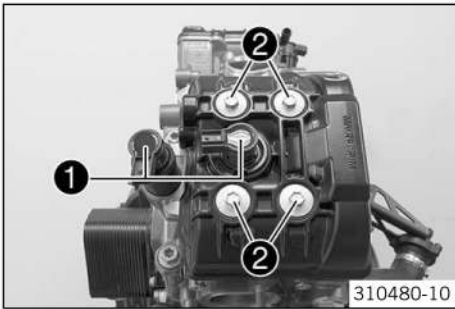

- Remove ignition coils **1**.
- Remove screws **2**. Take off the valve cover with the valve cover seal.
- Remove the spark plugs using the special tool.

Spark plug wrench (75029172000) (📖 p. 353)

## 18.7.5 Removing the rear valve cover

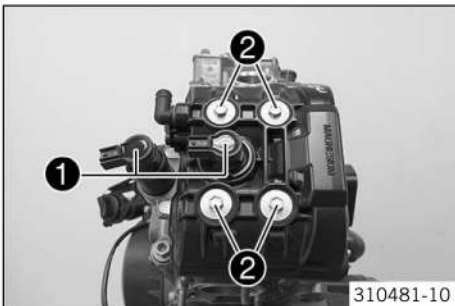

- Remove ignition coils **1**.
- Remove screws **2**. Take off the valve cover with the valve cover seal.
- Remove the spark plugs using the special tool.

Spark plug wrench (75029172000) (📖 p. 353)

## 18.7.6 Setting the engine to ignition top dead center of the rear cylinder

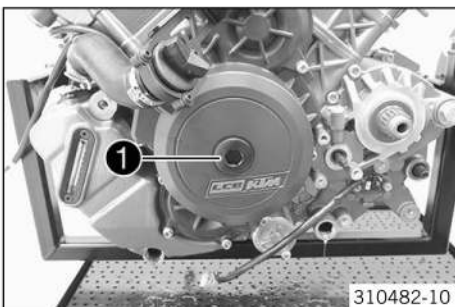

- Remove screw **1** of the alternator cover.

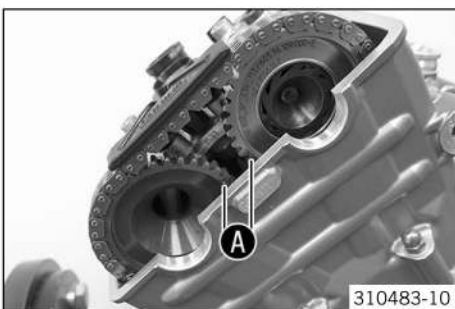

- Turn the crankshaft counterclockwise until markings **A** of the rear camshafts are flush with the edge of the cylinder head.

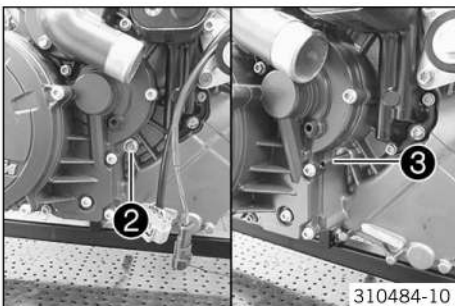

- Remove screw **2**.
- Look through the hole to check that the position notch of the crankshaft is visible.
- Screw in special tool **3**.

Engine blocking screw (61229015000) (📖 p. 349)

## 18.7.7 Removing the starter motor

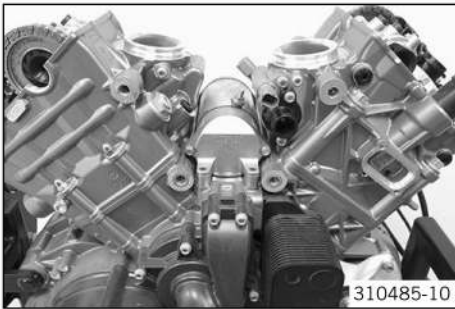

- Take off the starter motor.

## 18.7.8 Removing the oil filler tube

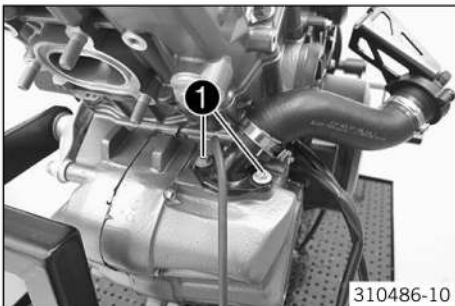

- Remove screws ①.
- Remove the oil filler tube with the O-ring.

## 18.7.9 Removing the heat exchanger

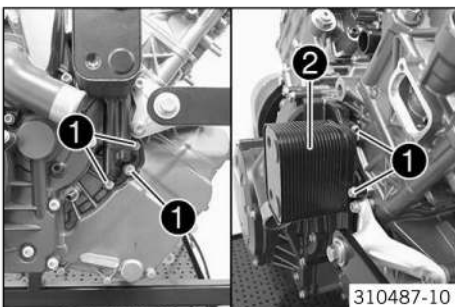

- Remove screws ① of heat exchanger ②.
- Remove the heat exchanger.

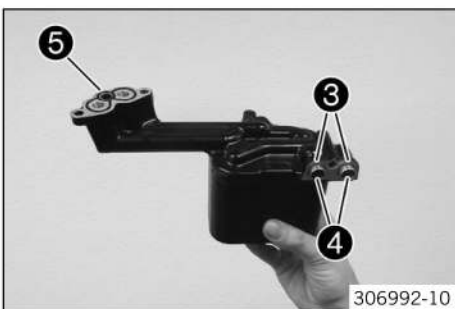

- Remove O-rings ③ and sleeves ④.
- Remove seal ⑤.

## 18.7.10 Removing the rear timing chain tensioner

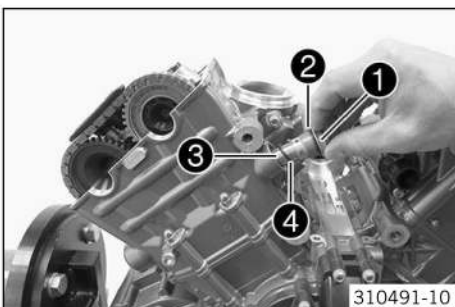

- Remove screw ① with O-ring ②.
- Remove timing chain tensioner ③ with O-ring ④.

## 18.7.11 Removing the rear camshaft

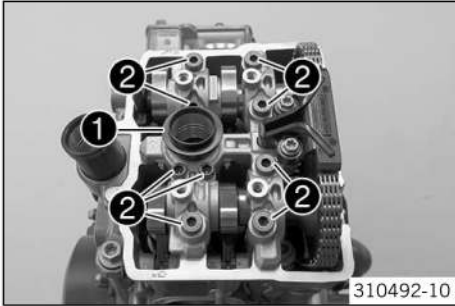

- Remove spark plug shaft insert **1**.
- Loosen and remove screws **2** from the outside to the inside.



### Info

The cams should not activate the valves.

- Remove the camshaft bearing bridge.

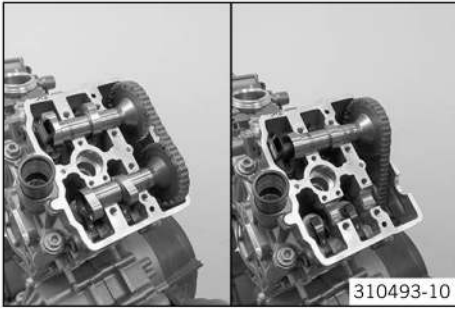

- Raise the camshaft at the rear and take the timing chain off of the rear sprocket. Remove the camshaft.

## 18.7.12 Removing the rear cylinder head

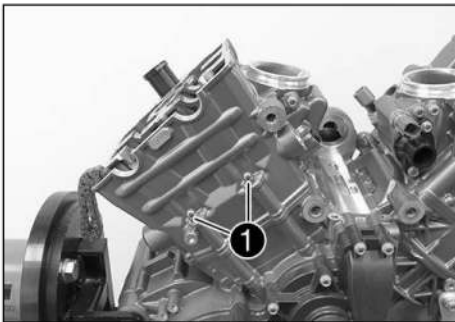

- Remove nuts **1** with the washers.
- Alternately loosen screws **2** and remove them.
- Take off the cylinder head.

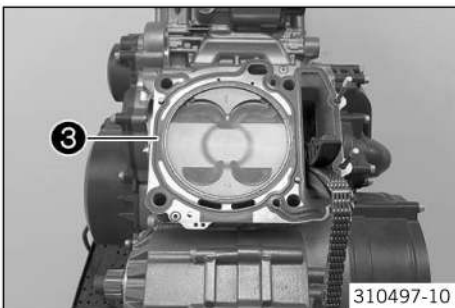
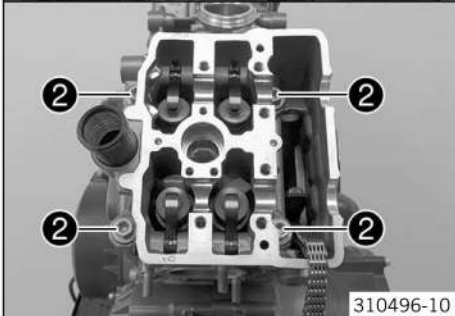

- Remove cylinder head gasket **3**.

## 18.7.13 Removing the rear piston



- Push the cylinder up.



### Info

Push the cylinder up until the piston pin can be removed. Make sure that the two pins remain in place.

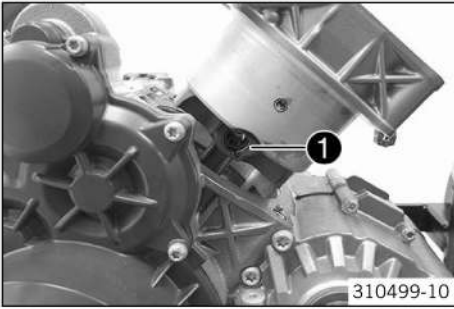

- Remove piston pin retainer **1**.
- Remove the piston pin.
- Remove the cylinder with the piston.
- Push the piston upward out of the cylinder.



### Info

If no additional work needs to be performed on the cylinder and piston, the piston can remain in the cylinder.

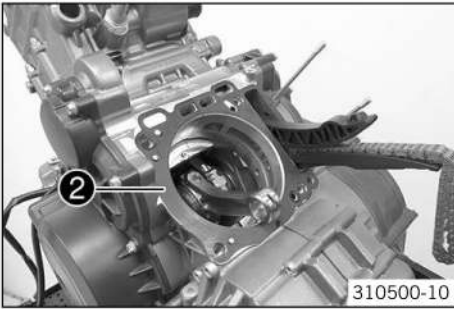

- Remove cylinder base gasket **2**.

## 18.7.14 Setting the engine to ignition top dead center of the front cylinder

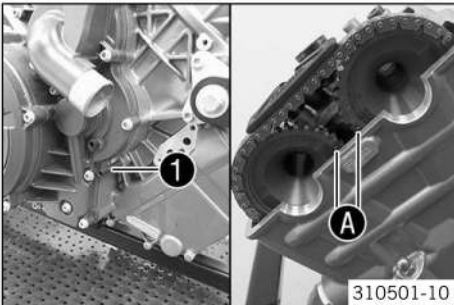

- Loosen special tool **1** by several turns.

Engine blocking screw (61229015000) (p. 349)

- Keep the timing chain taut. Hold the connecting rod in the center of the drill hole.
- Keep turning the crankshaft counterclockwise until markings **A** of the front camshafts are flush with the edge of the cylinder head.
- Screw special tool **1** back in.

## 18.7.15 Removing the front timing chain tensioner

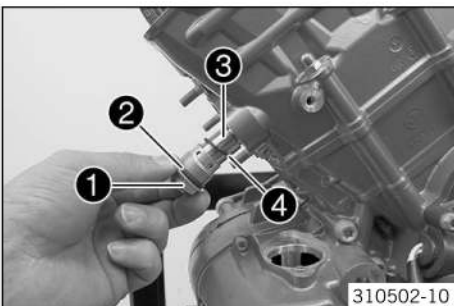

- Remove screw **1** with O-ring **2**.
- Remove timing chain tensioner **3** with O-ring **4**.



## 18.7.16 Removing the front camshafts

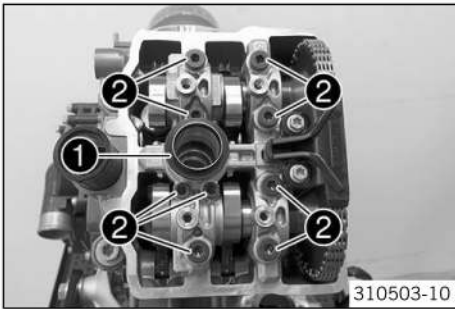

310503-10

- Remove spark plug shaft insert **1**.
- Loosen and remove screws **2** from the outside to the inside.



### Info

The cams should not activate the valves.

- Remove the camshaft bearing bridge.

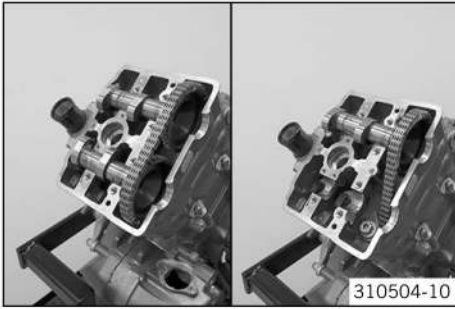

310504-10

- Raise the camshaft at the rear and take the timing chain off of the rear sprocket. Remove the camshaft.

## 18.7.17 Removing the front cylinder head

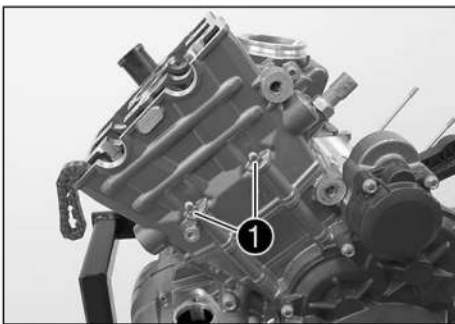

- Remove nuts **1** with the washers.
- Alternately loosen screws **2** and remove them.
- Remove the cylinder head.

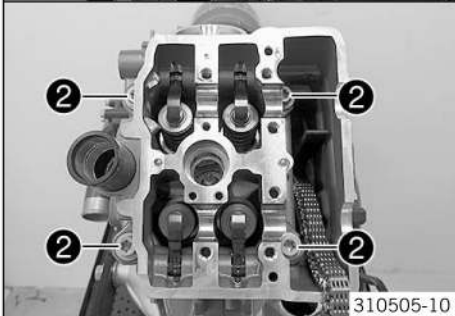

310505-10

- Remove cylinder head gasket **3**.

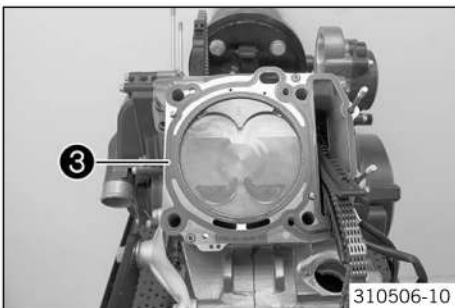

310506-10

## 18.7.18 Removing the front piston



- Push the cylinder up.



### Info

Push the cylinder up until the piston pin can be removed. Make sure that the two pins remain in place.

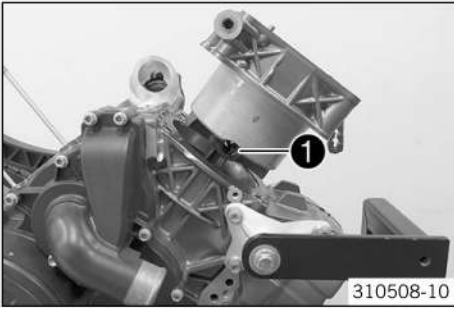

- Remove piston pin retainer **1**.
- Remove the piston pin.
- Remove the cylinder with the piston.
- Push the piston upward out of the cylinder.



### Info

If no additional work needs to be performed on the cylinder and piston, the piston can remain in the cylinder.

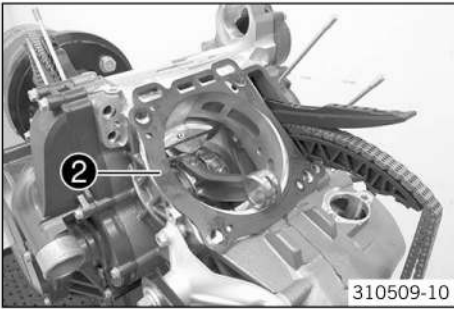

- Remove cylinder base gasket **2**.

## 18.7.19 Removing the alternator cover

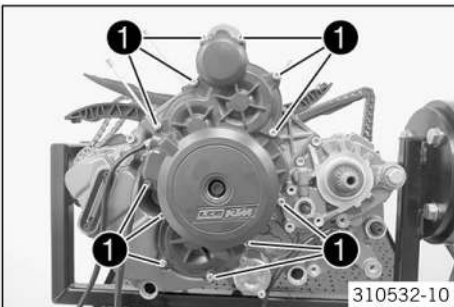

- Remove screws **1**.

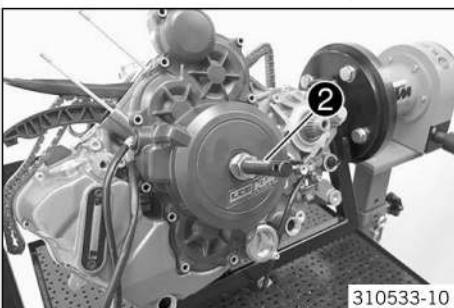

- Screw in special tool **2** and pull off the alternator cover.

Extractor (61229010000) ( p. 349)



### Info

Strike the alternator cover lightly with a rubber mallet to prevent strain.

- Take off the alternator cover seal. Take off the dowels.

## 18.7.20 Removing the ignition pulse generator

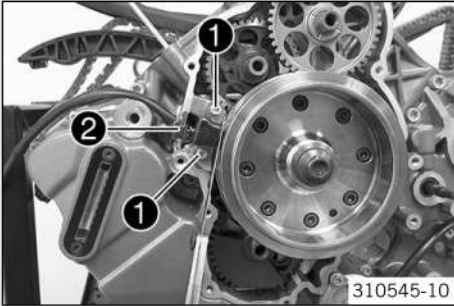

- Remove the screws of ignition pulse generator ❶.
- Pull cable support sleeve ❷ out of the engine case. Take off the ignition pulse generator.

## 18.7.21 Removing the torque limiter

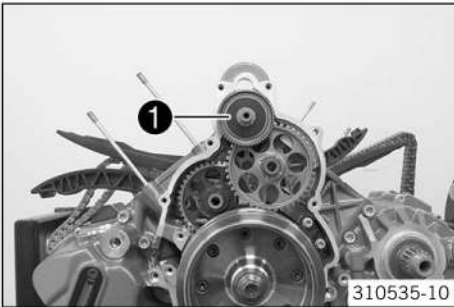

- Take off torque limiter ❶.

## 18.7.22 Removing the rotor

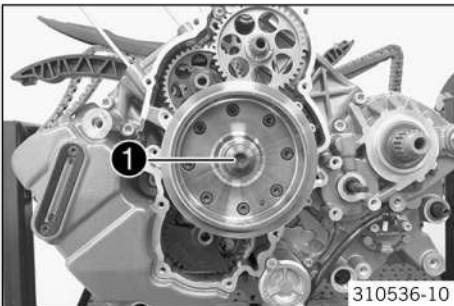

- Loosen and remove screw ❶ of the rotor.



### Info

The crankshaft must be blocked.

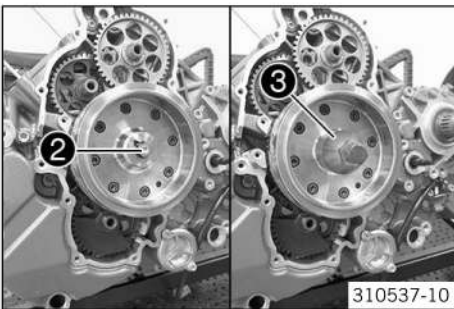

- Screw special tool ❷ into the crankshaft.

Pressure piece (61229008100) (📖 p. 348)

- Mount special tool ❸ on the rotor, apply counterpressure, and pull off the rotor by screwing in the screw.

Extractor (75029021000) (📖 p. 353)

- Remove the special tools.

## 18.7.23 Removing the idler and timing chain on the left

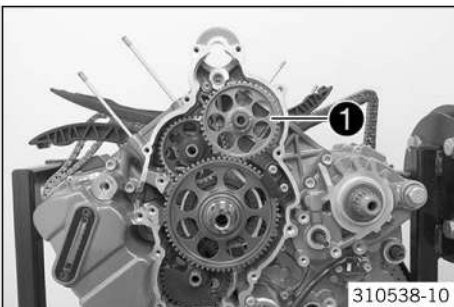

- Remove idler ❶ with the washers and needle bearing.

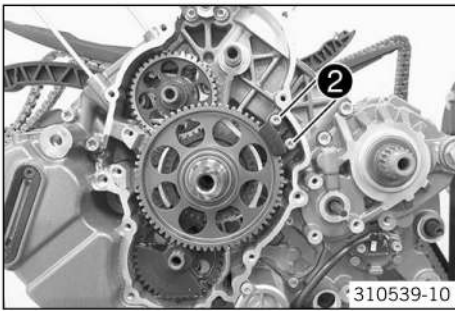

- Remove screws ② and take off freewheel holder.

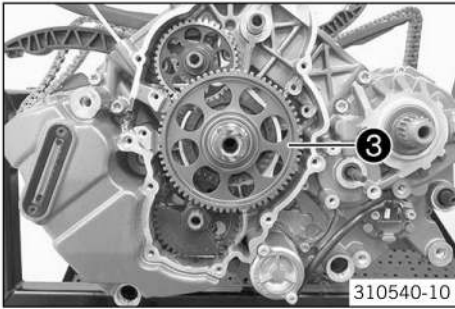

- Remove freewheel gear ③.

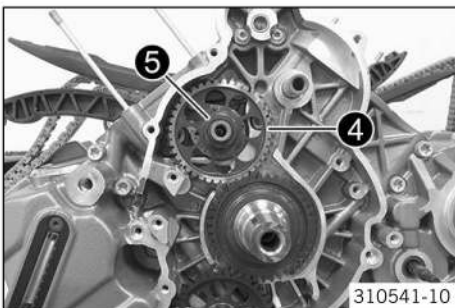

- Take off idler ④ with washer ⑤.



**Info**

For easier disassembly, loosen the engine blocking screw.

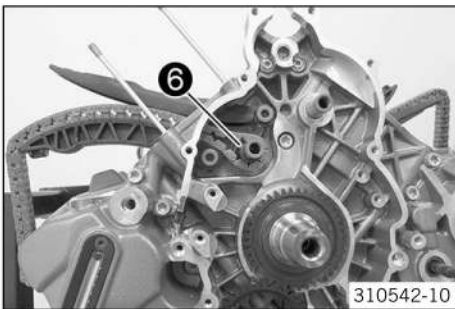

- Remove the timing chain, needle bearing ⑥ and the washer lying behind it.



**Info**

If the timing chain is to be used again, note the direction of travel and the cylinder on which it was used.

## 18.7.24 Removing the oil filter

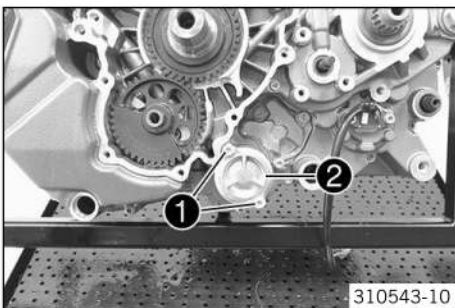

- Remove screws ①. Take off oil filter cover ② with the O-ring.

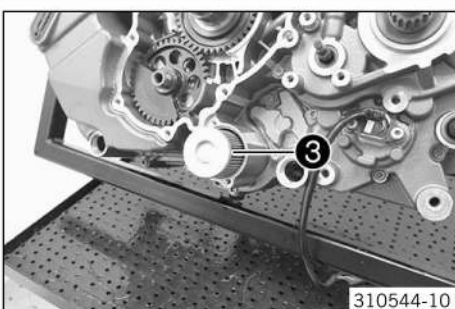

- Pull oil filter ③ out of the oil filter housing.

Circlip pliers reverse (51012011000) (📖 p. 344)

## 18.7.25 Removing the balancer shaft

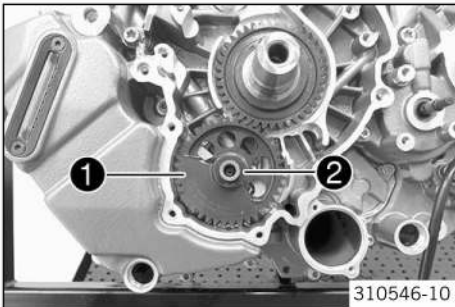

- Remove balancer shaft **1** with washer **2**.
- Mount the needle bearing and the rear washer.

## 18.7.26 Removing the drive wheel of the balancer shaft

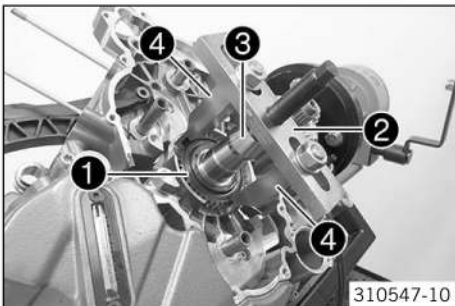

- Remove drive wheel **1** of the balancer shaft with special tool **2**, **3** and **4**.

Puller, 2-arm (78029033100) (p. 354)
--------------------------------------

Pressure piece (61229018000) (p. 350)
---------------------------------------

Arms for extractor 78029033100 (61229017000) (p. 349)
---

## 18.7.27 Removing the gear position sensor

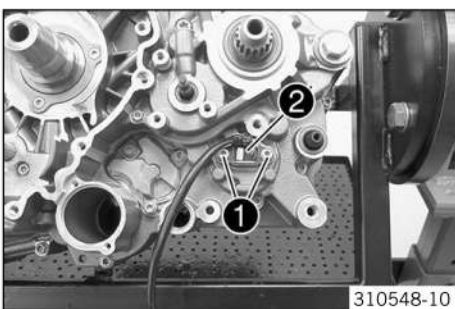

- Remove screws **1** with the washers.
- Remove gear sensor **2**.

## 18.7.28 Removing the left suction pump

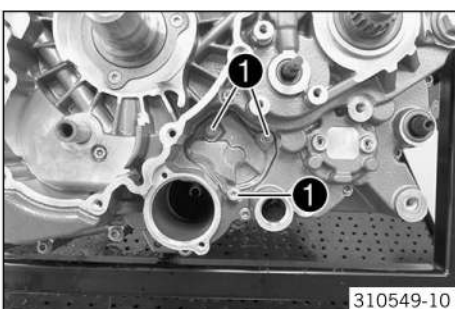

- Remove screws **1**.

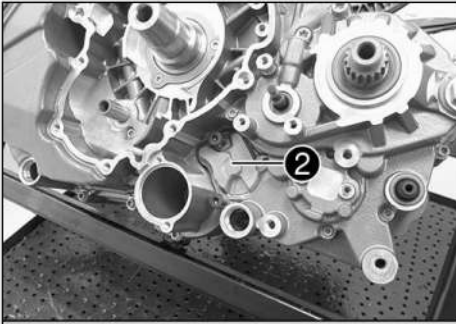

- Screw suitable screws into the oil pump cover.
- Remove the oil pump cover by screwing in the screws.
- Remove oil pump cover **2**.
- Remove gasket **3**.

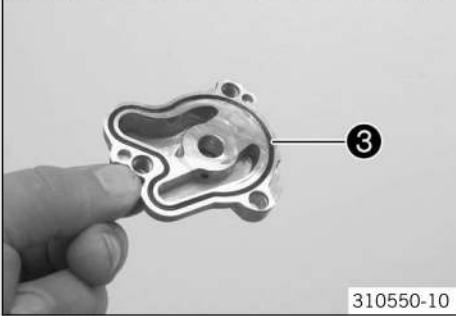

310550-10

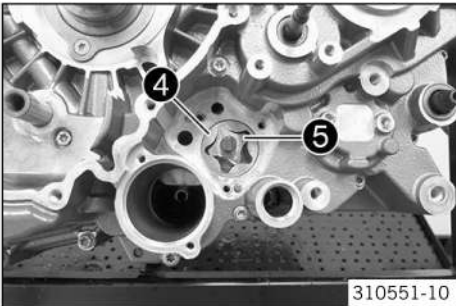

- Remove external rotor **4** and internal rotor **5**.

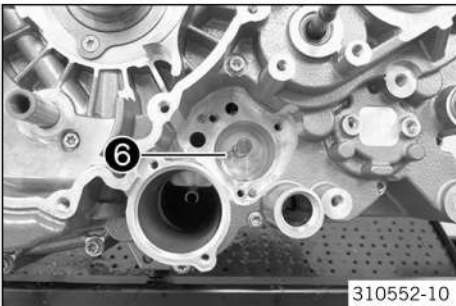

- Remove pin **6**.

310552-10

## 18.7.29 Removing the water pump wheel

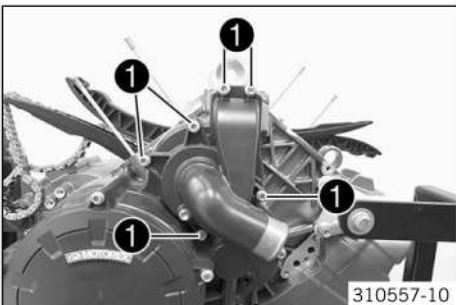

- Remove screws **1**.
- Take off the water pump cover.

310557-10

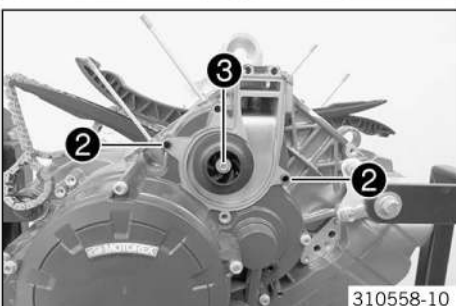

- Remove dowels **2**.
- Remove screw **3**. Take off the water pump wheel with the washer below it.

310558-10

## 18.7.30 Removing the clutch cover

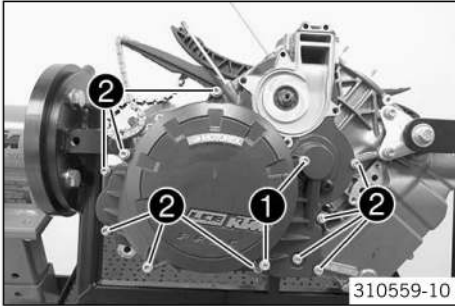

- Loosen screws **1** of the outer clutch cover.
- Remove screws **2**.
- Take off the clutch cover.

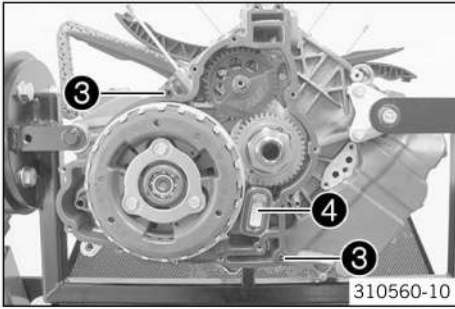

- Take off dowels **3**. Remove the clutch cover seal.
- Remove check valve **4**.

## 18.7.31 Removing the clutch discs

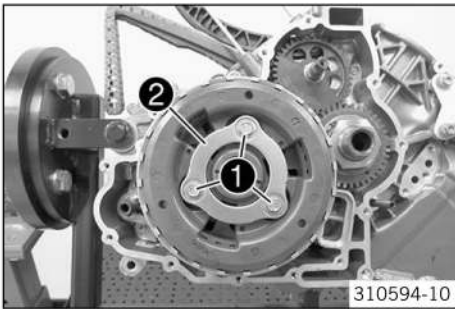

- Remove screws **1**.
- Take off clutch center **2** and the springs.

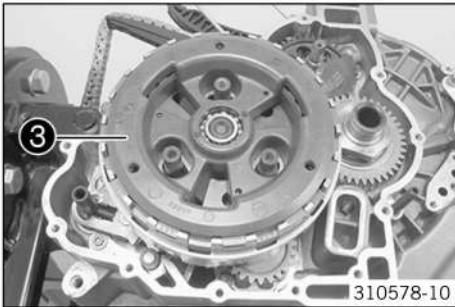

- Remove clutch pressure cap **3**.

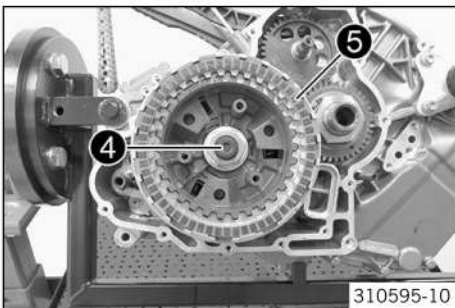

- Remove push rod **4**.
- Remove clutch discs **5**, support ring, and pretension ring.

## 18.7.32 Removing the clutch basket

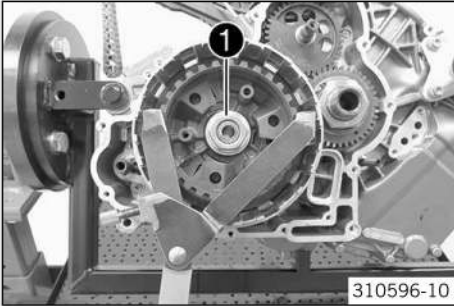

- Hold the inner clutch hub with the special tool.

Clutch holder (51129003000) (📖 p. 344)

- Remove nut **1** with the washer.

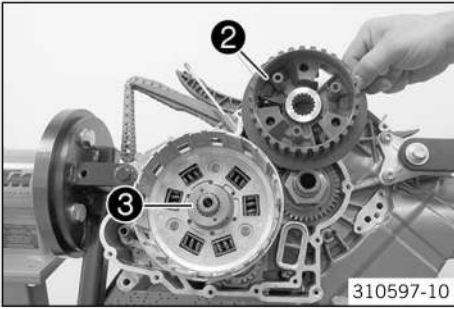

- Take off inner clutch hub **2** and washer **3**.



**Info**

The washer usually sticks to the inner clutch hub.

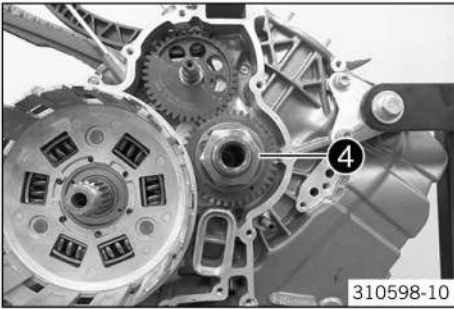

- Loosen nut **4** of the primary gear and remove it with the washer.



**Info**

Left-handed thread!

Make sure that the crankshaft is blocked.

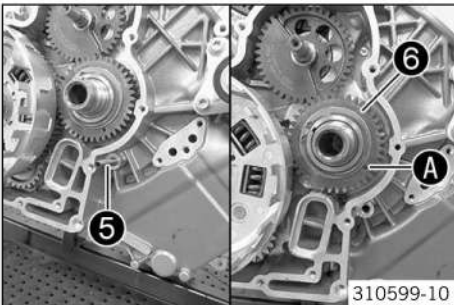

- Remove the special tool **5**.

Engine blocking screw (61229015000) (📖 p. 349)

- Keep the timing chain taut. Hold the both connectings rod in the center of the drill hole.

- Turn primary gear **6** counterclockwise.

✓ Hole **A** is accessible.

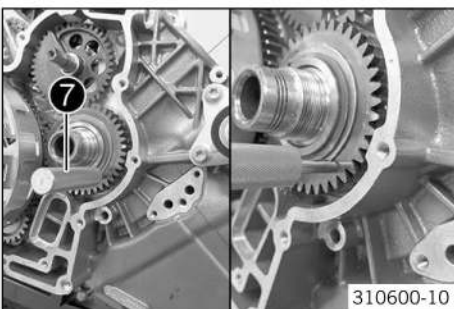

- Mount special tool **7** until it stops.

Spread transmission locking pin (61329033000) (📖 p. 352)

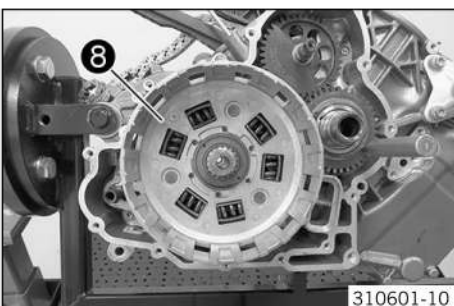

- Remove clutch basket **8** with oil pump drive gear.



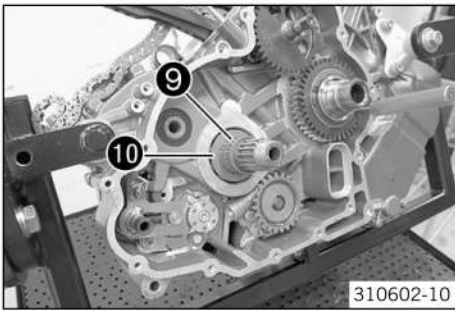

- Remove needle bearing ⑨ and washer ⑩.

### 18.7.33 Removing the idler and timing chain on the right

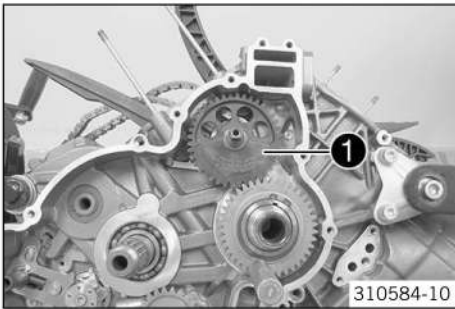

- Remove idler ①.
- Take off the timing chain.



**Info**

If the timing chain is to be used again, note the direction of travel and the cylinder on which it was used.

### 18.7.34 Removing the primary gear

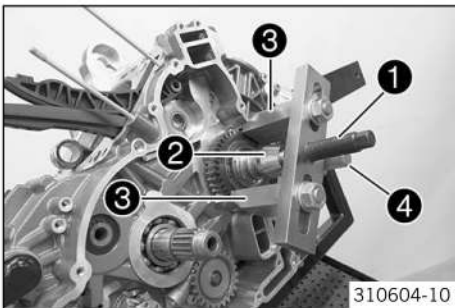

- Remove the primary gear with special tool ①, ② and ③.

Puller, 2-arm (78029033100) (📖 p. 354)
Pressure piece (61229018000) (📖 p. 350)
Arms for extractor 78029033100 (61229017000) (📖 p. 349)



**Warning**

**Risk of injury** Spring-loaded parts snap back.

- Disassemble spring-loaded parts taking the spring force into account (clamp in a vise).

- Do not remove special tool ④.

Spread transmission locking pin (61329033000) (📖 p. 352)
--

### 18.7.35 Removing the force pump

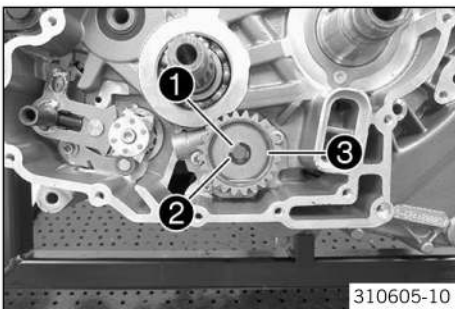

- Remove lock washer ① and washer ②.
- Remove oil pump gear wheel ③.

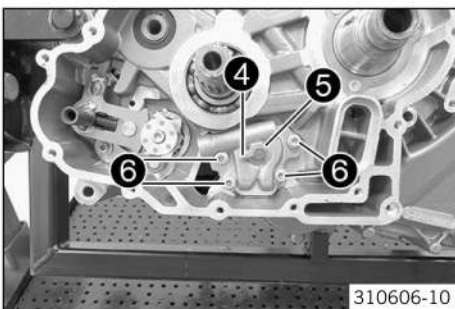

- Remove pin ④ and washer ⑤.
- Remove screws ⑥.
- Remove the oil pump cover.

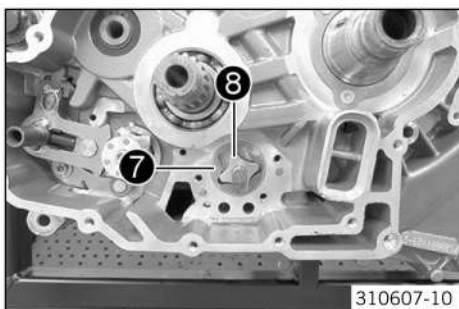

- Remove external rotor 7 and internal rotor 8.

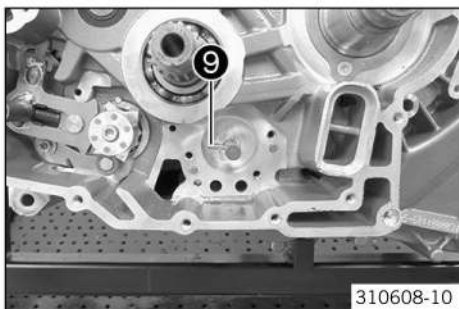

- Remove pin 9.

### 18.7.36 Removing the shift shaft

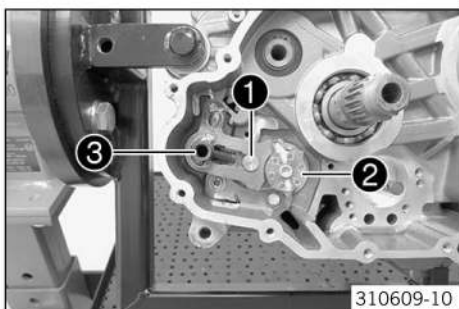

- Push sliding plate 1 away from the shift drum locating 2. Remove shift shaft 3 with the washer.

### 18.7.37 Removing the shift drum locating

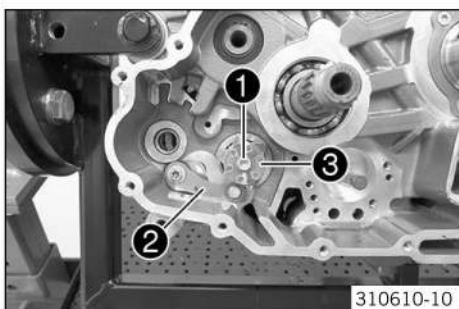

- Remove screw 1.
- Press locking lever 2 away from shift drum locating 3 and take off the shift drum locating.
- Release the locking lever.

### 18.7.38 Removing the locking lever

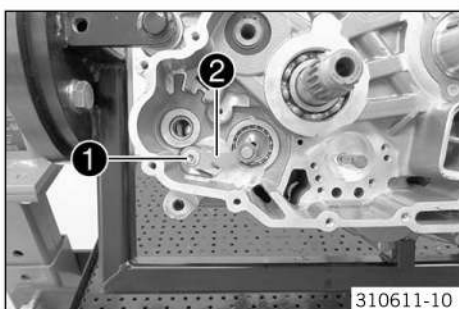

- Remove screw 1.
- Take off locking lever 2 with the sleeve and spring.

## 18.7.39 Removing the left engine case

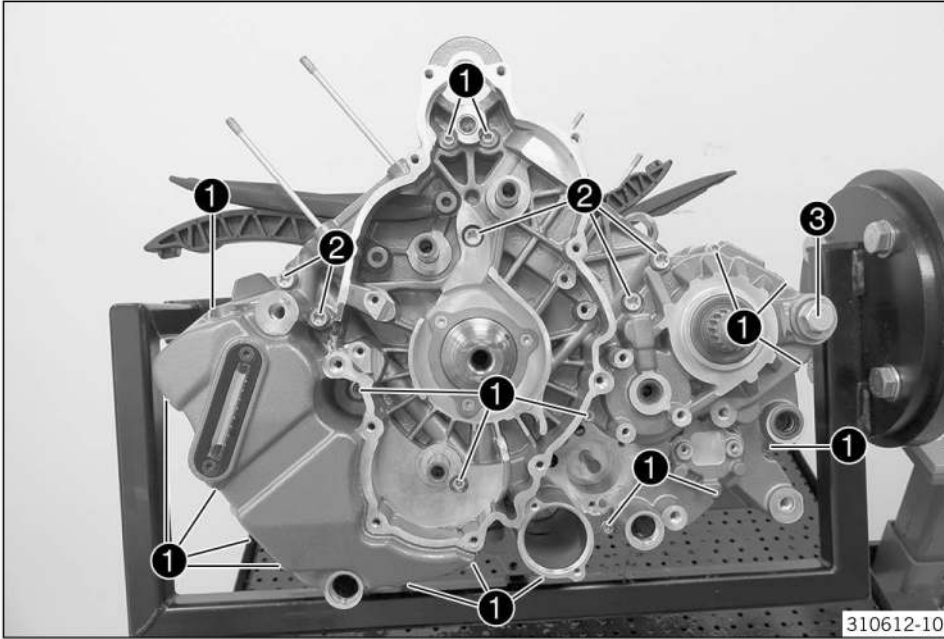

- Remove screws **1** and **2**.
- Swing the left section of the engine case upward. Remove screw **3**.
- Loosen the left section of the engine case by striking it lightly with a plastic hammer and remove it.

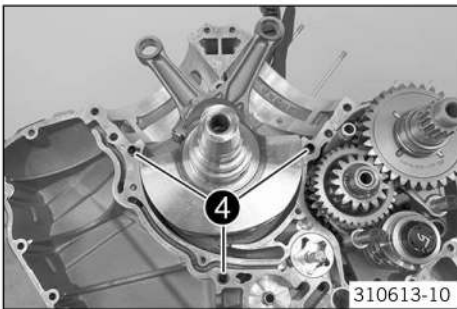

- Remove dowels **4**.

## 18.7.40 Removing the crankshaft

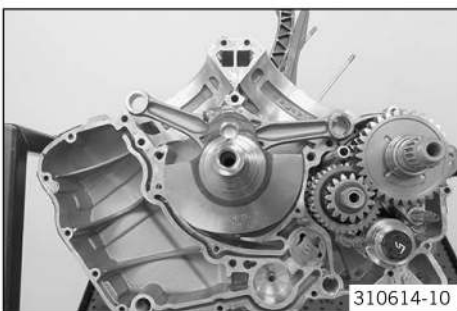

- Remove the crankshaft.

## 18.7.41 Removing the middle suction pump

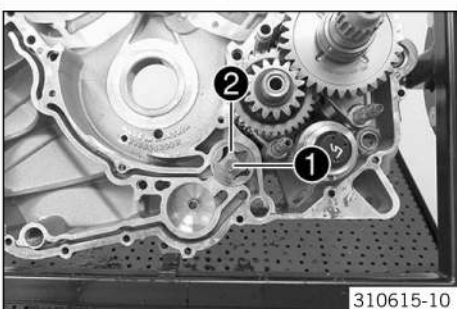

- Take off oil pump shaft **1** with internal rotor **2**.

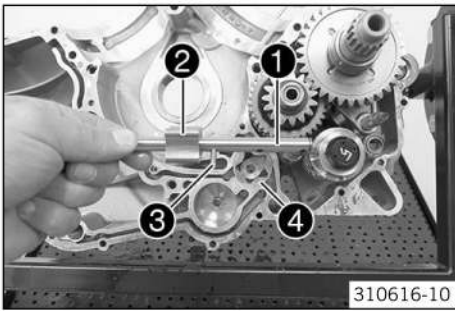

- Remove internal rotor ② and pin ③ from the oil pump shaft ①.
- Remove external rotor ④.

## 18.7.42 Removing the transmission shaft

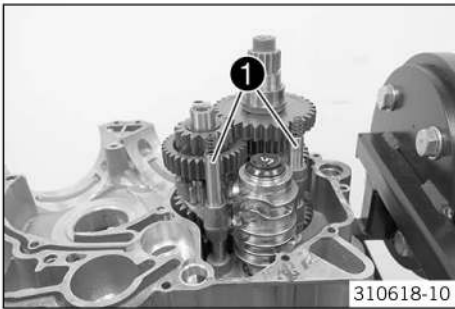

- Remove shift rails ① with the springs.

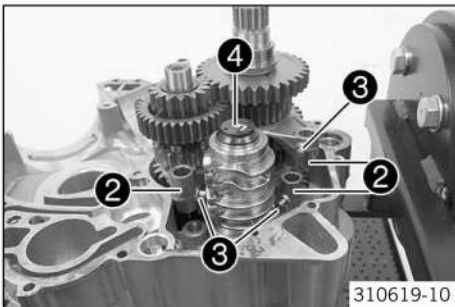

- Swing shift forks ② to one side.



**Info**

Make sure not to misplace shift rollers ③.

- Remove shift drum ④.

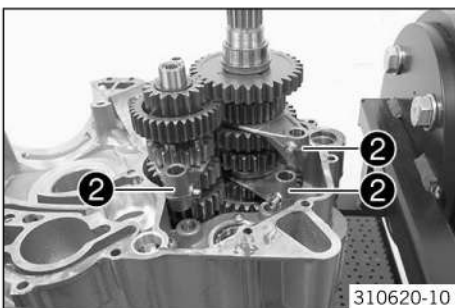

- Remove shift forks ②.



**Info**

Make sure not to misplace the shift rollers.

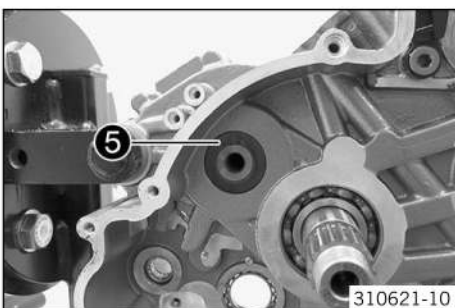

- Place the engine in an upright position.
- Remove lock ring ⑤ and the stop disk.

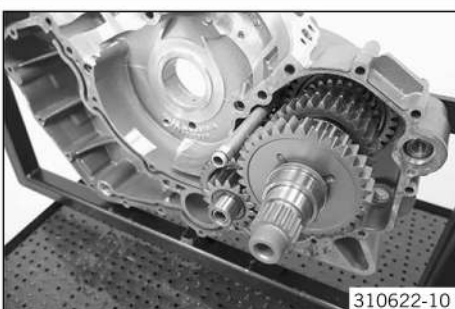

- Pull both transmission shafts out of the bearing seats together.

## 18.7.43 Removing the oil spray tube

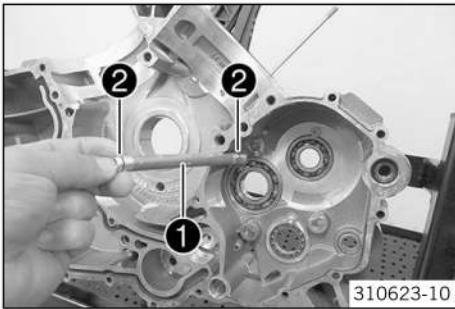

- Remove oil spray tube **1**. Remove O-rings **2**.

## 18.7.44 Removing the timing chain rails of the right engine case section

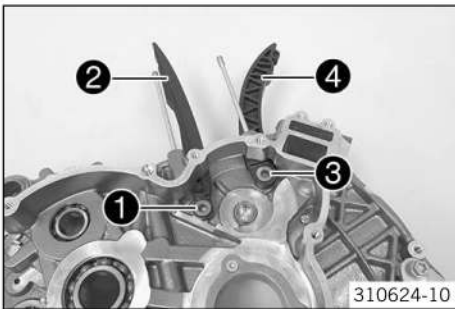

- Remove screw **1**. Remove timing chain guide rail **2**.
- Remove screw **3**. Remove timing chain tensioning rail **4**.

## 18.7.45 Removing the timing chain rails of the left engine case section

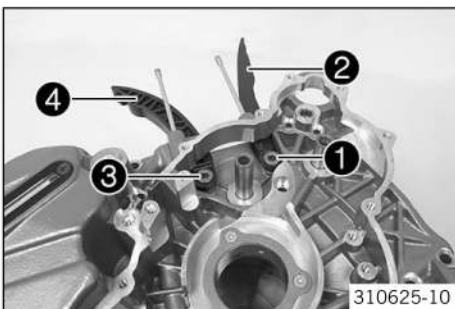

- Remove screw **1**. Remove timing chain guide rail **2**.
- Remove screw **3**. Remove timing chain tensioning rail **4**.

## 18.8 Working on individual parts

### 18.8.1 Work on the right section of the engine case

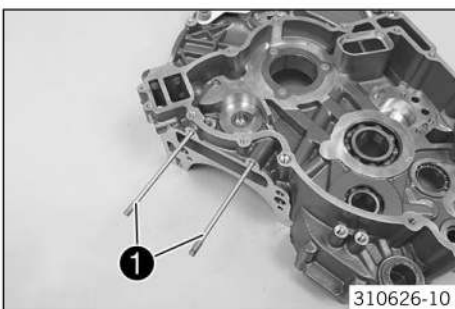

- Remove studs **1**.

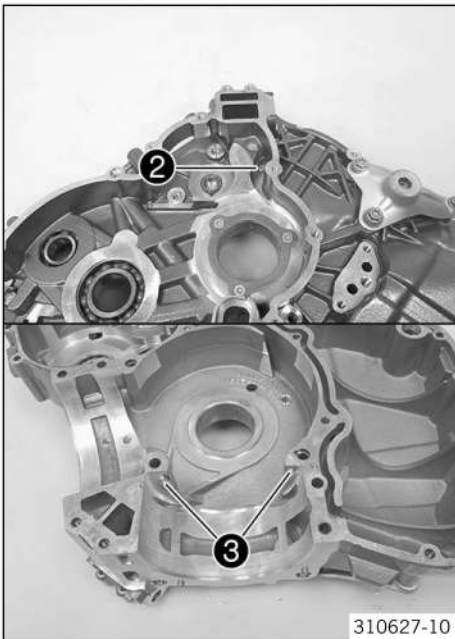

- Remove nozzle ②.
- Remove oil nozzles ③.

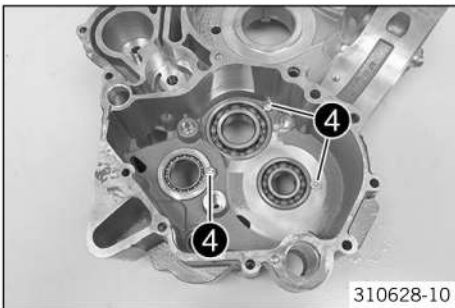

- Remove bearing retainers ④.
- Remove the dowels.
- Remove any sealing mass remnants and clean the engine case section thoroughly.
- Warm the engine case section in an oven.

**Guideline**

130 °C (266 °F)
-----------------

- Knock the engine case section against a level wooden plate. This will cause the bearings to drop out of the bearing seats.

**i Info**

Any bearings that remain in the engine case section must be removed using a suitable tool.

- Warm the engine case section again.

**Guideline**

130 °C (266 °F)
-----------------

- Insert the new cold bearings into the bearing seats of the hot engine case section and, if necessary, use a suitable press drift to push the bearing from the inside to the outside, all the way to the stop or so it is flush.

**i Info**

When pressing the bearing in, ensure that the engine case section is level to prevent damage.  
Only press the bearings in via the outer bearing race; otherwise, the bearings will be damaged when they are pressed in.

- After the engine case section has cooled, check that the bearings are firmly seated.

**i Info**

If the bearings are not firmly seated after cooling, it is likely that they will rotate in the engine case when warm. In this case, the engine case must be renewed.

- Mount and tighten bearing retainers ④.

**Guideline**

Screw, bearing retainer	M5	6 Nm (4.4 lbf ft)	<b>Loctite® 243™</b>
-------------------------	----	----------------------	----------------------

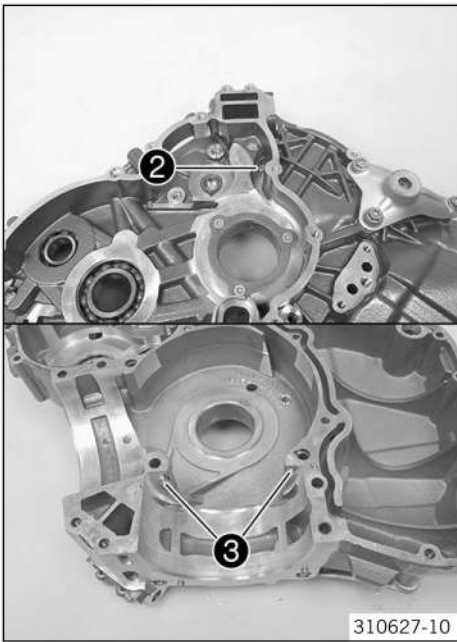

- Mount and tighten nozzle **2**.

Guideline

Nozzle 100	M6x0.75	4 Nm (3 lbf ft)	Loctite® 243™
------------	---------	--------------------	---------------

- Mount and tighten oil nozzles **3**.

Guideline

Oil nozzle	M5	2 Nm (1.5 lbf ft)	Loctite® 243™
------------	----	----------------------	---------------

- Mount the dowels.

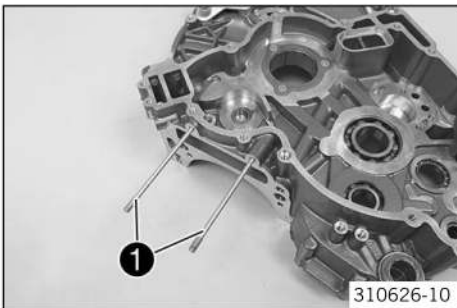

- Mount studs **1**.

Guideline

Stud, chain shaft	M6	8 Nm (5.9 lbf ft)
-------------------	----	-------------------

- Blow compressed air through all oil channels and check that they are clear.

## 18.8.2 Removing the right main bearing

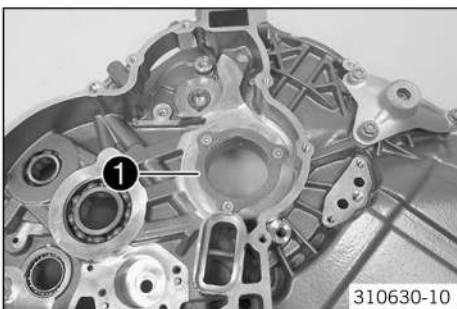

- Remove the screws and take off bearing shell bracket **1**.

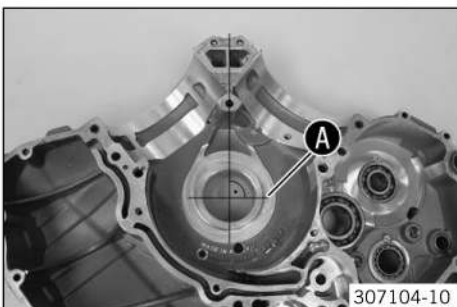

- Mark face **A** of the main bearing shells as shown in the figure.

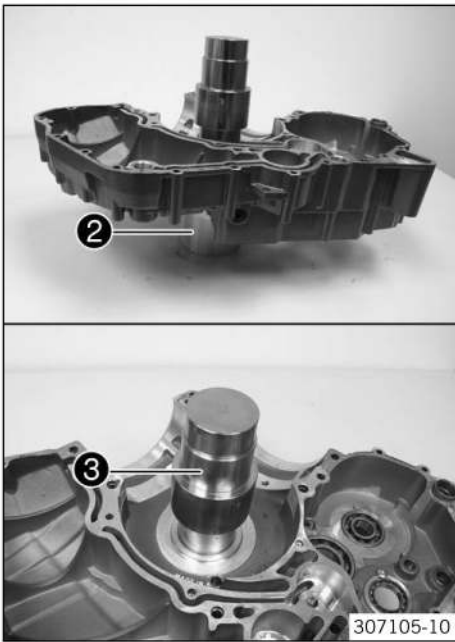

- Place the engine case section on special tool **2**.

Press sleeve (61229045000) (📖 p. 351)

- Place special tool **3** with the smaller diameter on the bearing shells and press from the inside to the outside.

Press drift/press sleeve (61229044000) (📖 p. 351)

### 18.8.3 Selecting the main bearing shells

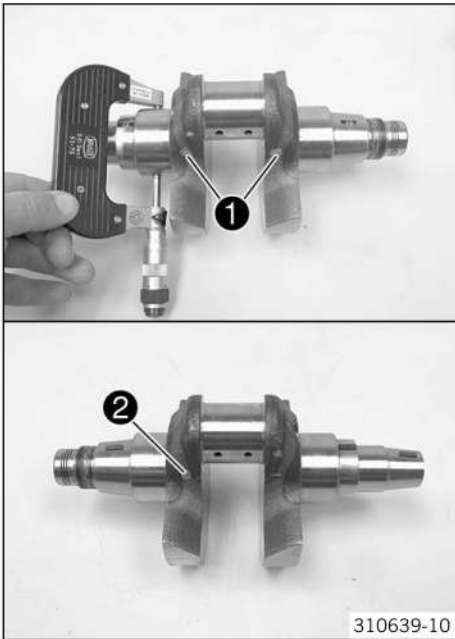

#### New crankshaft

- Select the new bearing shells according to color marking **1**.



#### Info

Color marking **2** refers to the conrod bearing.

#### Used crankshaft

- Measure both pivot points and select the new bearing shells accordingly.

#### Guideline

Crankshaft - main bearing diameter	
Yellow	52.965... 52.975 mm (2.08523... 2.08563 in)
Blue	52.976... 52.985 mm (2.08567... 2.08602 in)
Red	52.986... 52.995 mm (2.08606... 2.08641 in)

### 18.8.4 Installing the right main bearing

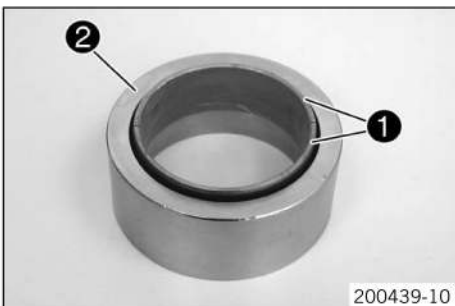

#### Preparatory work

- Select the main bearing shells. (📖 p. 190)

#### Main work

- Center the new main bearing shells **1** using special tool **2**.

Press drift/press sleeve (61229044000) (📖 p. 351)



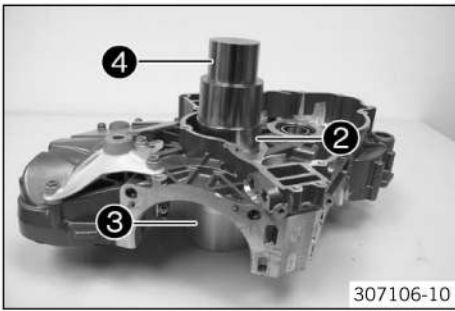

- Place the inside of the engine case section on special tool **3**.

Press sleeve (61229045000) (p. 351)

- Align the face of the new bearing shell with the marking made when it was disassembled.
- Press the bearing shells with the stepped side of special tool **4** through press sleeve **2** from the outside to the inside, all the way to the stop.

Press drift/press sleeve (61229044000) (p. 351)

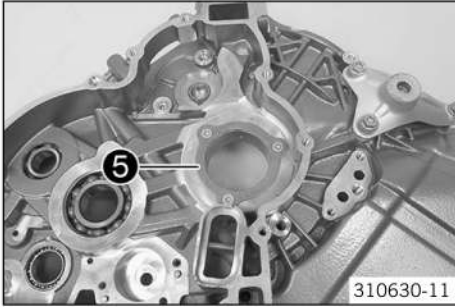

- Position bearing shell bracket **5**. Mount and tighten the screws.

Guideline

Screw, bearing retainer	M5	6 Nm (4.4 lbf ft)	Loctite® 243™
-------------------------	----	----------------------	---------------

## 18.8.5 Work on the left section of the engine case

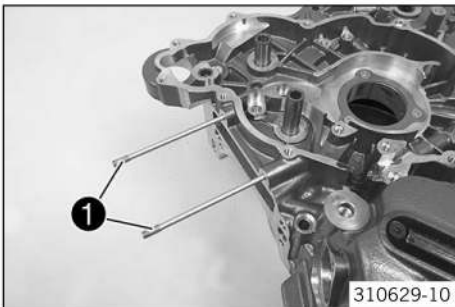

- Remove studs **1**.

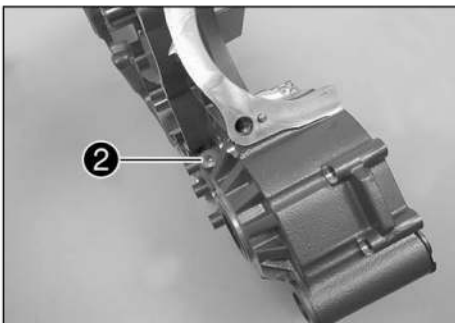

- Remove screw **2**.



- Remove oil nozzles **3**.

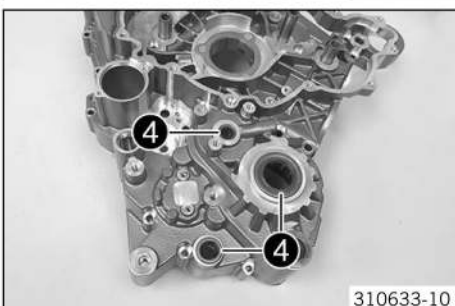

- Remove shaft seal rings **4**.
- Remove any sealing mass remnants and clean the engine case section thoroughly.
- Warm the engine case section in an oven.

Guideline

130 °C (266 °F)

- Knock the engine case section against a level wooden plate. This will cause the bearings to drop out of the bearing seats.

**i** **Info**

Any bearings that remain in the engine case section must be removed using a suitable tool.

- Warm the engine case section again.

Guideline

130 °C (266 °F)
-----------------

- Insert the new cold bearings into the bearing seats of the hot engine case section and, if necessary, use a suitable press drift to push the bearing from the inside to the outside, all the way to the stop or so it is flush.

**i** **Info**

When pressing the bearing in, ensure that the engine case section is level to prevent damage.

Only press the bearings in via the outer bearing race; otherwise, the bearings will be damaged when they are pressed in.

- After the engine case section has cooled, check that the bearings are firmly seated.

**i** **Info**

If the bearings are not firmly seated after cooling, it is likely that they will rotate in the engine case when warm. In this case, the engine case must be renewed.

- Mount oil nozzles **3**.

Guideline

Oil nozzle	M5	2 Nm (1.5 lbf ft)	Loctite® 243™
------------	----	----------------------	---------------

- Mount oil nozzle **6**.

Guideline

Oil nozzle for clutch lubrication	M6x0.75	4 Nm (3 lbf ft)
-----------------------------------	---------	-----------------

- Mount and tighten screw **2**.

Guideline

Plug, clutch lubrication	M10x1	10 Nm (7.4 lbf ft)
--------------------------	-------	--------------------

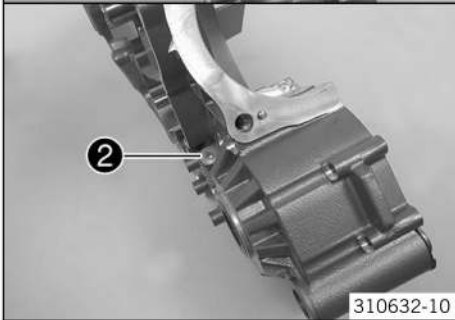
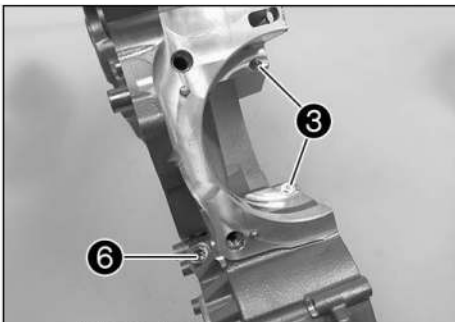

310632-10

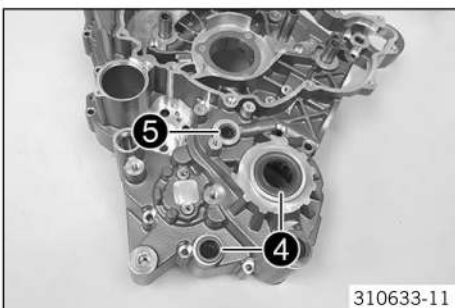

310633-11

- Press in shaft seal rings **4** until they are flush.
- Press in the shaft seal ring of push rod **5**.

Press drift (61229013000) (p. 349)
------------------------------------

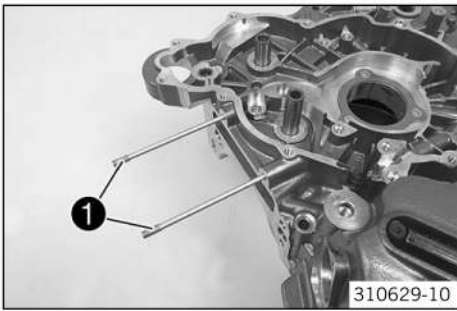

- Mount studs **1**.

Guideline

Stud, chain shaft	M6	8 Nm (5.9 lbf ft)
-------------------	----	-------------------

- Blow compressed air through all oil channels and check that they are clear.

## 18.8.6 Removing the left main bearing

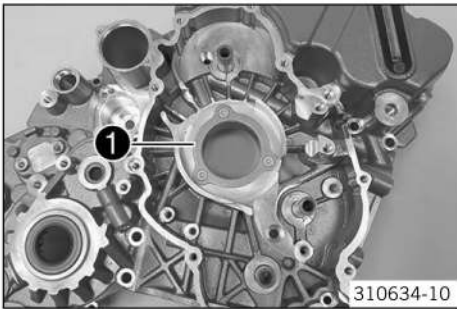

- Remove the screws and take off bearing shell bracket **1**.

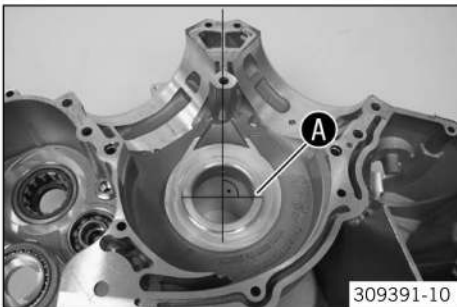

- Mark joint **A** of the main bearing shells as shown in the figure.

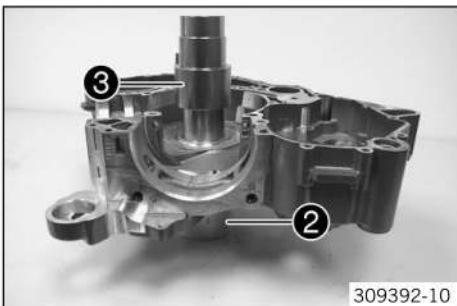

- Place the engine case section on special tool **2**.

Press sleeve (61229045000) (p. 351)

- Place special tool **3** with the smaller diameter on the bearing shells and press from the inside to the outside.

Press drift/press sleeve (61229044000) (p. 351)

## 18.8.7 Installing the left main bearing

### Preparatory work

- Select the main bearing shells. (p. 190)

### Main work

- Center the new main bearing shells **1** using special tool **2**.

Press drift/press sleeve (61229044000) (p. 351)

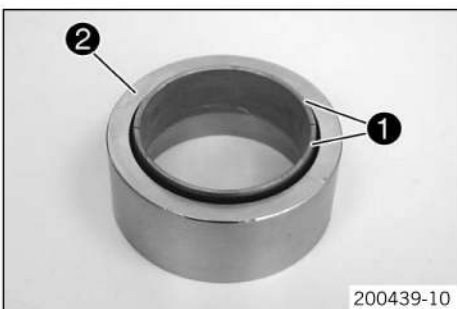

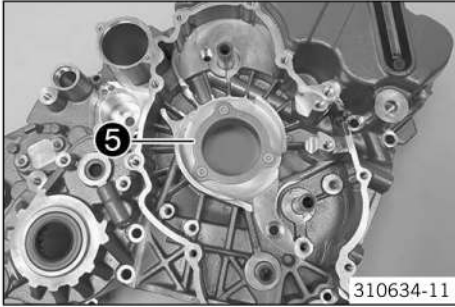
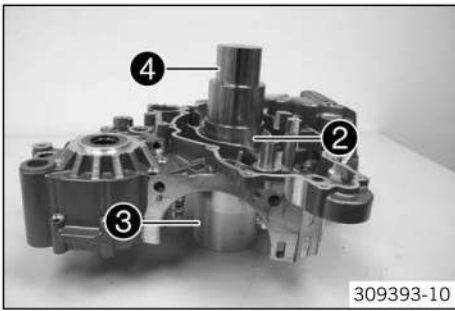

- Place the inside of the engine case section on special tool **3**.

Press sleeve (61229045000) (p. 351)

- Align the face of the new bearing shell with the marking made when it was disassembled.
- Press the bearing shells with the stepped side of special tool **4** through press sleeve **2** from the outside to the inside, all the way to the stop.

Press drift/press sleeve (61229044000) (p. 351)

- Position bearing shell bracket **5**. Mount and tighten the screws.

Guideline

Screw, bearing retainer	M5	6 Nm (4.4 lbf ft)	Loctite® 243™
-------------------------	----	----------------------	---------------

## 18.8.8 Changing the conrod bearing



### Info

Perform the operation on both connecting rods.

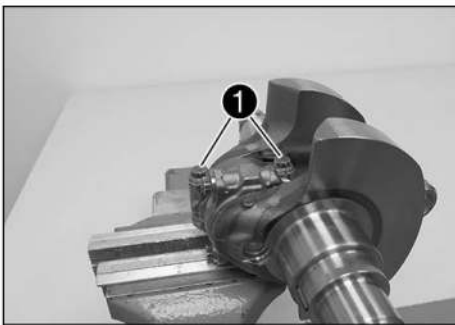

- Clamp each connecting rod separately using soft jaws.
- Remove screws **1**.

Multi-tooth wrench socket 10 mm; 1/2" drive (60029075000) (p. 347)

- Take off the bearing cap and connecting rod. Remove the bearing shells.



### Info

Mark the connecting rod bearing cap and connecting rod to ensure that each connecting rod bearing cap will be mounted on the same connecting rod.



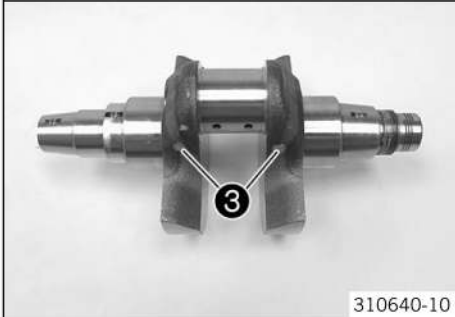
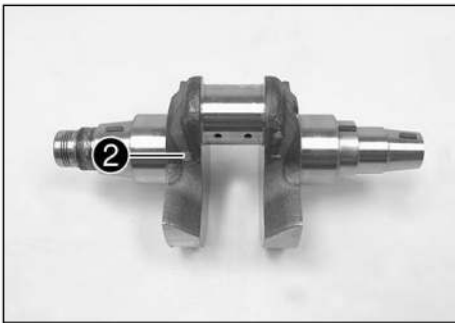

310640-10



310637-10

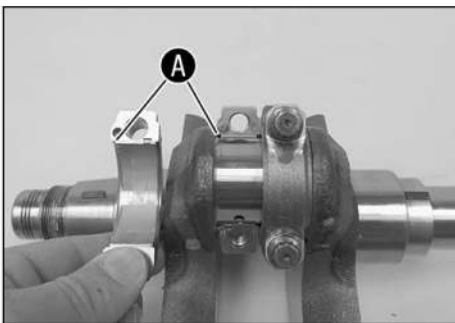

310638-10

### New crankshaft

- Select the new bearing shells according to color marking ②.



#### Info

Color marking ③ refers to the crankshaft bearing.

### Used crankshaft

- Measure the crank pin diameter and select the new bearing shells accordingly.

#### Guideline

Crankshaft - crank pin diameter	
Yellow	41.978... 41.989 mm (1.65267... 1.65311 in)
Blue	41.990... 42.000 mm (1.65315... 1.65354 in)
Red	42.001... 42.011 mm (1.65358... 1.65397 in)

- Check the radial clearance of the bottom connecting rod bearing. (📖 p. 197)
- Oil the bearing shells.
- Position the connecting rod bearing cap according to the markings made when they were disassembled. Mount the new connecting rod screws and tighten them using the special tool.

#### Guideline

Screw, conrod bearing	M10x1	Step 1 25 Nm (18.4 lbf ft) Step 2 30 Nm (22.1 lbf ft) Step 3 90°
-----------------------	-------	---

Multi-tooth wrench socket 10 mm; ½" drive (60029075000) (📖 p. 347)

Graduated disc (60029010000) (📖 p. 346)



#### Info

The conrod bearing shells are positioned laterally offset in the connecting rod to make space for radius A of the crank shaft. If mounted in reverse, the bearing shells push on the radius and the connecting rods block.

## 18.8.9 Work on the clutch cover

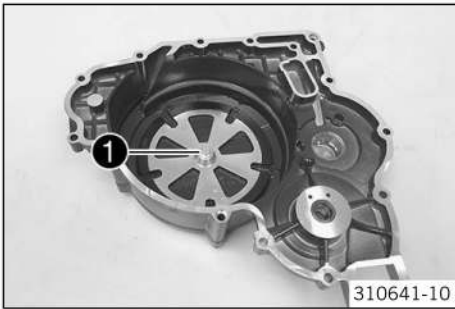

- Remove screw **1** with the bushing.
- Remove the damping plate.

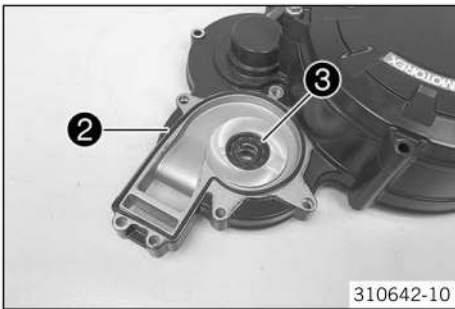

- Remove water pump cover seal **2**.
- Remove the outer shaft seal ring **3**.

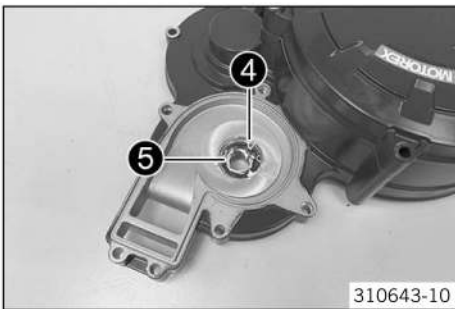

- Remove lock ring **4**.
- Remove the inner shaft seal ring **5**.

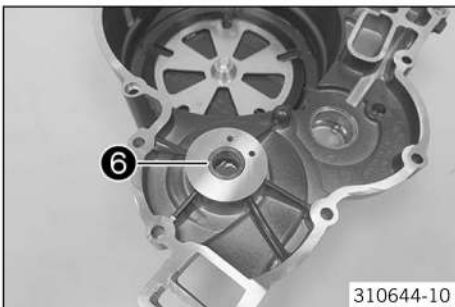

- Remove bearing bush **6**.

Bearing puller (15112017000) (📖 p. 343)
---

Internal bearing puller (15112018100) (📖 p. 343)
--

- Press in the new bearing bush until it is flush using a suitable press drift.
- Change the support bearing of the crankshaft. (📖 p. 197)

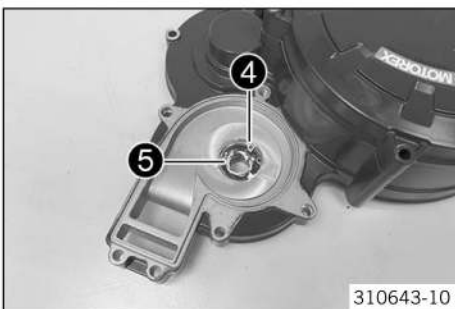

- Press in the inner shaft seal ring **5** with the closed side to the bearing bush as far as it will go.
- Mount lock ring **4**.

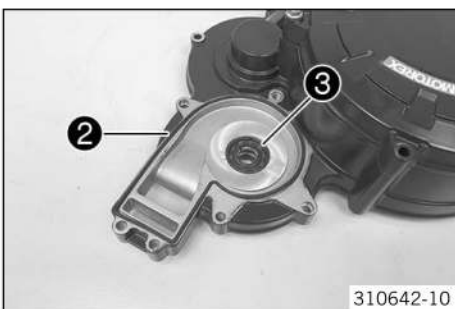

- Press in the outer shaft seal ring **3**, with the open side flush and facing outwards.
- Insert water pump cover seal **2**.

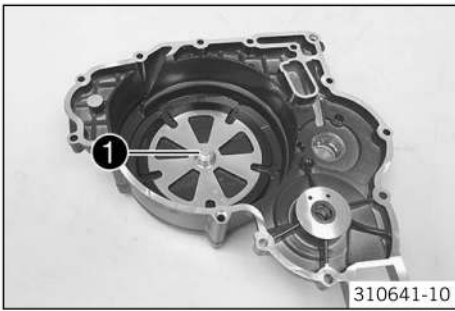

- Position the damping plate.
- Mount and tighten screw **1** with the bushing.

Guideline

Screw, damping plate	<b>EJOT ALtracs®</b> M6x14	10 Nm (7.4 lbf ft)	<b>Loctite® 243™</b>
----------------------	-------------------------------	-----------------------	----------------------

## 18.8.10 Changing the support bearing of the crankshaft

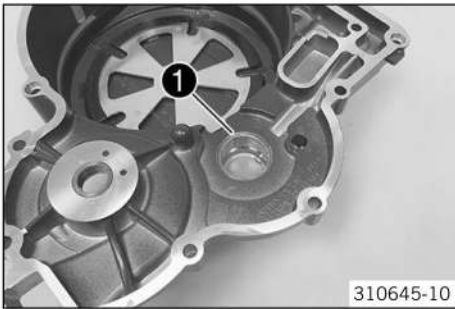

- Mark the position of bearing joint **1**.

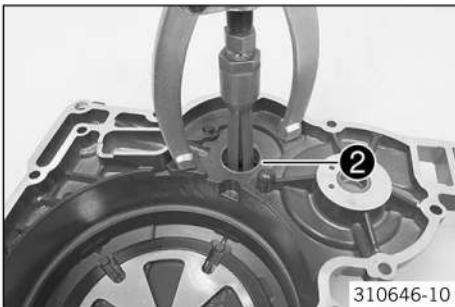

- Pull out support bearing shells **2** with the special tool.

Bearing puller (15112017000) (📖 p. 343)

Internal bearing puller (60029018000) (📖 p. 346)

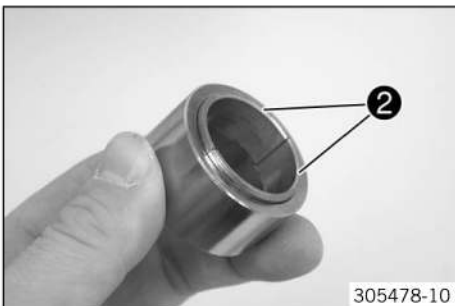

- Center the new support bearing shells **2** with the special tool.

Step bearing tool (60029046128) (📖 p. 347)



- Support the clutch cover directly under the support bearing. Press in the support bearing shells using the special tool until they are flush.

Step bearing tool (60029046128) (📖 p. 347)

## 18.8.11 Checking the radial clearance of the bottom connecting rod bearing



### Info

Perform the operation on both connecting rods.

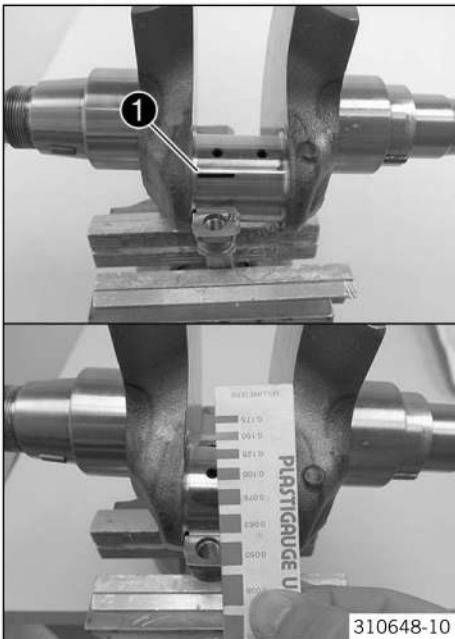

- Position the bearing shells. Insert the **Plastigauge** measuring strips **1** offset by 90° from the bearing joint.

**Plastigauge** clearance gauge (60029012000) (📄 p. 346)

- Position the connecting rod bearing cap. Mount and tighten the screws.

Guideline

Screw, conrod bearing	M10x1	Step 1 25 Nm (18.4 lbf ft) Step 2 30 Nm (22.1 lbf ft) Step 3 90°
-----------------------	-------	---

**i** **Info**

Do not twist the connecting rod.

- Remove the connecting rod bearing cap again. Compare the **Plastigauge** measuring strip with the specifications on the packaging.

Guideline

Connecting rod - radial clearance of lower conrod bearing	
New condition	0.030... 0.060 mm (0.00118... 0.00236 in)
Wear limit	0.080 mm (0.00315 in)

**i** **Info**

The width of the **Plastigauge** measuring strips indicates the bearing play.

- Clean the parts.

## 18.8.12 Checking/measuring the cylinder

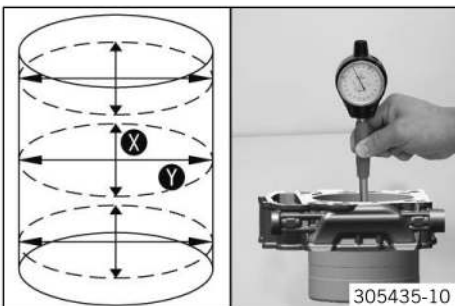

- Check the cylinder bearing surface for damage.
  - » If the cylinder bearing surface is damaged:
    - Change the cylinder and piston.
- Measure the cylinder diameter at several places on the contact surface in the **X** and **Y** axes using a micrometer to check for oval wear.

Guideline

Cylinder - bore diameter	
Size I	108.000... 108.012 mm (4.25196... 4.25243 in)
Size II	108.012... 108.025 mm (4.25243... 4.25294 in)



- The cylinder size **1** is marked on the cylinder base.



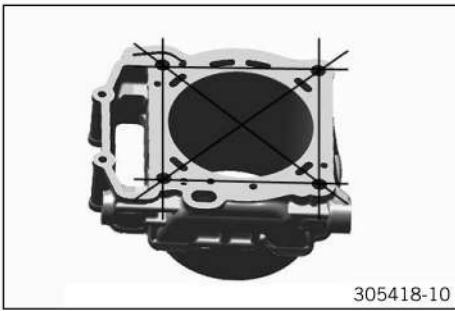

- Check the sealing area of the cylinder head for distortion using a straight edge and the special tool.

Feeler gauge (59029041100) (📖 p. 346)

Cylinder/cylinder head - sealing area distortion	≤ 0.05 mm (≤ 0.002 in)
--	------------------------

- » If the measured value does not equal the specified value:
  - Change the cylinder.

### 18.8.13 Checking/measuring the piston



- Check the piston bearing surface for damage.
  - » If the piston bearing surface is damaged:
    - Change the piston and, if necessary, the cylinder.
- Check that the piston rings can move easily in the piston ring grooves.
  - » If the piston ring is stiff:
    - Clean the piston ring groove.

**i Tip**  
Use an old piston ring to clean the piston ring groove.

- Check the piston rings for damage.
  - » If the piston ring is damaged:
    - Change the piston ring.

**i Info**  
Mount the piston ring with the marking facing upward.

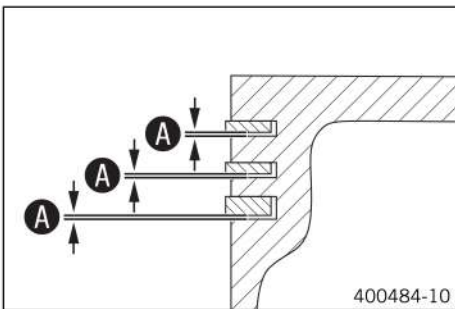

- Use the special tool to measure clearance **A** of the piston rings in the piston ring groove.

Guideline

Piston ring - groove clearance	
First ring (rectangular ring)	≤ 0.08 mm (≤ 0.0031 in)
Second ring (lower compression ring)	≤ 0.08 mm (≤ 0.0031 in)
Oil scraper ring	≤ 0.06 mm (≤ 0.0024 in)

Feeler gauge (59029041100) (📖 p. 346)

- » If clearance **A** is larger than the specified value:
  - Change the piston and piston rings.
  - Check/measure the cylinder. (📖 p. 198)
- Check the piston pin for discoloration or signs of wear.
  - » If the piston pin has strong discoloration/signs of wear:
    - Change the piston pin.
- Insert the piston pin into the connecting rod and check the bearing for play.
  - » If the piston pin bearing has too much play:
    - Change the connecting rod and the piston pin.
- Measure the piston at the piston skirt, at right angles to the piston pin, at a distance **B**.

Guideline

Piston - diameter	
Size I	107.960... 107.990 mm (4.25039... 4.25157 in)
Size II	107.970... 108.000 mm (4.25078... 4.25196 in)
Distance <b>B</b>	6 mm (0.24 in)



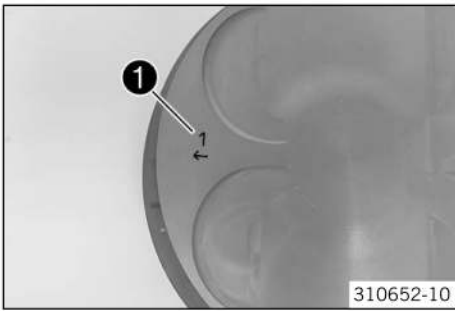

- Piston size ① is marked on the piston head.

## 18.8.14 Checking the piston ring end gap

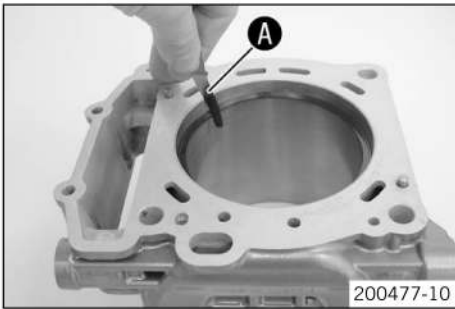

- Remove the piston ring from the piston.
- Place the piston ring in the cylinder and align it with the piston.

Guideline

Under the upper edge of the cylinder	10 mm (0.39 in)
--------------------------------------	-----------------

- Measure the end gap with special tool ①.

Guideline

Piston ring end gap	
First ring (rectangular ring)	≤ 0.50 mm (≤ 0.0197 in)
Second ring (lower compression ring)	≤ 0.60 mm (≤ 0.0236 in)
Oil scraper ring	≤ 0.60 mm (≤ 0.0236 in)

Feeler gauge (59029041100) (📖 p. 346)

- » If the end gap is greater than the specified value:
  - Check/measure the cylinder. (📖 p. 198)
- » If the cylinder wear is within the tolerance range:
  - Change the piston ring.
- Mount the piston ring with the marking facing toward the piston head.

## 18.8.15 Checking the piston/cylinder mounting clearance



- Check/measure the cylinder. (📖 p. 198)
- Check/measure the piston. (📖 p. 199)
- The smallest piston/cylinder mounting clearance is the result of the smallest cylinder bore diameter minus the largest piston diameter. The largest piston/cylinder mounting clearance is the result of the largest cylinder bore diameter minus the smallest piston diameter.

Guideline

Piston/cylinder - mounting clearance	
Size I	0.010... 0.042 mm (0.00039... 0.00165 in)
Size II	0.012... 0.052 mm (0.00047... 0.00205 in)
Wear limit	0.10 mm (0.0039 in)

## 18.8.16 Work on the cylinder head



### Info

The following operations apply to both cylinder heads.

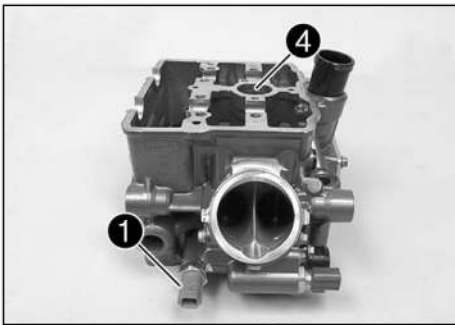

- Remove oil pressure switch **1**.



**Info**

This only applies to the front cylinder head!

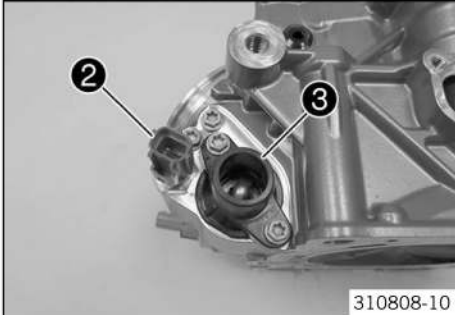

310808-10

- Remove engine coolant temperature sensor **2**.
- Remove screws.
- Remove thermostat case **3** and the thermostat.
- Remove O-rings **4**.

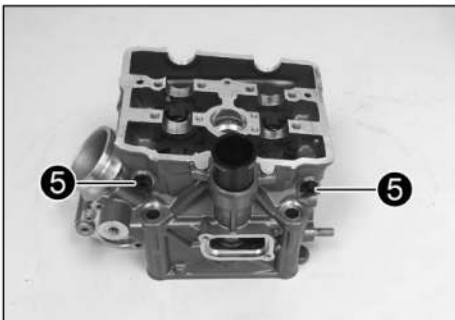

- Remove plugs **5** with the O-ring.



310809-10

- Pull out cam lever shafts **6** with a suitable M5 screw and remove the cam lever.

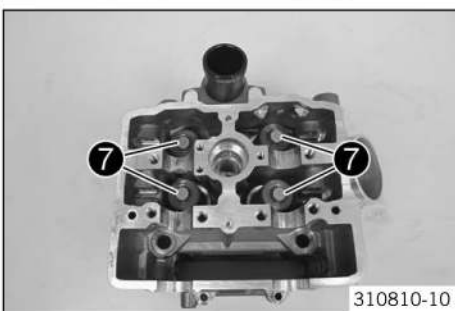

310810-10

- Remove shims **7** and label the normal built-in position.

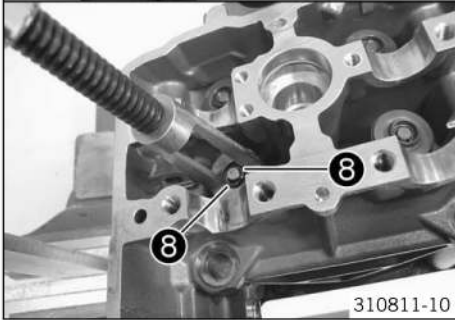
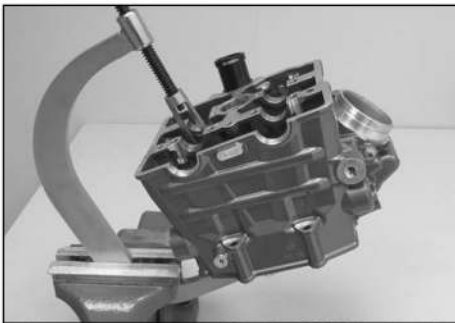

310811-10

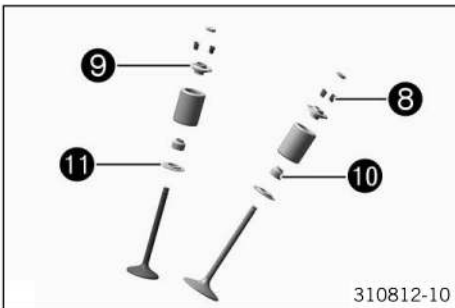

310812-10

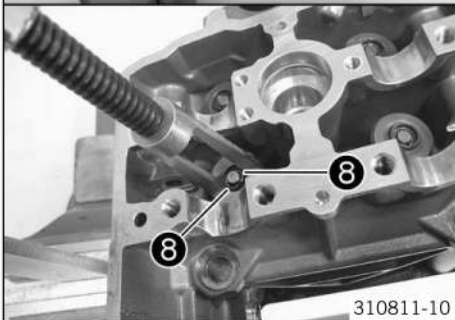
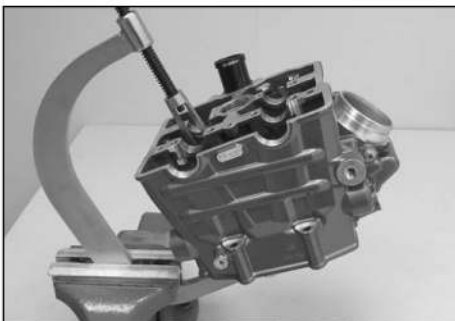

310811-10

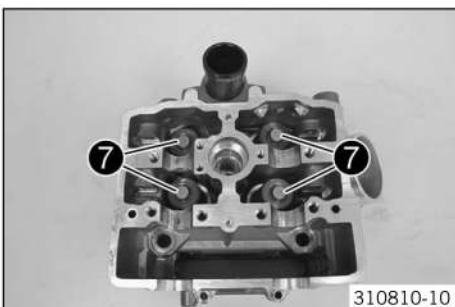

310810-10

- Tension the valve spring with a special tool.

Valve spring mounter (59029019000) (📖 p. 345)
---

Insert for valve spring lever (78029060000) (📖 p. 354)
--

- Remove valve keys **8** and release tension on the valve spring.

- Remove valve spring retainer **9**, valve spring, valve stem seals **10** and valve spring seats **11**.

**i** **Info**

Place the valves in a carton corresponding to their installation position and label them.

- Check the cylinder head. (📖 p. 203)
- Mount valve spring seats **11** and new valve stem seals **10**.
- Mount valve spring and valve spring retainer **9**.
- ✓ The tight winding of the valve spring is at the bottom.
- Tension the valve spring with a special tool.

Valve spring mounter (59029019000) (📖 p. 345)
---

Insert for valve spring lever (78029060000) (📖 p. 354)
--

- Mount valve keys **8**. Release the tension on the valve spring.

**i** **Info**

When mounting the valve keys, check that they are seated correctly; preferably, fix the valve keys to the valve with a little grease.

- Place shims **7** into the valve spring retainer according to their normal built-in position.

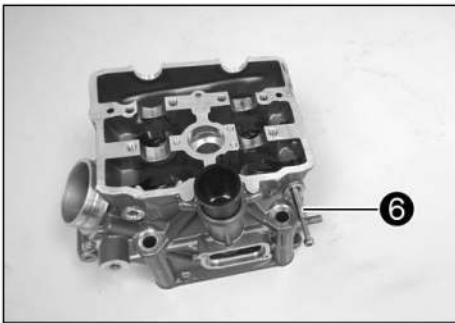

- Position the cam lever and mount cam lever shafts **6**.
- Mount plugs **5** with new O-rings.

Guideline

Plug, cam lever axis	M10x1	15 Nm (11.1 lbf ft)
----------------------	-------	------------------------



310813-10

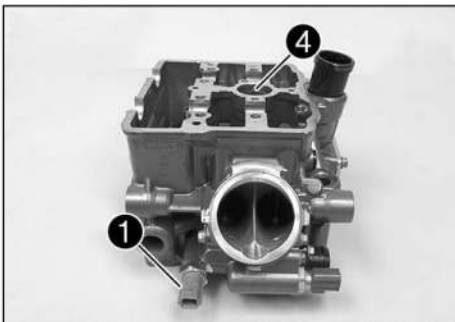

- Mount oil pressure sensor **1**.

Guideline

Oil pressure sensor	M10x1	10 Nm (7.4 lbf ft)
---------------------	-------	--------------------

**i Info**  
This only applies to the front cylinder head!

- Mount engine coolant temperature sensor **2**.

Guideline

Coolant temperature sensor	M12x1.5	12 Nm (8.9 lbf ft)
----------------------------	---------	--------------------

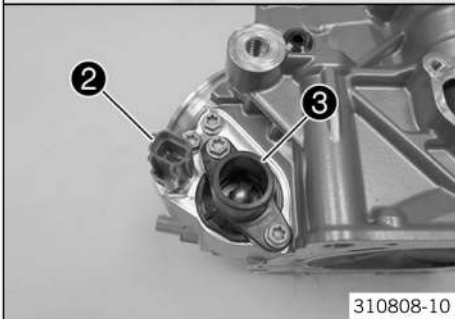

310808-10

- Mount the thermostat and thermostat case **3**.
- Mount and tighten screw.

Guideline

Screw, thermostat case	M6	10 Nm (7.4 lbf ft)	Loctite® 243™
------------------------	----	-----------------------	---------------

- Mount and grease O-rings **4**.

### 18.8.17 Checking the cylinder head



305433-10

- Check the sealing area of the spark plug thread and the valve seats for damage and tearing.
  - » If there is wear or tearing:
    - Change the cylinder head.
- Check the valve guides using the special tool.

Limit plug gauge (59029026006) (🗨 p. 346)

Valve guide - diameter		
New condition	6.004... 6.016 mm (0.23638... 0.23685 in)	
Wear limit	6.150 mm (0.24213 in)	

- » If the special tool is easy to insert into the valve guide:
  - Change the valve guide and valve.

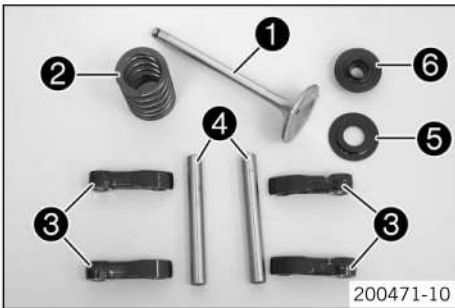
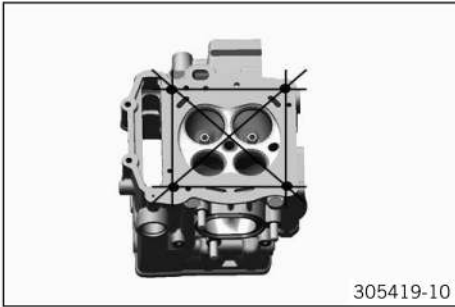
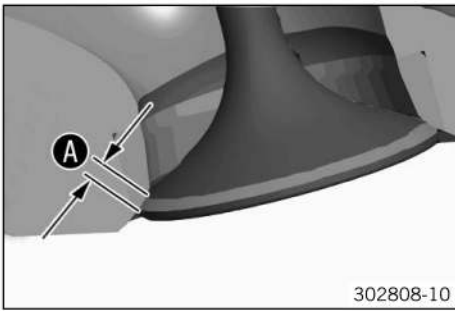

- Check sealing seat **A** of the valves.

Valve - sealing seat width	
Intake: New condition	0.90 mm (0.0354 in)
Intake: Wear limit	1.5 mm (0.059 in)
Exhaust: New condition	1.0 mm (0.039 in)
Exhaust: Wear limit	2.0 mm (0.079 in)

- » If the measured value does not equal the specified value:
  - Machine the valve seat.

- Check the sealing area of the cylinder for distortion using a straight edge and the special tool.

Feeler gauge (59029041100) (📄 p. 346)	
---------------------------------------	--

Cylinder/cylinder head - sealing area distortion	≤ 0.05 mm (≤ 0.002 in)
--	------------------------

- » If the measured value does not equal the specified value:
  - Change the cylinder head.

- Check the pivot points of the camshafts in the cylinder head and in the camshaft bearing bridge for damage and wear.

- » If there is damage or wear:
  - Change the cylinder head with the camshaft bearing bridge.

- Check valve **1** for damage and wear.

- » If there is damage or wear:
  - Change the valve.

- Check the valve for run-out.

Valve - run-out	
Intake: on the valve plate	≤ 0.03 mm (≤ 0.0012 in)
Exhaust: on the valve plate	≤ 0.03 mm (≤ 0.0012 in)

- » If the measured value does not equal the specified value:
  - Change the valve.

- Check the valve stem diameter.

Valve – valve stem diameter	
Exhaust	5.956... 5.970 mm (0.23449... 0.23504 in)
Intake	5.966... 5.980 mm (0.23488... 0.23543 in)

- » If the measured value does not equal the specified value:
  - Change the valve.

- Check valve spring **2** for damage and wear.

- » If there is damage or wear:
  - Change the valve spring.

- Measure the valve spring lengths.

Valve spring - length	
New condition	42.70 mm (1.6811 in)
Wear limit	41.8 mm (1.646 in)

- » If the measured value does not equal the specified value:
  - Change the valve springs.

- Check cam lever **3** for damage and wear.

- » If there is damage or wear:
  - Change the cam lever.

- Check cam lever shaft **4** for damage and wear.

- » If there is damage or wear:

- Change the cam lever shaft.
- Check valve spring support **5** for damage and wear.
  - » If there is damage or wear:
    - Change the valve spring seat.
- Check valve spring retainer **6** for damage and wear.
  - » If there is damage or wear:
    - Change the valve spring retainer.

## 18.8.18 Work on the right idler

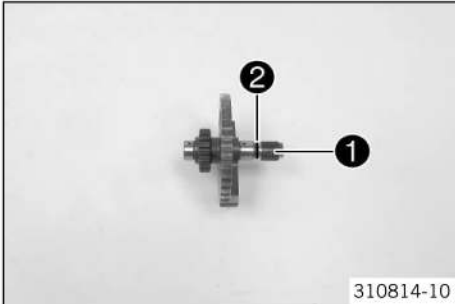

- Remove bushing **1**.
- Remove O-ring **2**.
- Mount the new O-ring **2**.
- Mount the new bushing **1**.

## 18.8.19 Checking the timing assembly

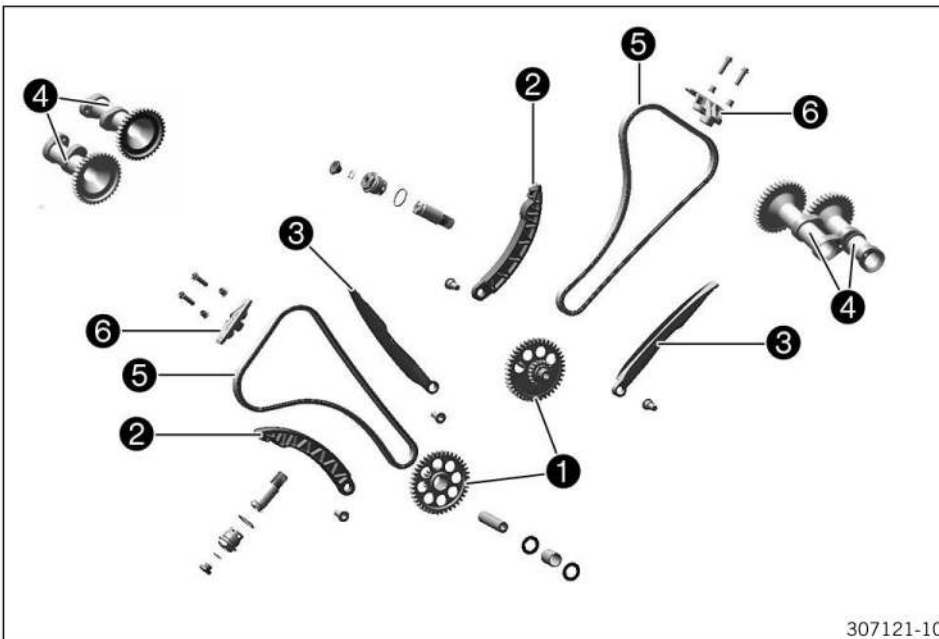

- Clean all parts well.
- Check idler **1** for damage and wear.
  - » If there is damage or wear:
    - Change the idler.
- Check timing chain tensioning rail **2** for damage and wear.
  - » If there is damage or wear:
    - Change the timing chain tensioning rail.
- Check timing chain guide rail **3** for damage and wear.
  - » If there is damage or wear:
    - Change the timing chain guide rail.
- Check camshaft **4** for damage and wear.
  - » If there is damage or wear:
    - Change the camshaft.
    - If the cam surface is damaged, check the oil supply to the camshaft and cam lever.

- Check timing chain **5** for damage and wear.
  - » If there is damage or wear:
    - Change the timing chain.
- Check that the timing chain links move easily. Let the timing chain hang down freely.
  - » If the chain links no longer straighten out:
    - Change the timing chain.
- Check guide rail **6** for damage and wear.
  - » If there is damage or wear:
    - Change the guide rail.

## 18.8.20 Preparing the timing chain tensioner for installation



- Fully compress the timing chain tensioner.



### Info

This requires considerable force since the oil has to be pressed out.

- Release the timing chain tensioner.
  - ✓ Without pressure, the timing chain tensioner expands fully.



- Place two compensating disks or similar aids next to the timing chain tensioner piston. This should ensure that when pushed down, the piston does not fully withdraw.  
Guideline

Thickness of the compensating disks	2... 2.5 mm (0.08... 0.098 in)
-------------------------------------	--------------------------------

- Release the timing chain tensioner.
  - ✓ The latching system locks and the piston stops moving.

End position of piston after latching	3 mm (0.12 in)
---------------------------------------	----------------



### Info

This position is necessary for installation.

If the timing chain tensioner is now pressed in once more (while it is installed) and then pulled out no more than halfway (preventing it from coming out fully), the latching system locks and the timing chain tensioner can no longer be compacted; this function is necessary to ensure sufficient tension of the timing chain, even at low oil pressure.

## 18.8.21 Pretensioning the spread transmission

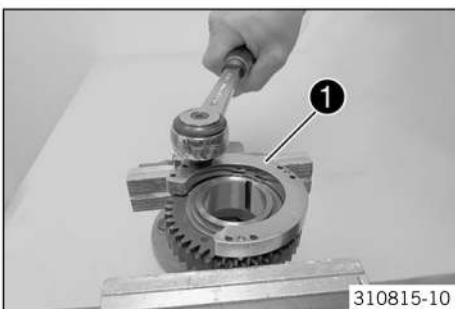

- Secure the primary gear in the vise.



### Info

Use soft jaws.

- Mount special tool **1**.

Spread transmission fixture (61329035000) (📄 p. 352)
--



- Clamp the spread transmission until the holes align.
- Mount special tool **2** until it stops.

Spread transmission locking pin (61329033000) (📄 p. 352)
--



## 18.8.22 Checking the oil pressure regulator valve

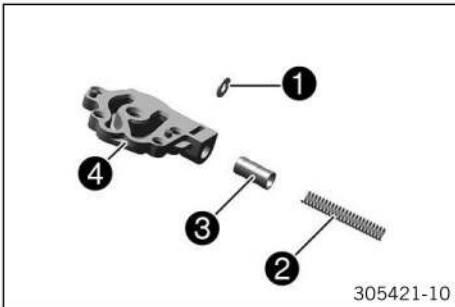

- Remove supporting plate **1** and spring **2**.
- Measure the length of spring **2**.

Oil pressure regulator valve - minimum spring length	39 mm (1.54 in)
--	-----------------

- » If the measured length is less than the specified value:
  - Change the spring.
- Check control piston **3** for damage and wear.
  - » If there is damage or wear:
    - Change the control piston.
- Check the control piston hole in oil pump cover **4** for damage and wear.
  - » If there is damage or wear:
    - Change the oil pump cover.
- Oil control piston **3** and spring **2** well and mount them.
- Mount supporting plate **1**.

## 18.8.23 Checking the lubrication system



### Info

The following operations apply to all three oil pumps.

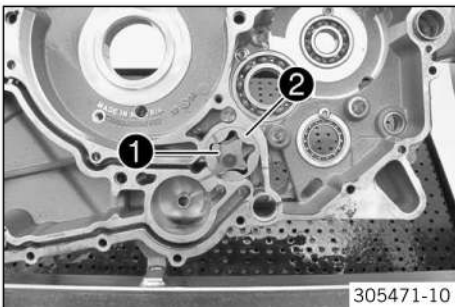

- Check the clearance between internal rotor **1** and external rotor **2** and between the external rotor and the engine case.

Oil pumps	
Clearance between external rotor and engine case	0.20... 0.40 mm (0.0079... 0.0157 in)
Clearance between external rotor and internal rotor	0.10... 0.25 mm (0.0039... 0.0098 in)
Axial clearance	0.04... 0.25 mm (0.0016... 0.0098 in)

- » If the clearance exceeds the specifications:
  - Change the oil pump and, if necessary, the engine case.

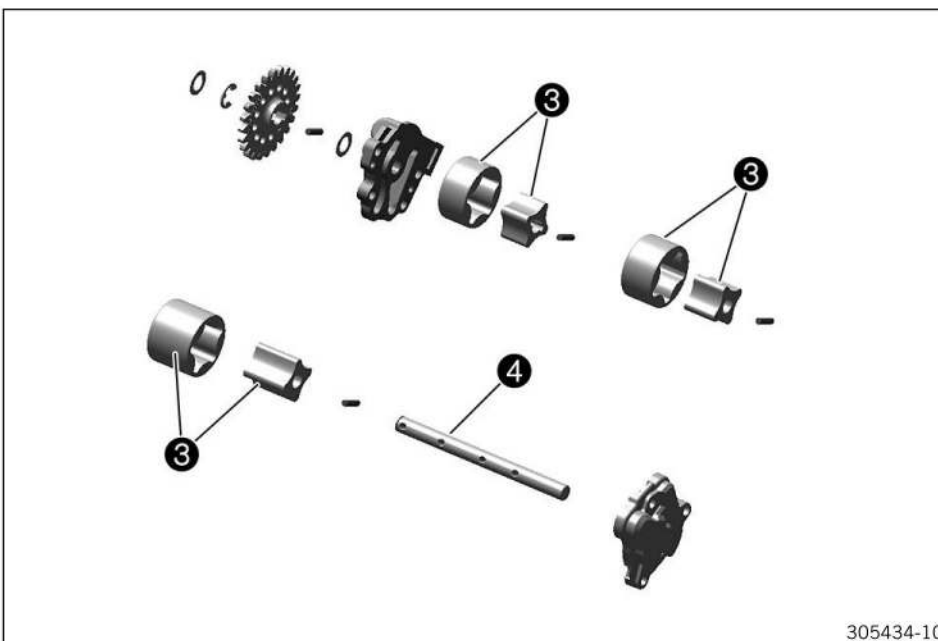

- Check the internal rotor and external rotor of oil pumps **3** for damage and wear.
  - » If there is damage or wear:

- Change the oil pumps.
- Check oil pump shaft **4** for damage and wear.
  - » If there is damage or wear:
    - Change the oil pump shaft.
- Check the oil pump cover for damage and wear.
  - » If there is damage or wear:
    - Change the oil pump cover.

## 18.8.24 Checking the clutch

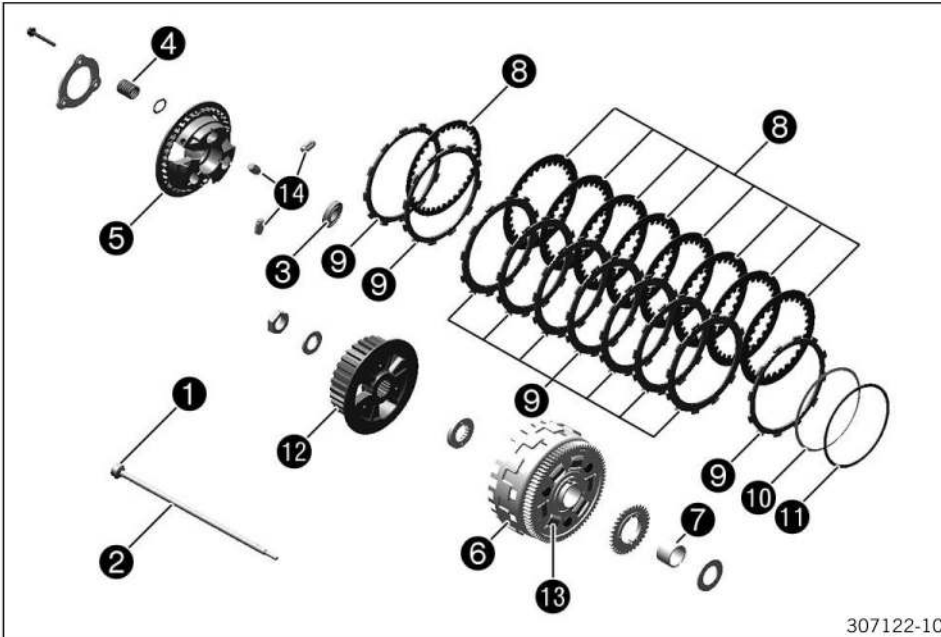

- Check pressure piece **1** for damage and wear.
  - » If there is damage or wear:
    - Change the push rod.
- Place push rod **2** on a level surface and check it for run-out.
  - » If there is run-out:
    - Change the push rod.
- Check axial bearing **3** for damage and wear.
  - » If there is damage or wear:
    - Change the axial bearing.
- Check the length of clutch springs **4**.

Clutch spring - length	≥ 43.0 mm (≥ 1.693 in)
------------------------	------------------------

- » If the clutch spring length is less than the specified value:
  - Change all clutch springs.
- Check the contact surface of clutch pressure cap **5** for damage and wear.
  - » If there is damage or wear:
    - Change the clutch pressure cap.
- Check the thrust surfaces of the clutch facing discs in clutch basket **6** for wear.

Clutch basket - thrust surface of clutch facing discs	
Wear limit	0.5 mm (0.02 in)

- » If the thrust surface is very worn:
  - Change the clutch pack and clutch basket.
- Check needle bearing **7** for damage and wear.
  - » If there is damage or wear:
    - Change the needle bearing.

- Check the intermediate clutch discs **8** for damage and wear.
  - » If the intermediate clutch discs are not level and have pittings:
    - Change the clutch pack.
- Check clutch facing discs **9** for discoloration and scoring.
  - » If there is discoloration or scoring:
    - Change the clutch pack.
- Check the thickness of the clutch pack.

Clutch pack - thickness	
New condition	48.00... 47.2 mm (1.8898... 1.858 in)
Wear limit	46.00 mm (1.811 in)

- » If the clutch pack does not meet specifications:
  - Change the clutch pack.
- Check pretension ring **10** and support ring **11** for damage and wear.
  - » If there is damage or wear:
    - Change the pretension ring and support ring.
- Check inner clutch hub **12** for damage and wear.
  - » If there is damage or wear:
    - Change the inner clutch hub.
- Check springs **13** of the clutch basket for damage and wear.
  - » If there is damage, wear or play in the direction of rotation:
    - Change the clutch basket.
- Check damper **14** for damage and wear.

**i Info** If the clutch pressure cap can be mounted without resistance from the damper, the dampers are too hard and are worn out.

- » If there is damage or wear:
  - Change the damper.

## 18.8.25 Checking the shift mechanism

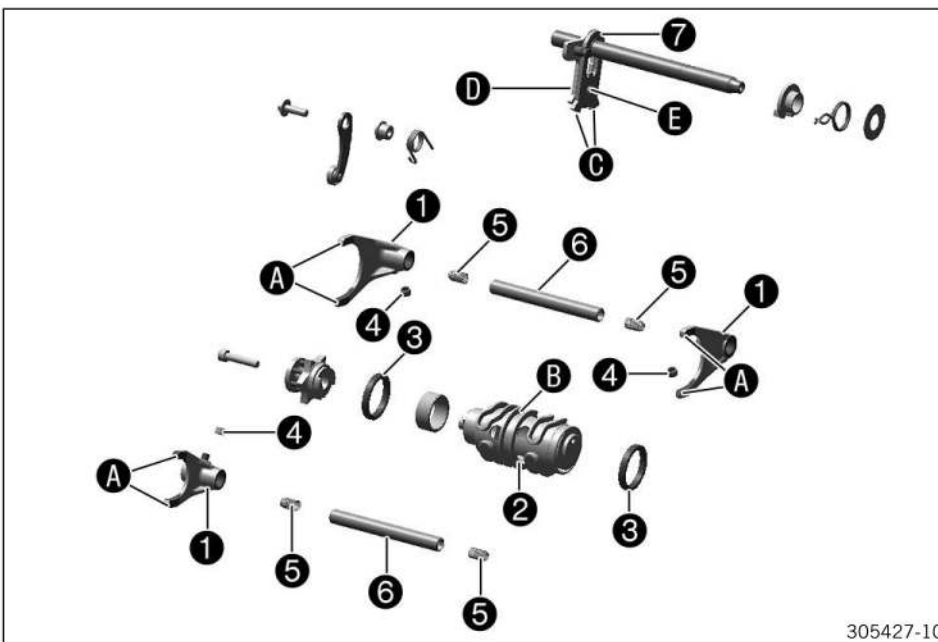

305427-10

- Check shift forks **1** at leaf **A** for wear.

Shift fork	
Thickness at leaf	4.85... 4.95 mm (0.1909... 0.1949 in)
Clearance in the sliding gear groove: New condition	0.35... 0.55 mm (0.0138... 0.0217 in)
Clearance in the sliding gear groove: Wear limit	0.70 mm (0.0276 in)

- » If the measured value does not equal the specified value:
  - Change the shift fork and gear wheel pair.
- Check shift grooves **B** of shift drum **2** for wear.
  - » If the shift groove is worn:
    - Change the shift drum.
- Check the seat of the shift drum in bearings **3**.
  - » If the shift drum is not seated correctly:
    - Change the shift drum and/or the bearing.
- Check bearing **3** for stiffness and wear.
  - » If the bearings do not move freely or are worn:
    - Change the bearings.
- Check shift drums **4** for ovality, surface damage and cracking.
  - » If the shift drum is oval, or shows signs of surface damage or cracks:
    - Change the shift drum.
- Check springs **5** of the shift rails for damage and wear.
  - » If the spring is broken or worn:
    - Change the spring of the shift rail.
- Check the shift rails **6** on a flat surface for run-out.
  - » If there is run-out:
    - Change the shift rail.
- Check shift rails for scoring, signs of corrosion and stiffness in the shift fork.
  - » If there is scoring or corrosion, or if the shift fork is stiff:
    - Change the shift rail.
- Check sliding plate **7** in contact areas **C** for wear.
  - » If the sliding plate is worn:
    - Change the sliding plate.
- Check return surface **D** on the sliding plate for wear.
  - » If deep notches are present:
    - Change the sliding plate.
- Check guide pin **E** for looseness and wear.
  - » If the guide pin is loose and/or worn:
    - Change the sliding plate.

## 18.8.26 Preassembling the shift shaft

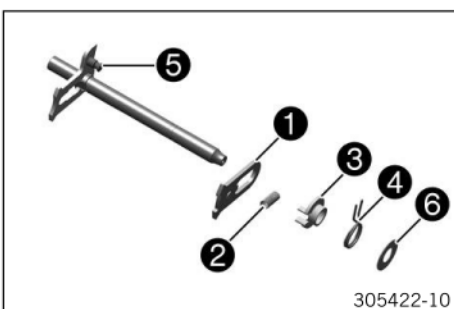

- Fix the short end of the shift shaft in a vise.

Guideline

Use soft jaws.

- Mount sliding plate **1** with the guide pin facing down and attach the guide pin to the shift quadrant.
- Mount preload spring **2**.
- Push on spring guide **3**, push return spring **4** over the spring guide with the offset end facing upward and lift the offset end over abutment bolt **5**.
- Mount stop disk **6**.

## 18.8.27 Disassembling the main shaft

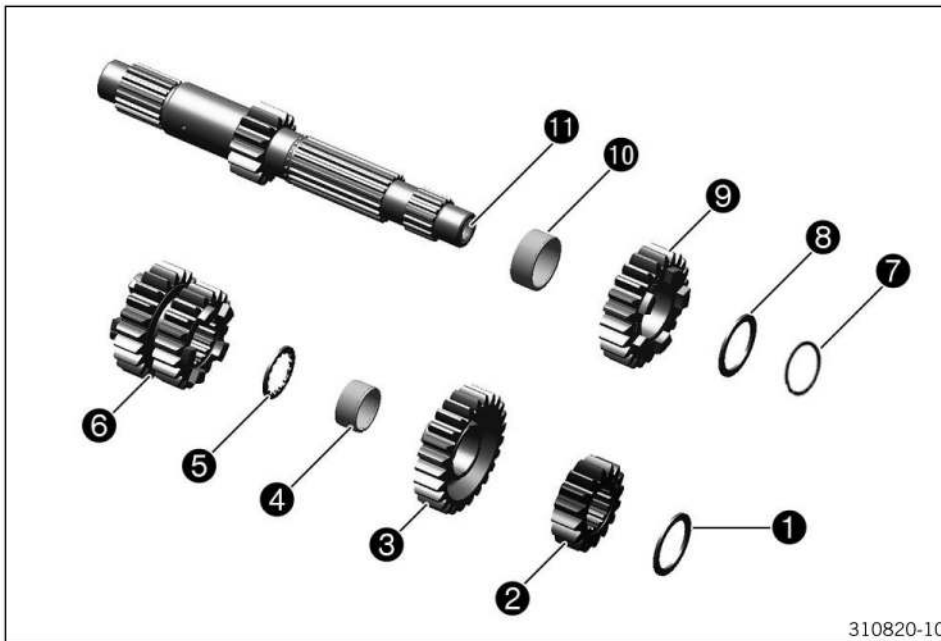

310820-10

- Secure the main shaft with the toothed end facing downward in the bench vise.

## Guideline

Use soft jaws.

- Remove stop disk **1** and second-gear fixed gear **2**.
- Remove sixth-gear idler gear **3**.
- Remove needle bearing **4** and stop disk **5**.
- Remove third/fourth-gear sliding gear **6**.
- Remove lock ring **7**.
- Remove stop disk **8** and fifth-gear idler gear **9**.
- Remove needle bearing **10**.
- Remove needle bushing **11** with a suitable tool.

**Info**

Only needs to be removed in case of wear.

## 18.8.28 Disassembling the countershaft

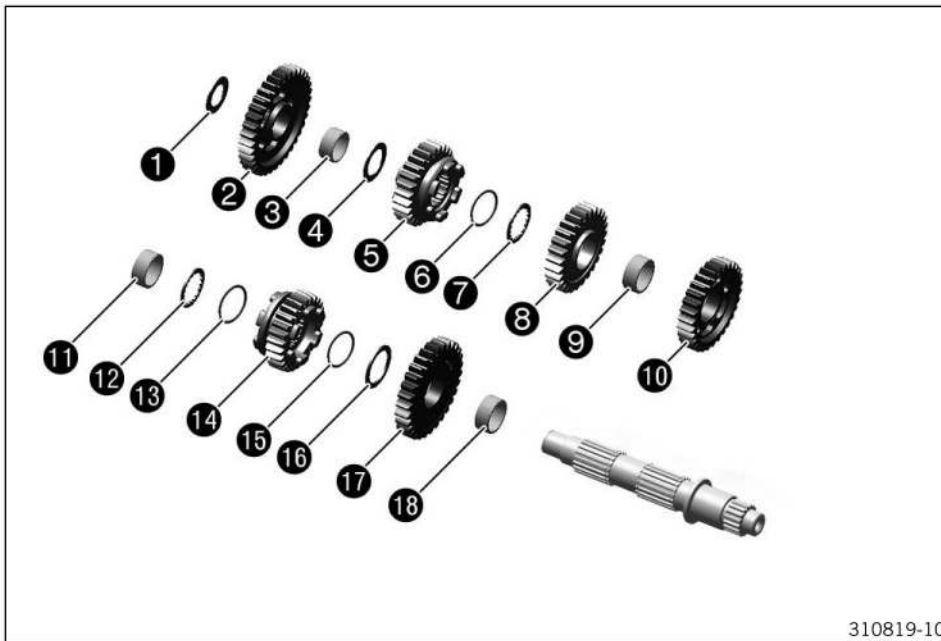

310819-10

- Secure the countershaft with the toothed end facing downward in the bench vise.

## Guideline

Use soft jaws

- Remove stop disk ① and first-gear idler gear ②.
- Remove needle bearing ③ and stop disk ④.
- Remove the fifth-gear sliding gear ⑤ and lock ring ⑥.
- Remove stop disk ⑦ and fourth-gear idler gear ⑧.
- Remove needle bearing ⑨ and third-gear idler gear ⑩.
- Remove needle bearing ⑪ and stop disk ⑫.
- Remove lock ring ⑬ and sixth-gear sliding gear ⑭.
- Remove lock ring ⑮ and stop disk ⑯.
- Remove second-gear idler gear ⑰ and needle bearing ⑱.

## 18.8.29 Checking the transmission

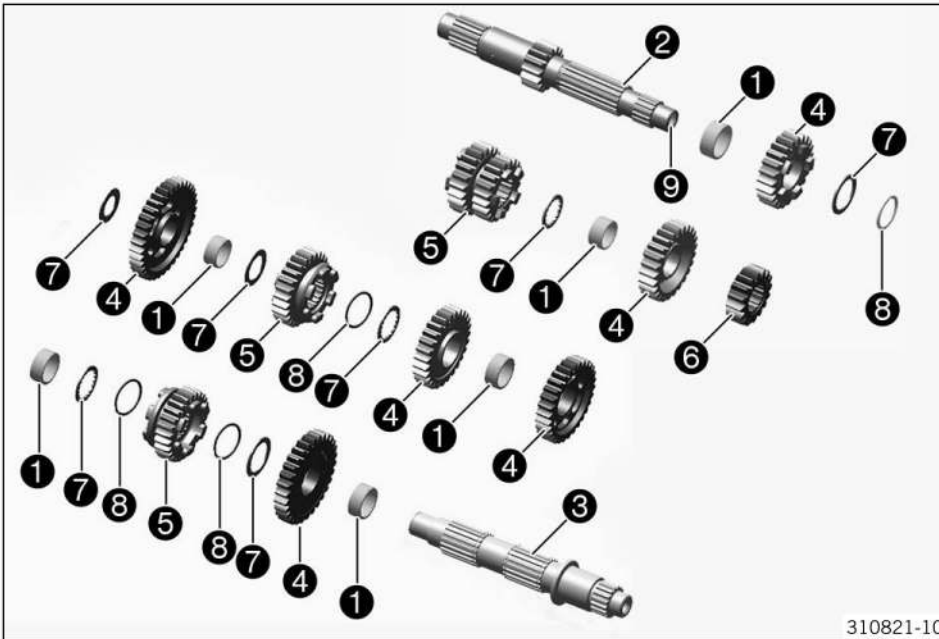

310821-10

- Check needle bearings **1** for damage and wear.
  - » If there is damage or wear:
    - Change the needle bearing.
- Check the pivot points of main shaft **2** and countershaft **3** for damage and wear.
  - » If there is damage or wear:
    - Change the main shaft and/or countershaft.
- Check the tooth profiles of main shaft **2** and countershaft **3** for damage and wear.
  - » If there is damage or wear:
    - Change the main shaft and/or countershaft.
- Check the pivot points of idler gears **4** for damage and wear.
  - » If there is damage or wear:
    - Change the gear wheel pair.
- Check the shift dogs of idler gears **4** and sliding gears **5** for damage and wear.
  - » If there is damage or wear:
    - Change the gear wheel pair.
- Check the tooth faces of idler gears **4**, sliding gears **5**, and fixed gear **6** for damage and wear.
  - » If there is damage or wear:
    - Change the gear wheel pair.
- Check the tooth profiles of sliding gears **5** for damage and wear.
  - » If there is damage or wear:
    - Change the gear wheel pair.
- Check sliding gear **5** for smooth operation in the profile of main shaft **2**.
  - » If the solid gear does not move freely:
    - Change the sliding gear or the main shaft.
- Check sliding gears **5** for smooth operation in the profile of countershaft **3**.
  - » If the solid gear does not move freely:
    - Change the sliding gear or the countershaft.
- Check stop disks **7** for damage and wear.
  - » If there is damage or wear:
    - Change the stop disks.
- Use new lock rings **8** with every repair.
- Check stop disks **9** for damage and wear.

- » If there is damage or wear:
  - Change the needle bushing.

## 18.8.30 Assembling the main shaft



### Info

Use new lock rings with every repair.

### Preparatory work

- Oil all parts carefully before assembling.
- Check the transmission. (📖 p. 213)

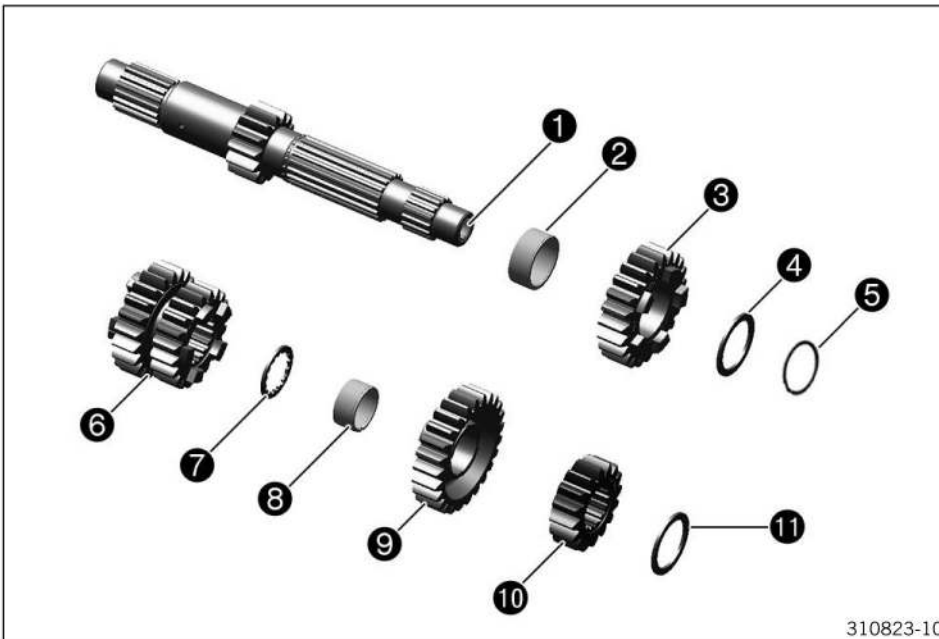

310823-10

### Main work

- Secure the main shaft with the toothed end facing downward in the bench vise.

#### Guideline

Use soft jaws

- If removed, mount the new needle bushing **1** with suitable tools.
- Mount needle bearing **2** and mount fifth-gear idler gear **3** with the shift dogs facing up.
- Mount stop disk **4** and lock ring **5**.
- Mount third/fourth-gear sliding gear **6** with the small gear wheel facing up.
- Mount stop disk **7** and needle bearing **8**.
- Attach sixth gear idler gear **9** with the shift dog facing downward.
- Attach second-gear fixed gear **10** with the collar facing downward and stop disk **11**.
- Finally, check all gear wheels for smooth operation.

## 18.8.31 Assembling the countershaft



### Info

Use new lock rings with every repair.

### Preparatory work

- Oil all parts carefully before assembling.
- Check the transmission. (📖 p. 213)



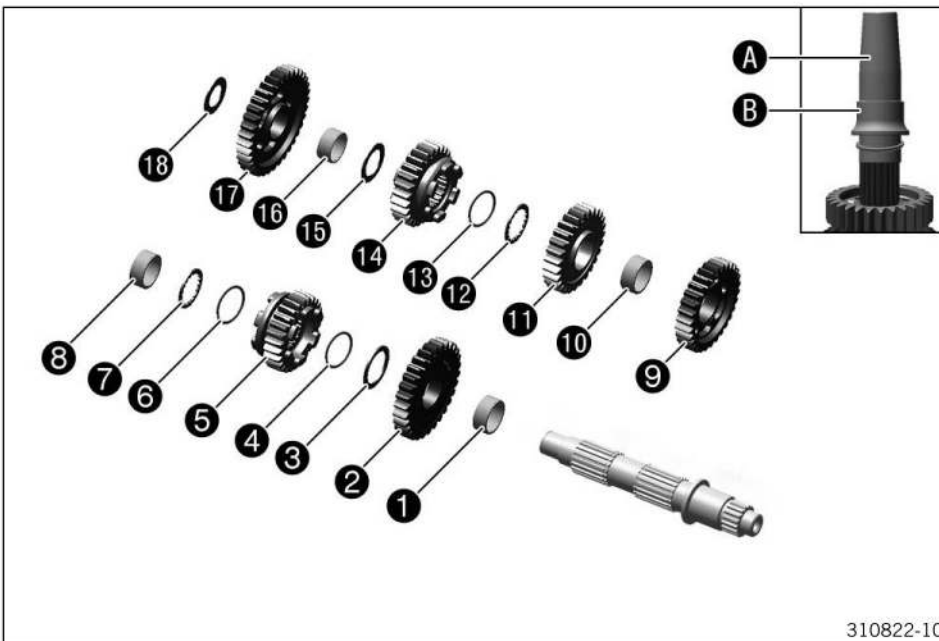

### Main work

- Secure the countershaft with the toothed end facing downward in the bench vise.

#### Guideline

Use soft jaws

- Mount needle bearing ① and second-gear idler gear ② onto the countershaft with the protruding collar facing downward.
- Mount stop disk ③.
- Position special tool A on the transmission shaft.

Mounting tool for lock ring (61229032000) (p. 350)

- Position lock ring ④ on special tool A and push down with sleeve B.
- ✓ The lock ring engages in the groove of the transmission shaft.
- Mount sixth-gear sliding gear ⑤ with the shift groove facing up.
- Position special tool A on the transmission shaft.

Mounting tool for lock ring (61229032000) (p. 350)

- Position lock ring ⑥ on special tool A and push down with sleeve B.
- ✓ The lock ring engages in the groove of the transmission shaft.
- Mount stop disk ⑦.
- Mount needle bearing ⑧ and the third-gear idler gear ⑨ with the collar facing up.
- Mount needle bearing ⑩ and the fourth-gear idler gear ⑪ with the collar facing down.
- Mount stop disk ⑫.
- Position special tool A on the transmission shaft.

Mounting tool for lock ring (61229032000) (p. 350)

- Position lock ring ⑬ on special tool A and push down with sleeve B.
- ✓ The lock ring engages in the groove of the transmission shaft.
- Mount fifth-gear sliding gear ⑭ with the shift groove facing down and mount stop disk ⑮.
- Mount needle bearing ⑯, first-gear idler gear ⑰ with the recess facing down, and stop disk ⑱.
- Finally, check all gear wheels for smooth operation.

## 18.8.32 Measuring the main shaft axial play

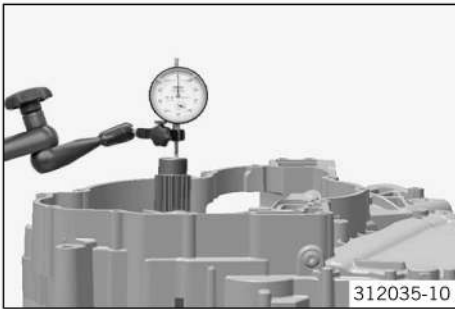

- Mount transmission in the right section of the engine case.



### Info

Do not forget the dowels.

- Mount the left section of the engine case.
- Mount and tighten the screws.

### Guideline

Screw, engine case	M8	18 Nm (13.3 lbf ft)
Screw, engine case	M6	10 Nm (7.4 lbf ft)

- Mount the dial gauge support on the engine case and measure and note down the main shaft axial play.

### Guideline

Main shaft axial clearance	0.02... 0.15 mm (0.0008... 0.0059 in)
----------------------------	--

- » If the measured value does not meet specifications:
  - Calculate the thickness of the stop disk.
  - Remove screws and take off section of the engine case.
  - Mount corresponding stop disk on the main shaft.

## 18.8.33 Checking electric starter operation

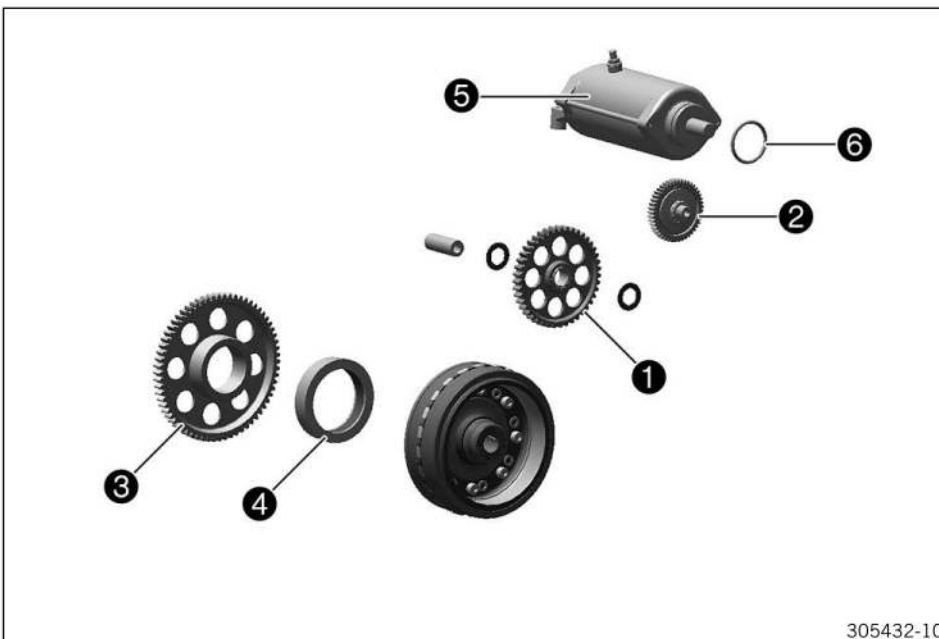

305432-10

- Check the gear mesh and bearing of starter idler gear **1** for damage and wear.
  - » If there is damage or wear:
    - Change the starter idler gear.
- Check the gear mesh and bearing of torque limiter **2** for damage and wear.
  - » If there is damage or wear:
    - Change the torque limiter.
- Check the gear mesh and bearing of freewheel gear **3** for damage and wear.
  - » If there is damage or wear:
    - Change the free-wheel-gear and/or the bearing.
- Check freewheel **4** for damage and wear.
  - » If there is damage or wear:
    - Change the freewheel.

- Checking the gear mesh of starter motor **5** for damage and wear
  - » If there is damage or wear:
    - Change the starter motor.
- Change O-ring **6** of the starter motor.
- Connect the negative cable of a 12 volt power supply to the housing of the starter motor. Connect the positive cable of the power supply briefly with connector of the starter motor.
  - » If the starter motor does not turn when the circuit is closed:
    - Change the starter motor.

### 18.8.34 Checking the free-wheel

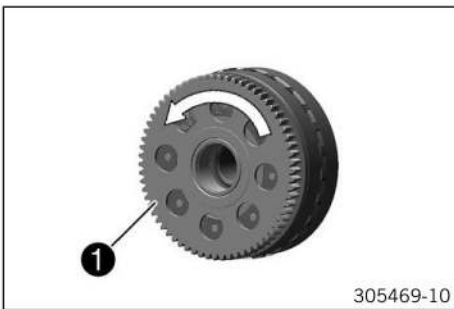

- Insert freewheel gear **1** into the freewheel hub while turning the freewheel gear counterclockwise; do not wedge it.
- Check the locking action of free-wheel-gear **1**.
  - » The freewheel gear cannot be turned counterclockwise and does not block clockwise:
    - Change the freewheel.

## 18.9 Engine assembly

### 18.9.1 Installing the timing chain rails of the left engine case section

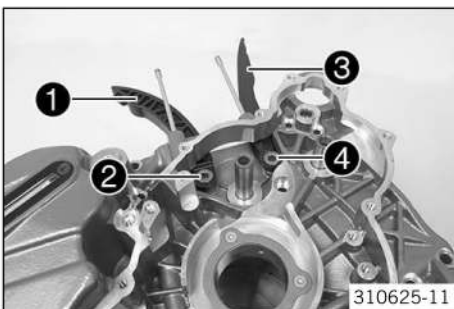

- Position timing chain guide rail **1**. Mount and tighten screw **2**.

Guideline

Screw, timing chain guide rail	M8	15 Nm (11.1 lbf ft)	Loctite® 243™
--------------------------------	----	------------------------	---------------



**Info**

Ensure that there is no thread locker on the collar of the screw; otherwise, the timing chain guide rail may block and brake.

- Position timing chain tensioning rail **3**. Mount and tighten screw **4**.

Guideline

Timing chain tensioning rail screw	M8	15 Nm (11.1 lbf ft)	Loctite® 243™
------------------------------------	----	------------------------	---------------



**Info**

Ensure that there is no thread locker on the collar of the screw; otherwise, the timing chain tensioning rail may block and brake.

- Check both timing chain rails for freedom of motion.

### 18.9.2 Installing the timing chain rails of the right engine case section

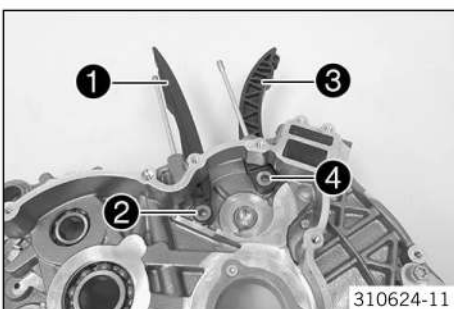

- Position timing chain guide rail **1**. Mount and tighten screw **2**.

Guideline

Screw, timing chain guide rail	M8	15 Nm (11.1 lbf ft)	Loctite® 243™
--------------------------------	----	------------------------	---------------



**Info**

Ensure that there is no thread locker on the collar of the screw; otherwise, the timing chain guide rail may block and brake.

- Position timing chain tensioning rail **3**. Mount and tighten screw **4**.

Guideline

Timing chain tensioning rail screw	M8	15 Nm (11.1 lbf ft)	Loctite® 243™
------------------------------------	----	------------------------	---------------



**Info**

Ensure that there is no thread locker on the collar of the screw; otherwise, the timing chain tensioning rail may block and brake.

- Check both timing chain rails for freedom of motion.

### 18.9.3 Installing the oil spray tube

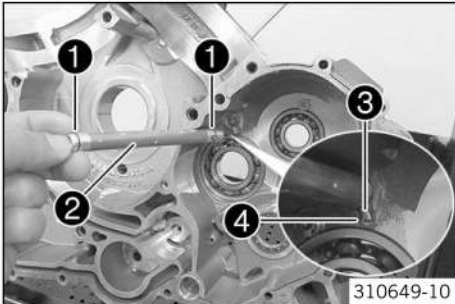

- Mount new O-rings 1 on oil spray tube 2.
- Mount the oil spray tube.
- ✓ Pin 3 must engage in recess 4.

### 18.9.4 Installing the transmission shaft

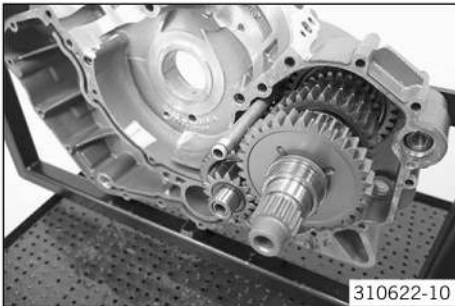

- Clamp the right section of the engine case.

Engine assembly stand (61229001000) (📖 p. 348)
--

Engine fixing arm (61229002000) (📖 p. 348)
--

- Assemble the two transmission shafts and slide them into the bearing seats together.

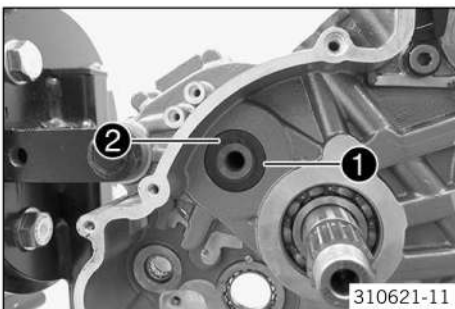

- Mount stop disk 1 and lock ring 2 of the countershaft.

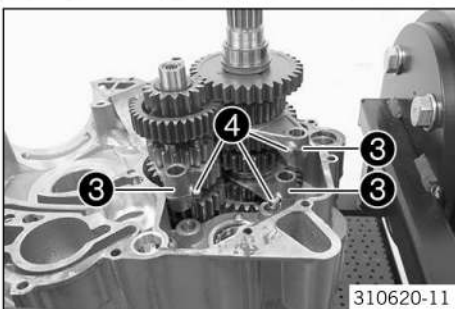

- Tilt the engine.
- Mount shift forks 3 with shift rollers 4.



**Info**

Use a small amount of grease to fix the shift rollers to the shift forks.

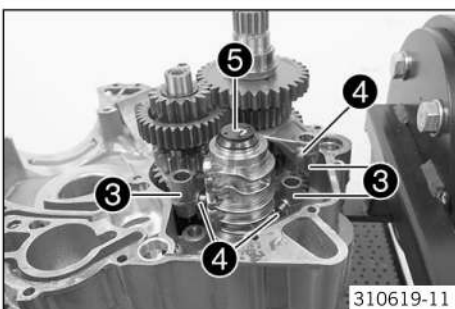

- Swing shift forks 3 to one side.



**Info**

Watch out for the shift rollers 4.

- Insert shift drum 5 into the bearing seat.
- Let the shift forks engage in the shift grooves.

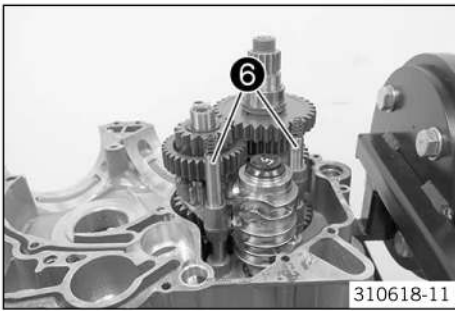

- Mount shift rails **6** with the springs.



**Info**

Affix the springs to the shift rails with grease.

- Check the transmission for smooth operation.

### 18.9.5 Installing the middle suction pump

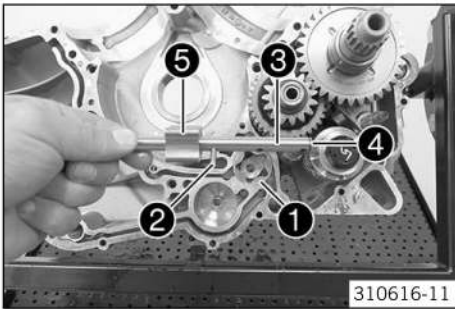

- Mount external rotor **1**.  
✓ The rounded side of the external rotor must face the engine case.
- Mount pin **2** into the third hole of oil pump shaft **3** after shaft keyway **4**.
- Slide internal rotor **5** over the pin.

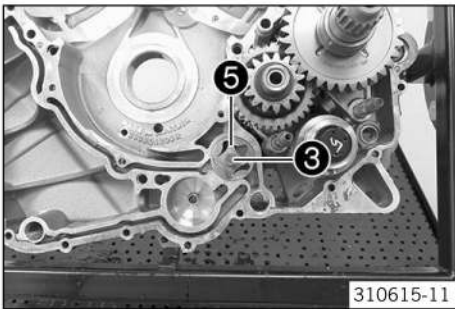

- Mount oil pump shaft **3** with internal rotor **5**.
- Oil the parts.

### 18.9.6 Installing the crankshaft



- Oil the bearing shells.
- Slide the crankshaft into the bearing seat.



**Info**

Position the connecting rod as shown in the photo.

### 18.9.7 Installing the left engine case

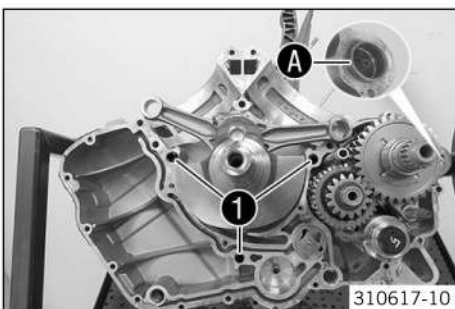

- Mount dowels **1**.
- Check that dowel **A** is correctly seated.

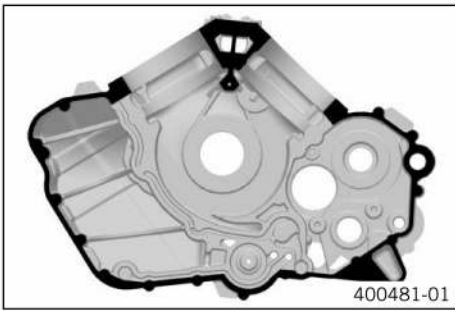

- Degrease the sealing area and coat thinly with sealant.

Loctite® 5910



**Info**

Only coat the sealing area around the outside (see figure).

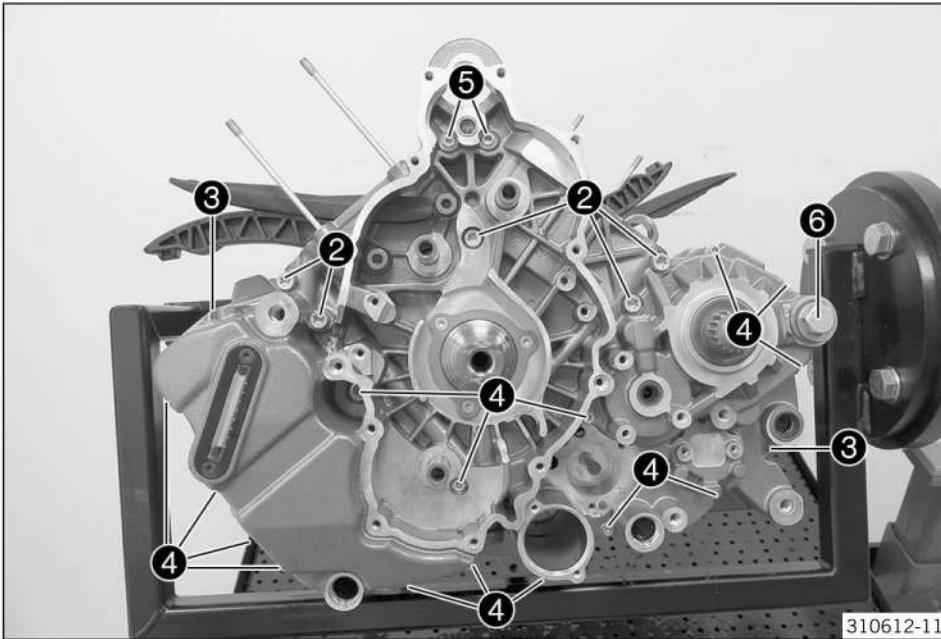

- Attach the left engine case, using a plastic hammer if necessary to seat it properly.



**Info**

Do not tighten the engine case sections using the screws.

- Mount and tighten screws ②.

Guideline

Screw, engine case	M8	18 Nm (13.3 lbf ft)
--------------------	----	---------------------

- Mount and tighten screws ③.

Guideline

Screw, engine case	M6x60	10 Nm (7.4 lbf ft)
--------------------	-------	--------------------

- Mount and tighten screws ④.

Guideline

Screw, engine case	M6x80	10 Nm (7.4 lbf ft)
--------------------	-------	--------------------

- Mount and tighten screws ⑤.

Guideline

Screw, engine case	M6x90	10 Nm (7.4 lbf ft)
--------------------	-------	--------------------



**Info**

Screws ⑤ must always be replaced with new screws.

- Mount screw ⑥.

## 18.9.8 Installing the locking lever

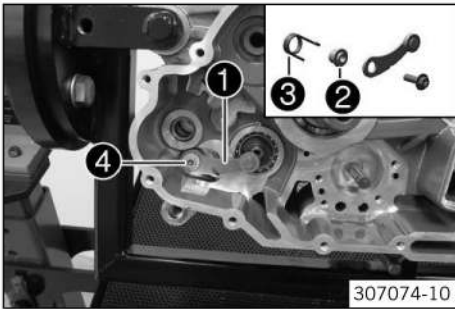

- Position locking lever ① with sleeve ② and spring ③.
- Mount and tighten screw ④.

Guideline

Screw, locking lever	M6	10 Nm (7.4 lbf ft)	Loctite® 243™
----------------------	----	-----------------------	---------------

## 18.9.9 Installing the shift drum locating

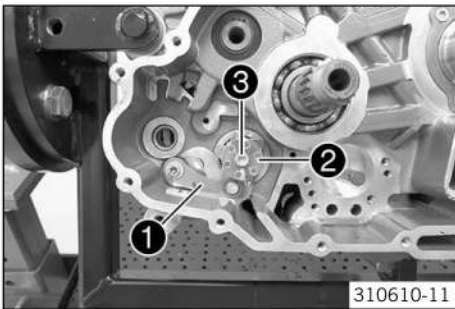

- Press locking lever ① down and position shift drum locating ②.

**i** Info

The flat surfaces of the shift drum locating unit are not symmetric.

- Release the locking lever.
- Mount and tighten screw ③.

Guideline

Screw, shift drum locating	M6	10 Nm (7.4 lbf ft)	Loctite® 243™
----------------------------	----	-----------------------	---------------

## 18.9.10 Installing the shift shaft

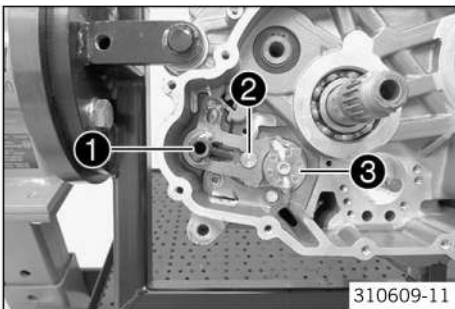

- Slide shift shaft ① with the washer into the bearing seat.
- Push sliding plate ② away from the shift drum locating ③.
- Insert the shift shaft all the way.
- Let the sliding plate engage in the shift drum locating.
- Shift through the transmission.

## 18.9.11 Installing the force pump

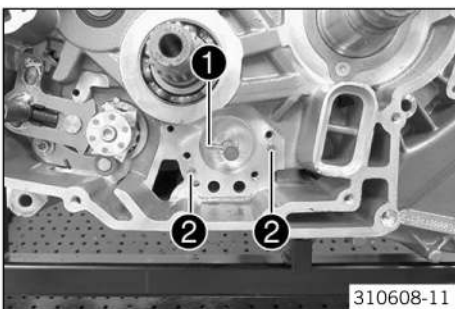

- Mount pin ①.

**i** Info

Ensure that pins ② are seated correctly.

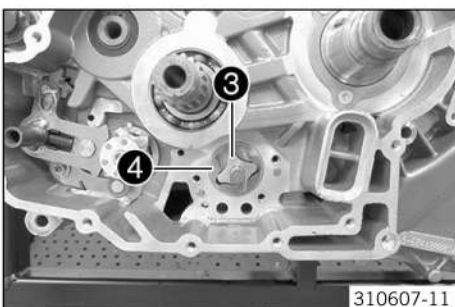

- Mount internal rotor ③ and external rotor ④.
- ✓ The rounded side of the external rotor must face the engine case.
- Oil the parts.

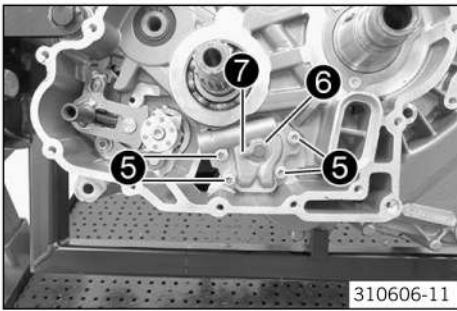

- Position the oil pump cover. Mount and tighten screws 5.

Guideline

Screw, oil pump cover	M6	10 Nm (7.4 lbf ft)	Loctite® 243™
-----------------------	----	-----------------------	---------------

- Mount washer 6 and pin 7.

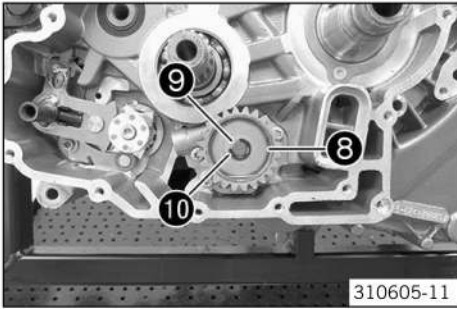

- Mount oil pump gear wheel 8, washer 9 and lock washer 10.

## 18.9.12 Installing the left suction pump

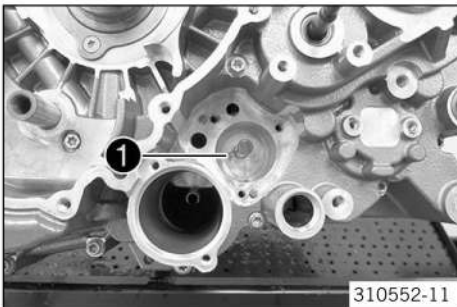

- Mount pin 1.

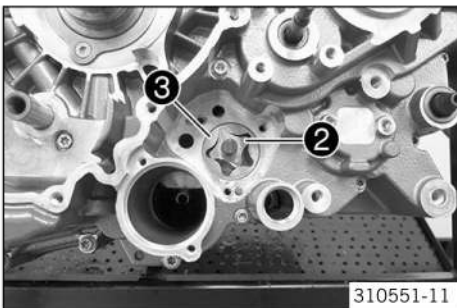

- Mount internal rotor 2 and external rotor 3.
- ✓ The rounded side of the external rotor must face the engine case.
- Oil the parts.

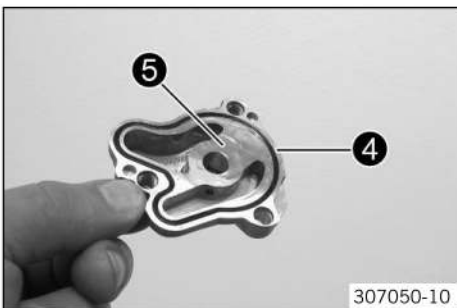

- Insert new gasket 4 into the oil pump cover.
- Position the oil pump cover 5.

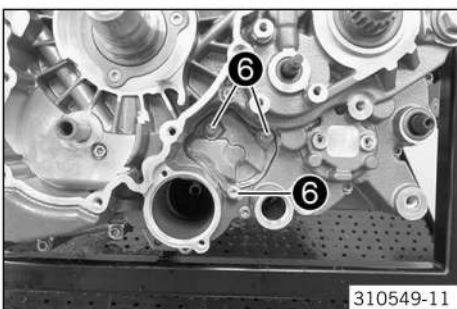

- Mount and tighten screws 6.

Guideline

Screw, oil pump cover	M6	10 Nm (7.4 lbf ft)	Loctite® 243™
-----------------------	----	-----------------------	---------------

- Turn the oil pump gear wheel and check the oil pumps for smooth operation.



## 18.9.13 Setting the engine to ignition top dead center of the rear cylinder

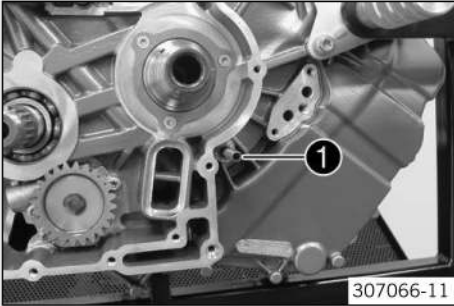

- Set the crankshaft to top dead center of the rear cylinder.
  - ✓ The position notch of the crankshaft is visible in the hole.
- Screw in special tool ①.

Engine blocking screw (61229015000) (📖 p. 349)

## 18.9.14 Installing the primary gear

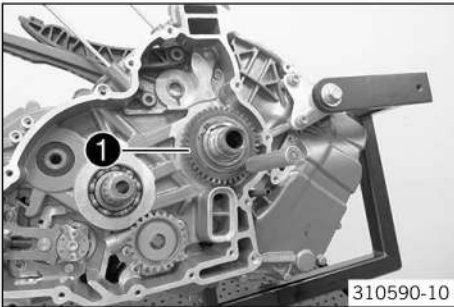

- Ensure that the woodruff key is seated properly.
- Mount primary gear ①.
- Ensure that the spread transmission is pretensioned.
  - » If the spread transmission is not pretensioned:
    - Pretension the spread transmission. (📖 p. 206)

## 18.9.15 Installing the clutch basket

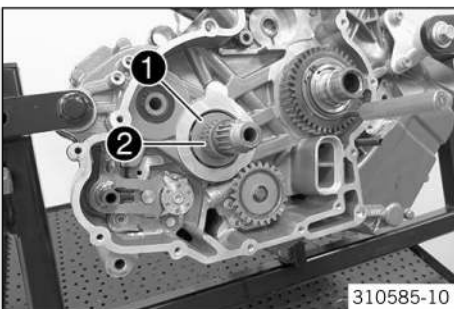

- Mount washer ① and needle bearing ②.

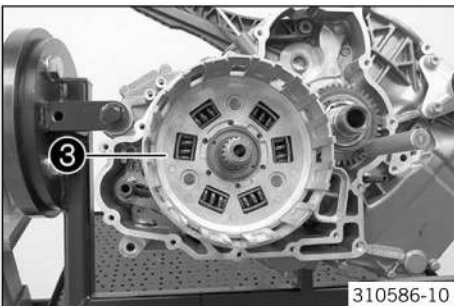

- Mount clutch basket ③ with oil pump drive gear.



### Info

Turn the clutch basket and oil pump gear wheel backwards and forwards slightly to help them mesh more easily.

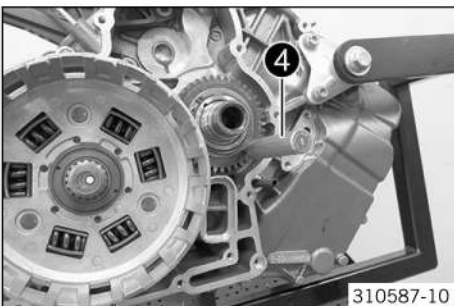

- Remove the special tool ④.

Spread transmission locking pin (61329033000) (📖 p. 352)

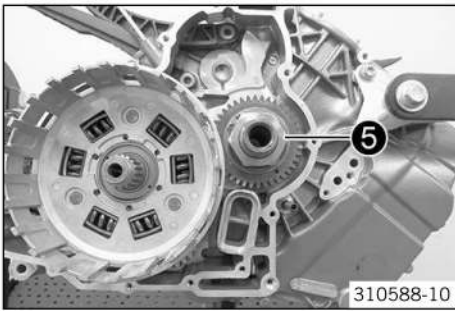

- Mount the washer and nut **5** and tighten the nut.

Guideline

Nut, primary gear	M33LHx1.5	130 Nm (95.9 lbf ft)	Loctite® 243™
-------------------	-----------	-------------------------	---------------

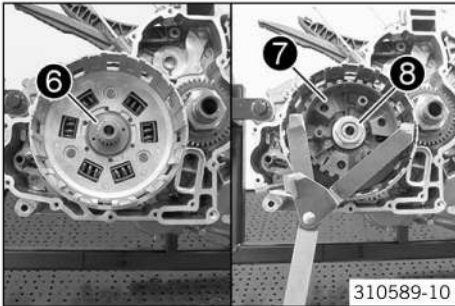

- Mount washer **6**.
- Mount inner clutch hub **7**.
- Mount nut **8** with the washer.
- Tighten the nut, holding the inner clutch hub with a special tool.

Guideline

Nut, inner clutch hub	M22x1.5	120 Nm (88.5 lbf ft)	Loctite® 243™
-----------------------	---------	-------------------------	---------------

Clutch holder (51129003000) (p. 344)

### 18.9.16 Installing the clutch discs

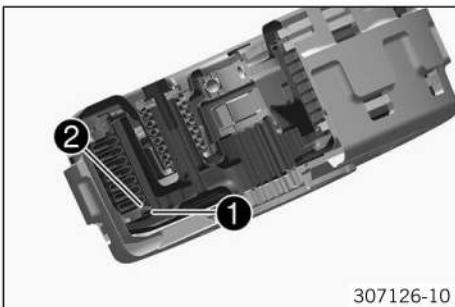

- Mount support ring **1** and pretension ring **2**.
- ✓ The pretension ring rests against the support ring on the inside and the outside faces away from the support ring.

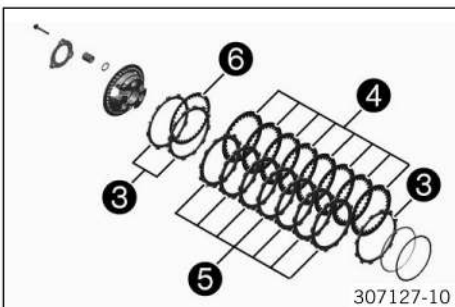

- Thoroughly oil the clutch facing discs.
- Mount a clutch facing disc **3** with a larger inside diameter.
- Alternately mount 8 intermediate clutch discs **4** and 7 of the same clutch facing discs **5**.
- Alternately mount 2 clutch facing discs **3** and an intermediate clutch disc **6** with a larger inside diameter.
- The outer clutch facing disc must be mounted offset by one mesh.

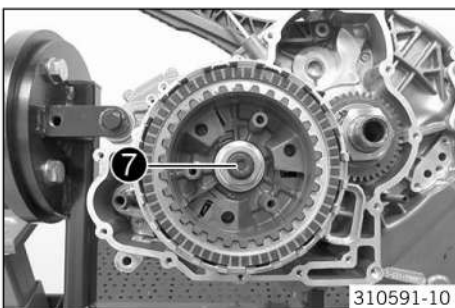

- Mount push rod **7**.

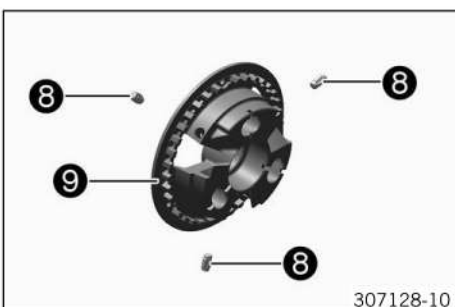

- Mount damper **8** in the clutch pressure cap **9**.

**i** Info

When changing the clutch discs, always renew the damper.

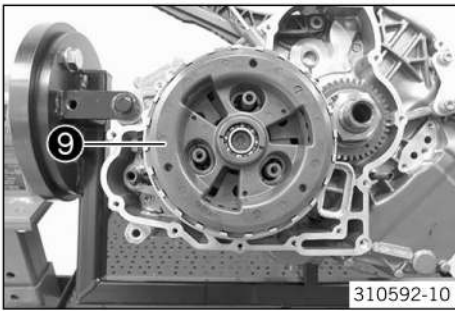

- Position clutch pressure cap **9**.
  - ✓ The teeth of the outer intermediate clutch disc engages in the clutch pressure cap.
  - ✓ The clutch pressure cap rests flush against the outer lining disc.

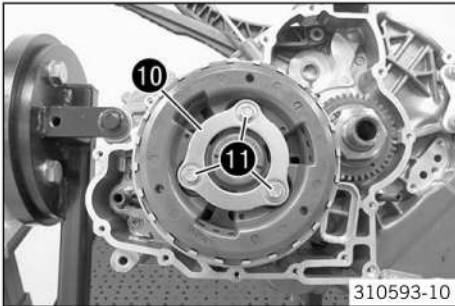

- Position clutch center **10** and the springs.
- Mount and tighten screws **11**.

Guideline

Screw, clutch spring	M6	12 Nm (8.9 lbf ft)
----------------------	----	--------------------

### 18.9.17 Installing the idler and timing chain on the right

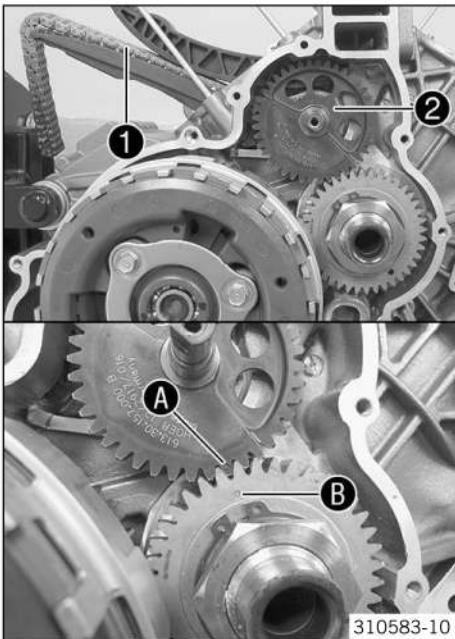

- Position timing chain **1** according to the direction of travel.
- Place the timing chain over the tothing of idler **2**.
  - ✓ Align markings **A** and **B**.
- Slide on the idler.

### 18.9.18 Installing the clutch cover

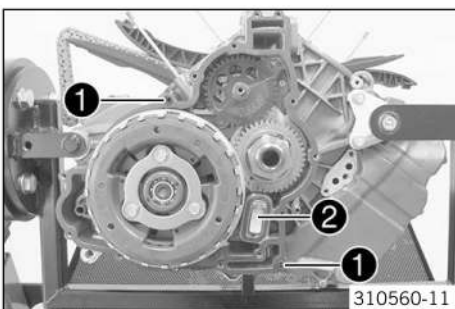

- Mount dowels **1** and position the clutch cover gasket.
- Mount check valve **2**.

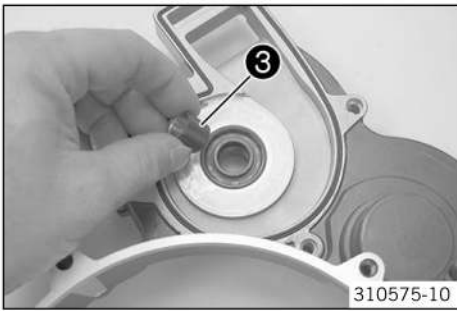

- Position water pump sleeve **3** in both seal rings.

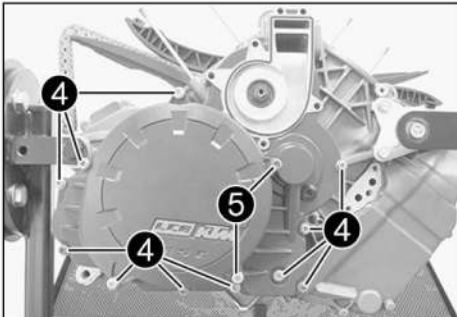

- Mount the clutch cover. Mount and tighten screws **4** and **5**.

Guideline

Screw, clutch cover	M6	10 Nm (7.4 lbf ft)
---------------------	----	--------------------

- Push water pump sleeve **3** all the way.

✓ Water pump sleeve **3** is flush with the recess of the water pump shaft.

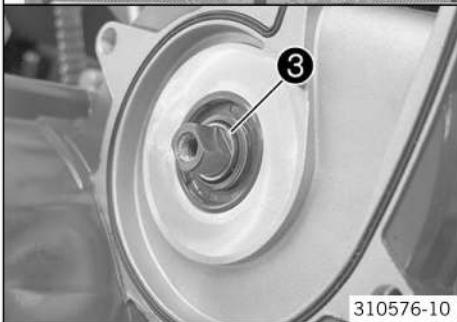

## 18.9.19 Installing the water pump wheel

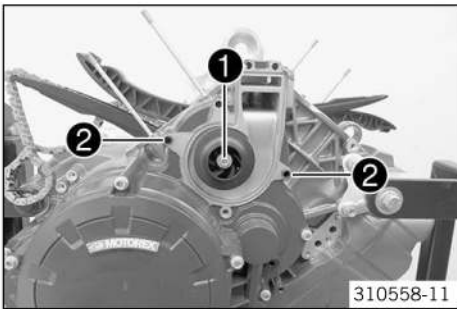

- Mount the washer and water pump wheel.
- Mount and tighten screw **1**.

Guideline

Screw, water pump wheel	M6	10 Nm (7.4 lbf ft)	Loctite® 243™
-------------------------	----	--------------------	---------------

- Mount dowels **2**.
- Replace the seal.

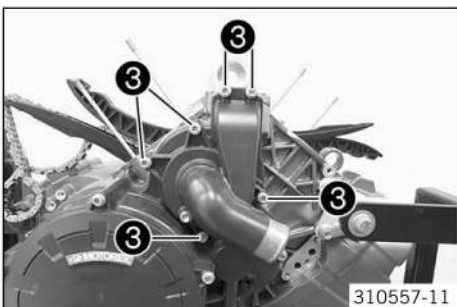

- Mount the water pump cover.
- Mount and tighten screws **3**.

Guideline

Screw, water pump cover	M6	10 Nm (7.4 lbf ft)
-------------------------	----	--------------------

## 18.9.20 Installing the gear position sensor

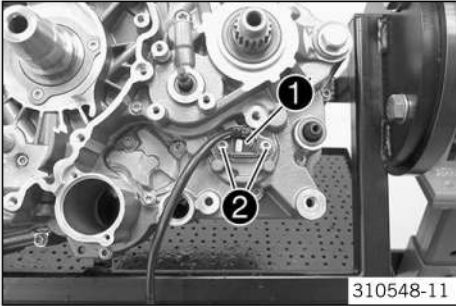

- Position gear position sensor **1**.
- Mount and tighten screws **2** with the washers.

Guideline

Screw, gear sensor	M5	6 Nm (4.4 lbf ft)	Loctite® 243™
--------------------	----	----------------------	---------------

## 18.9.21 Installing the drive wheel of the balancer shaft

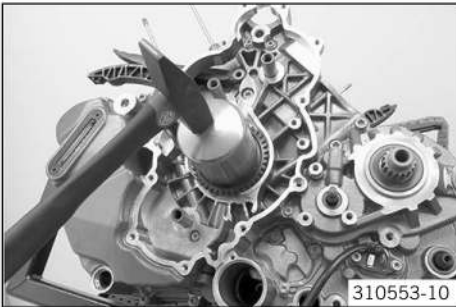

- Heat the drive wheel of the balancer shaft.

Guideline

200 °C (392 °F)

- Ensure that the woodruff key is seated properly. Mount the drive wheel of the balancer shaft with the beveled edge facing forward.

Pressure bell (61229016000) (☞ p. 349)

- ✓ The markings are visible after mounting.

## 18.9.22 Installing the balancer shaft

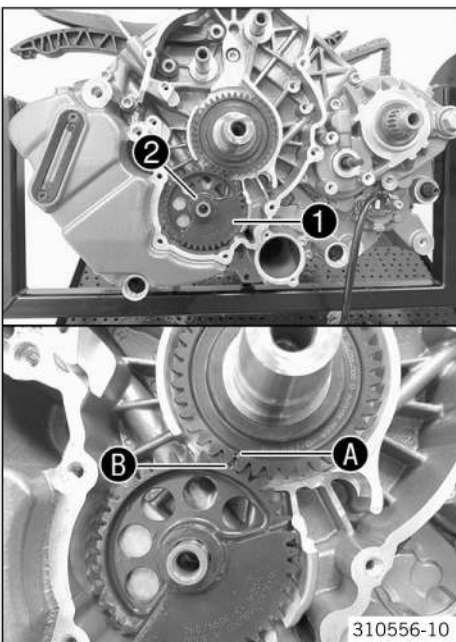

- Mount the rear washer and needle bearing.
- Mount balancer shaft **1**.
- ✓ Markings **A** and **B** are aligned.
- Mount washer **2**.

## 18.9.23 Installing the idler and timing chain on the left

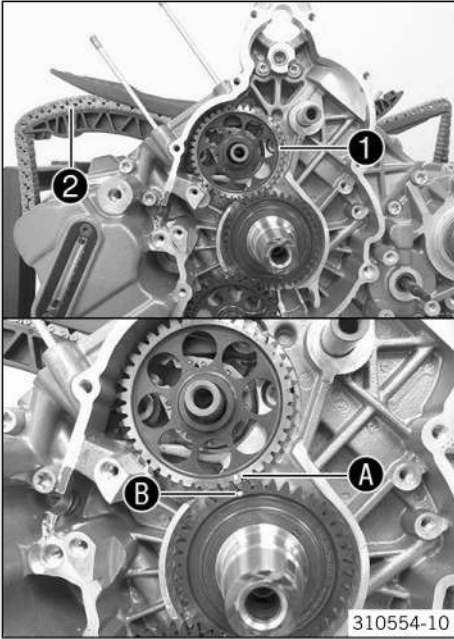

- Mount the rear washer.
- Mount idle gear ① with timing chain ② in accordance with the direction of travel.
- ✓ Markings A and B are aligned.

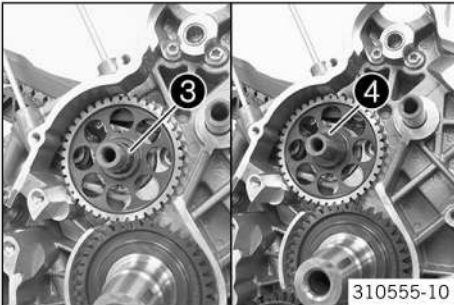

- Mount needle bearing ③.



**Info**

For easier assembly, loosen the engine blocking screw.

- Mount washer ④.

## 18.9.24 Installing the oil filter

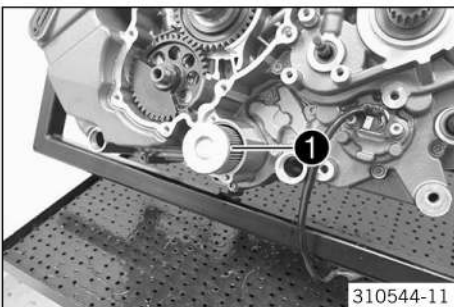

- Tilt the engine sideways and fill the oil filter housing to about 1/3 full with engine oil.
- Insert oil filter ①.

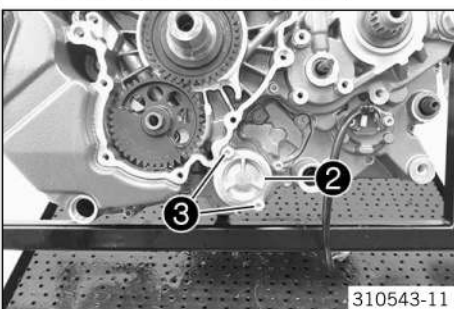

- Lubricate the O-ring of oil filter cover ②. Mount the oil filter cover.
- Mount and tighten screws ③.

Guideline

Remaining engine screws	M5	6 Nm (4.4 lbf ft)
-------------------------	----	-------------------

## 18.9.25 Installing the rotor

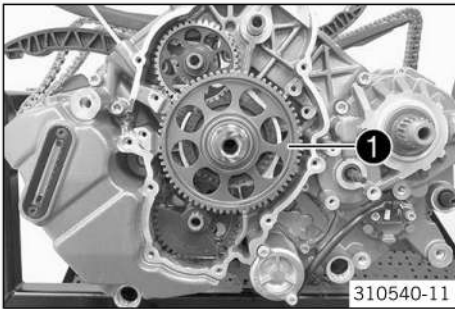

- Mount freewheel gear **1**.

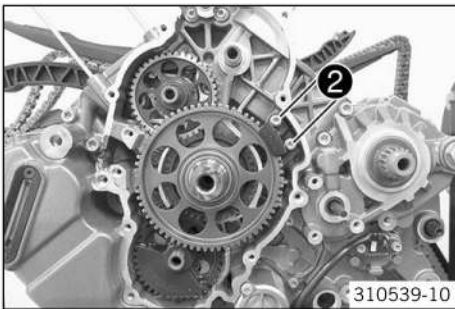

- Position freewheel holder **2**. Mount and tighten the screws.

Guideline

Screw, freewheel holder	M6	10 Nm (7.4 lbf ft)	Loctite® 243™
-------------------------	----	-----------------------	---------------

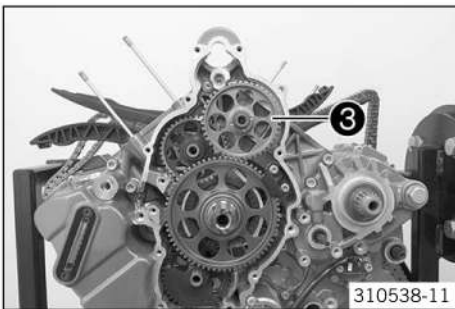

- Mount the rear washer, needle bearing, idler **3** and front washer.

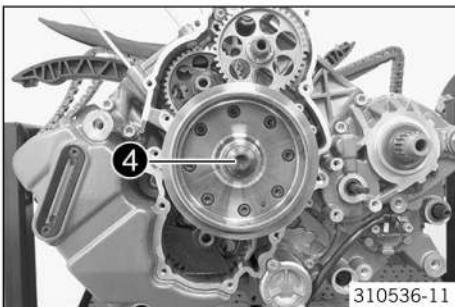

- Mount the rotor.

**i** Info

Ensure that the woodruff key is seated properly.  
For easier mounting, turn the idler gear counterclockwise.

- Mount and tighten rotor screw **4**.

Guideline

Rotor screw	M12x1.5	90 Nm (66.4 lbf ft)
-------------	---------	------------------------

## 18.9.26 Installing the torque limiter

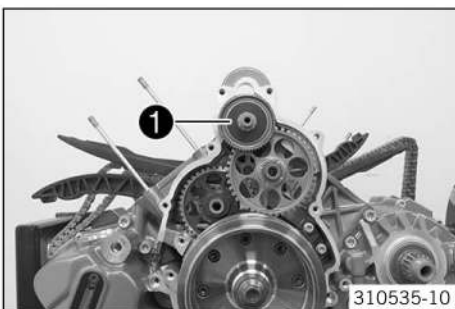

- Mount torque limiter **1** with the rear washer.

## 18.9.27 Installing the ignition pulse generator

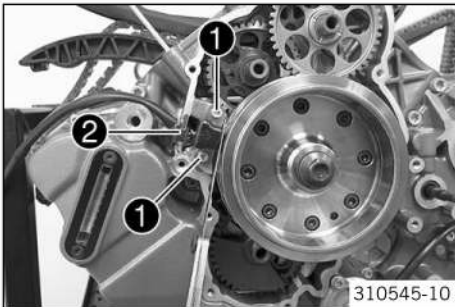

- Position the crankshaft position sensor.
- Mount screws **1**, but do not tighten yet.

Guideline

Screw, pulse generator	M5	6 Nm (4.4 lbf ft)	Loctite® 243™
------------------------	----	----------------------	---------------

- Position the cable, thinly coat cable support sleeve **2** with the sealing compound and insert it in the engine case.

Loctite® 5910

- Adjust the distance between the crankshaft position sensor and the conductive element of the rotor using the special tool.

Guideline

Crankshaft position sensor/rotor - gap	0.40 mm (0.0157 in)
--	---------------------

Feeler gauge (59029041100) (📖 p. 346)

- Tighten screws **1**.

Guideline

Screw, pulse generator	M5	6 Nm (4.4 lbf ft)	Loctite® 243™
------------------------	----	----------------------	---------------

## 18.9.28 Installing the alternator cover

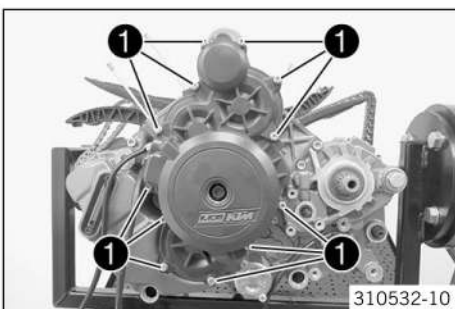

- Mount the new alternator cover seal and dowels.
- Position the alternator cover.
- Mount and tighten screws **1**.

Guideline

Remaining engine screws	M6	10 Nm (7.4 lbf ft)
-------------------------	----	--------------------

## 18.9.29 Rear piston assembly



- Adjust impact of the piston rings by 120°.
- Mount oiled piston in the special tool.

Piston assembly ring (61329015108) (📖 p. 351)



- Position the special tool on the cylinder with the piston.
- Slide the piston carefully into the cylinder.
- ✓ The piston rings may not be left hanging, as they may be damaged.



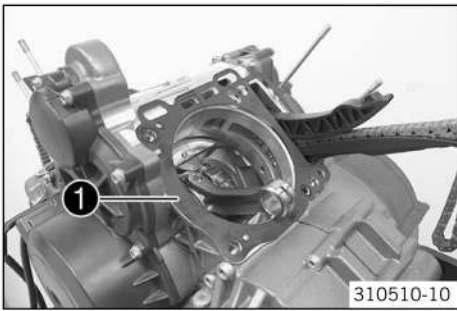

- Place the new cylinder base gasket **1** into position.

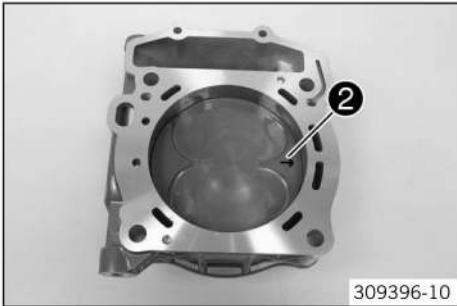

- Ensure that piston marking **2** faces the exhaust side.

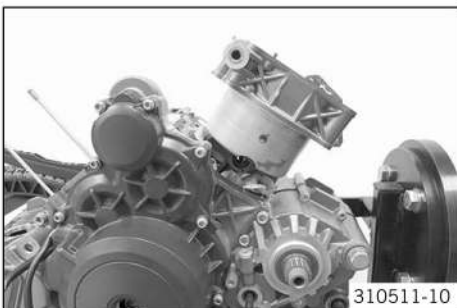

- Cover the engine case opening with a cloth. Thread the timing chain through the timing chain shaft. Mount the piston pin.

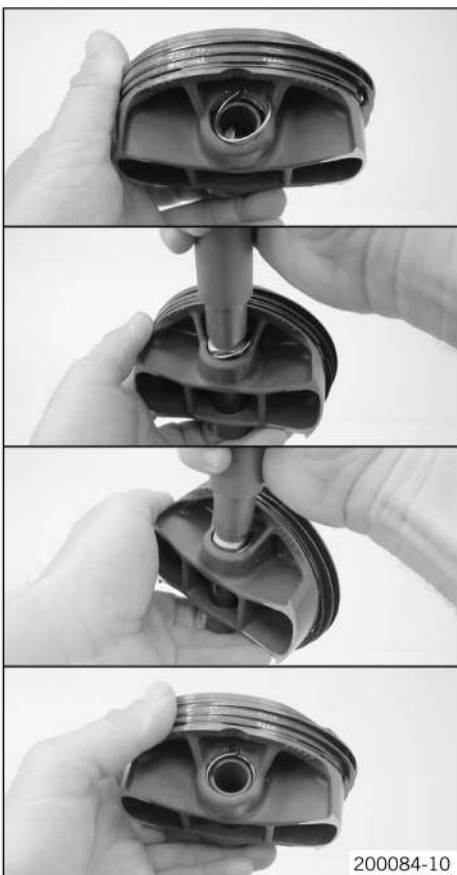

- Position the new piston ring lock.



**Info**

For purposes of illustration, the following operations are shown on the deinstalled piston.

- Insert the special tool and press it with force towards the piston.
- Turn the special tool counterclockwise and, in doing so, press the piston ring lock into the groove.

Insertion tool for piston ring lock (75029035000) (📖 p. 353)

- Ensure that the piston ring lock is in the correct position on both sides.

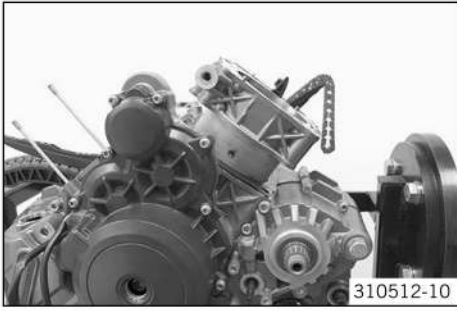

- Remove the cloth.
- Keep the timing chain taut. Press the cylinder down carefully and bring dowel pins into contact.

### 18.9.30 Installing the rear cylinder head

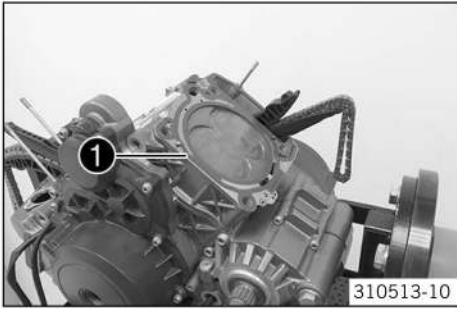

- Put on cylinder head gasket **1**.

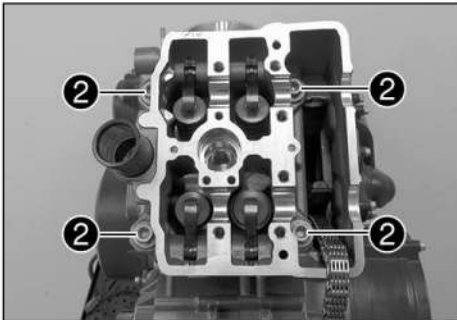

- Position the cylinder head and mount and tighten the new cylinder head screws **2** with washers.

Guideline

Cylinder head screw	M11x1.5	Tightening sequence: Using a criss-cross pattern Step 1 15 Nm (11.1 lbf ft) Step 2 30 Nm (22.1 lbf ft) Step 3 90° Step 4 90°	Lubricated with engine oil
---------------------	---------	---	----------------------------

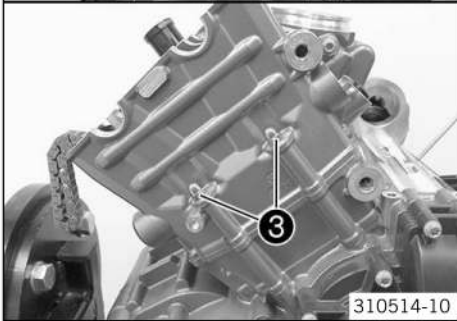

- Mount and tighten nuts **3** with the washers.

Guideline

Nut, cylinder head	M6	9 Nm (6.6 lbf ft)
--------------------	----	-------------------

## 18.9.31 Installing the rear camshafts

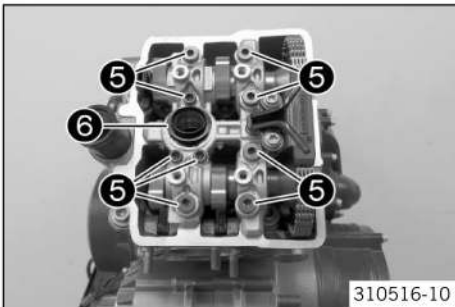
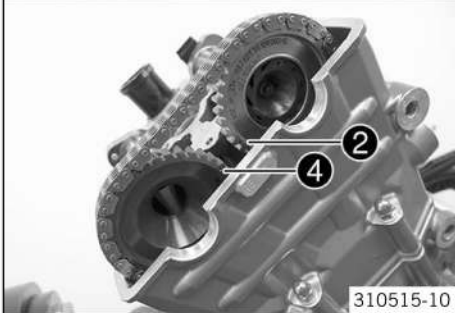
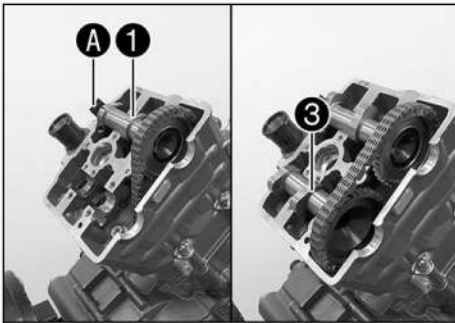

- Pull up the timing chain and insert intake camshaft **1**.



**Info**

The intake camshaft is labeled with **eh**.

- Place the timing chain over the rear sprocket of the intake camshaft.
  - ✓ Marking **2** is aligned.
- Ensure that bleeder **A** is seated correctly.
- Position exhaust camshaft **3**.



**Info**

The exhaust camshaft is labeled with **ah**.

- Place the timing chain over the rear sprocket and position the camshaft in the bearing seat.
  - ✓ Marking **4** is aligned.

- Thoroughly clean all oil nozzles and blow them out with compressed air.
- Position the camshaft bearing bridge.
- Mount screws **5** and tighten them from the inside to the outside.

Guideline

Screw, camshaft bearing support	M6 – 10.9	10 Nm (7.4 lbf ft)
Screw, camshaft bearing support	M8 – 10.9	Step 1 10 Nm (7.4 lbf ft) Step 2 18 Nm (13.3 lbf ft)

- Grease the O-rings and mount spark plug shaft insert **6**.

## 18.9.32 Installing the rear timing chain tensioner

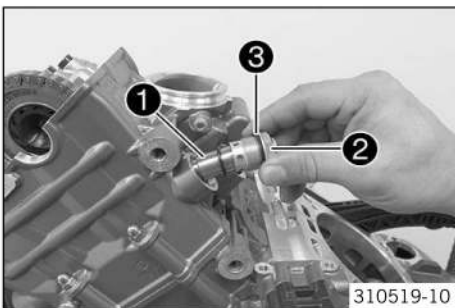

- After it has been positioned in the installation location, insert timing chain tensioner **1** with a new O-ring.
- Mount and tighten screw plug **2** with new O-ring **3**.

Guideline

Plug, timing-chain tensioner	M24x1.5	25 Nm (18.4 lbf ft)
------------------------------	---------	------------------------

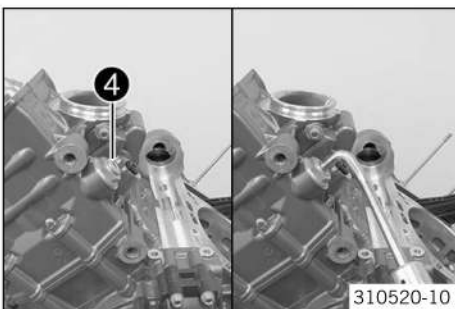

- Remove screw **4** with O-ring and use the special tool to push the timing chain tensioner toward the timing chain.

Release device for timing chain tensioner (61229021000) (📄 p. 350)

- ✓ The timing chain tensioner unlocks.
- Mount and tighten screw **4** with new O-ring.

Guideline

Screw, timing chain tensioner release	M10x1	10 Nm (7.4 lbf ft)
---------------------------------------	-------	--------------------

## 18.9.33 Setting the engine to ignition top dead center of the front cylinder

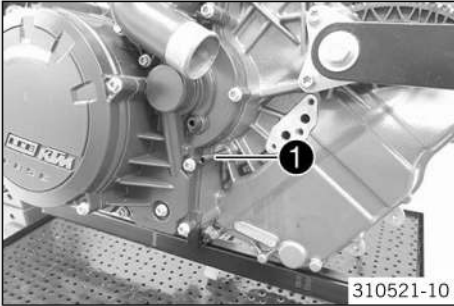

- Remove special tool **1**.
- Keep the timing chain tensioned.
- Turn the crankshaft counterclockwise by the specified value.

Guideline

1 turn

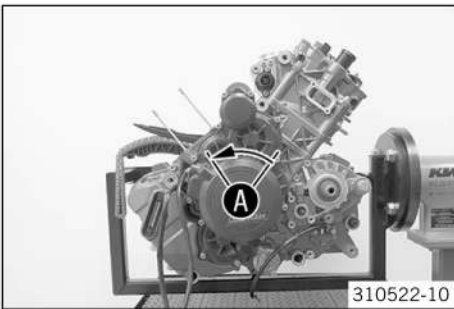

- Turn the crankshaft counterclockwise by the specified value **A**.

Guideline

75°

- ✓ The position notch of the crankshaft is visible in the hole.

- Screw in special tool **1**.

Engine blocking screw (61229015000) (p. 349)

## 18.9.34 Installing the front piston



- Shift the joint of the piston rings by 120°.
- Mount the oiled piston in the special tool.

Piston assembly ring (61329015108) (p. 351)



- Position the special tool on the cylinder with the piston.
- Slide the piston carefully into the cylinder.
- ✓ The piston rings should not become caught; otherwise, they may be damaged.

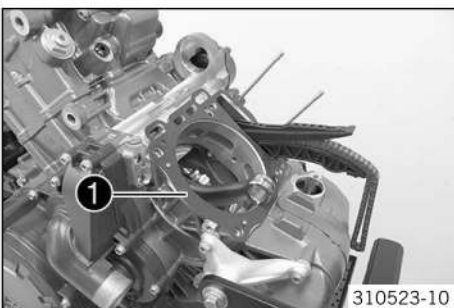

- Position the new cylinder base gasket **1**.

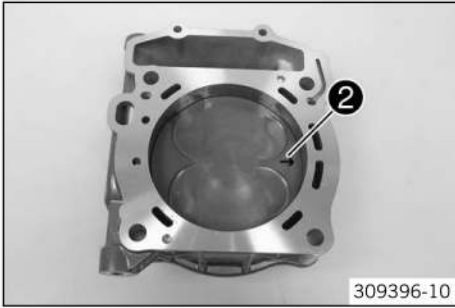

- Ensure that piston marking ② faces the outfeed side.

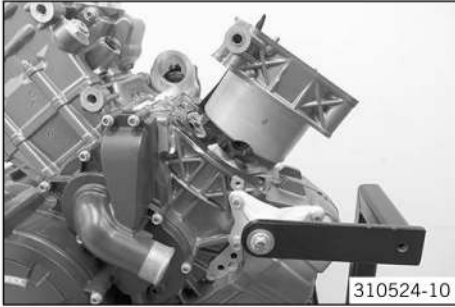

- Cover the engine case opening with a cloth. Thread the timing chain through the timing chain shaft. Mount the piston pin.



- Position the new piston pin retainer.

**i Info**

For clarity, the following steps are illustrated using a disassembled piston.



- Insert the special tool and firmly press it toward the piston.
- Turn the special tool counterclockwise, thereby pressing the piston pin retainer into the groove.

Insertion tool for piston ring lock (75029035000) (p. 353)



- Ensure that the piston pin retainer is correctly seated on both sides.

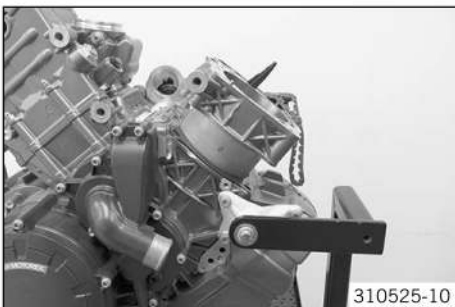

- Remove the cloth.
- Keep the timing chain tensioned. Push the cylinder down carefully and let the dowel pins engage.

## 18.9.35 Installing the front cylinder head

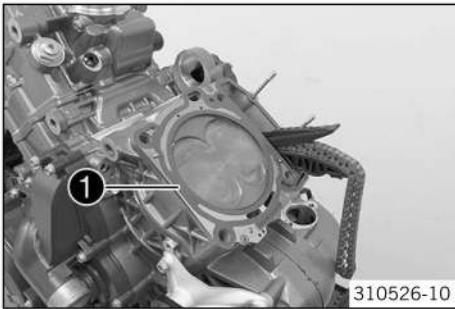

- Put on cylinder head gasket **1**.

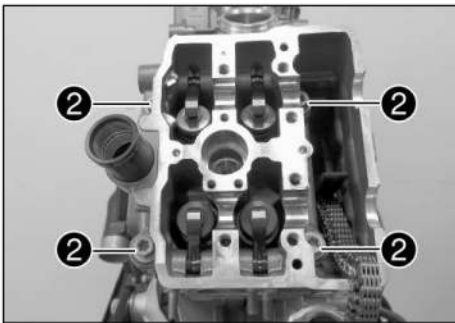

- Put the cylinder head in place. Mount and tighten the new cylinder head screws **2** with washers.

### Guideline

Cylinder head screw	M11x1.5	Tightening sequence: Using a criss-cross pattern Step 1 15 Nm (11.1 lbf ft) Step 2 30 Nm (22.1 lbf ft) Step 3 90° Step 4 90°	Lubricated with engine oil
---------------------	---------	---	----------------------------

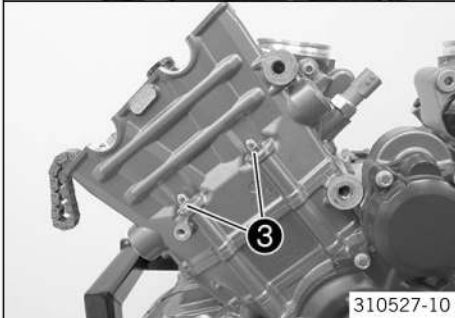

- Mount and tighten nuts **3** with the washers.

### Guideline

Nut, cylinder head	M6	9 Nm (6.6 lbf ft)
--------------------	----	-------------------

## 18.9.36 Installing the front camshafts

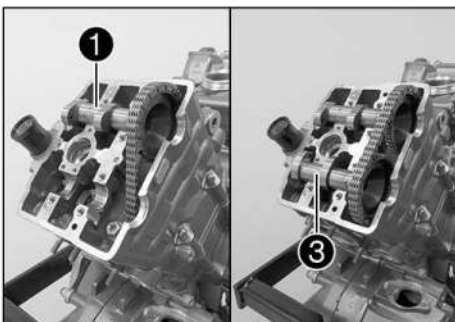

- Pull up the timing chain and insert intake camshaft **1**.



**Info**  
The intake camshaft is labeled with **ev**.

- Place the timing chain over the rear sprocket of the intake camshaft.  
✓ Marking **2** is aligned.
- Position exhaust camshaft **3**.



**Info**  
The exhaust camshaft is labeled with **av**.

- Place the timing chain over the rear sprocket and position the camshaft in the bearing seat.  
✓ Marking **4** is aligned.

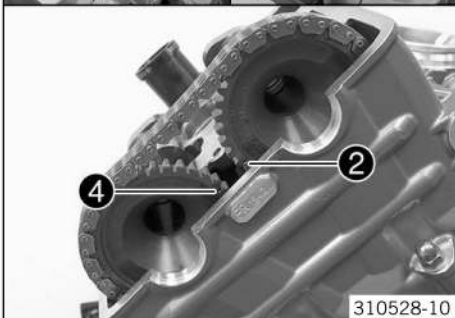

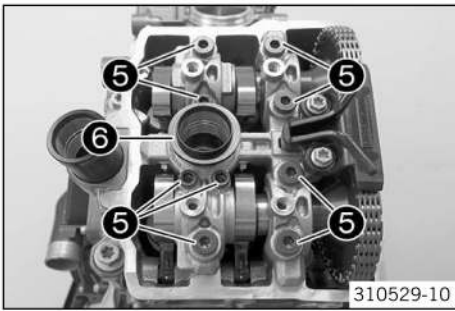

- Thoroughly clean all oil nozzles and blow them out with compressed air.
- Position the camshaft bearing bridge.
- Mount screws **5** and tighten them from the inside to the outside.

Guideline

Screw, camshaft bearing support	M6 – 10.9	10 Nm (7.4 lbf ft)
Screw, camshaft bearing support	M8 – 10.9	Step 1 10 Nm (7.4 lbf ft) Step 2 18 Nm (13.3 lbf ft)

- Grease the O-rings and mount spark plug shaft insert **6**.

### 18.9.37 Installing the front timing chain tensioner

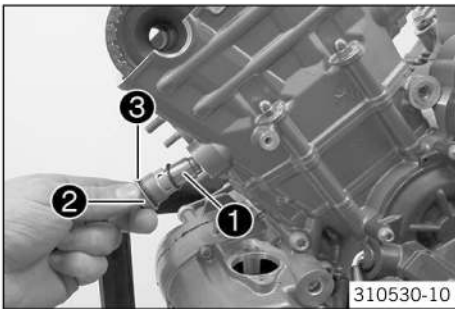

- After it has been positioned in the installation location, insert timing chain tensioner **1** with a new O-ring.
- Mount and tighten screw plug **2** with new O-ring **3**.

Guideline

Plug, timing-chain tensioner	M24x1.5	25 Nm (18.4 lbf ft)
------------------------------	---------	------------------------

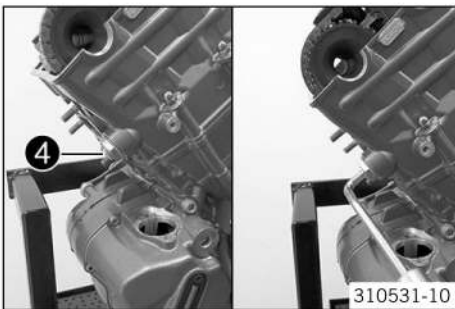

- Remove screw **4** with O-ring and use the special tool to push the timing chain tensioner toward the timing chain.

Release device for timing chain tensioner (61229021000) (p. 350)

- ✓ The timing chain tensioner is unlocked.
- Mount and tighten screw **4** with new O-ring.

Guideline

Screw, timing chain tensioner release	M10x1	10 Nm (7.4 lbf ft)
---------------------------------------	-------	--------------------

### 18.9.38 Installing the heat exchanger

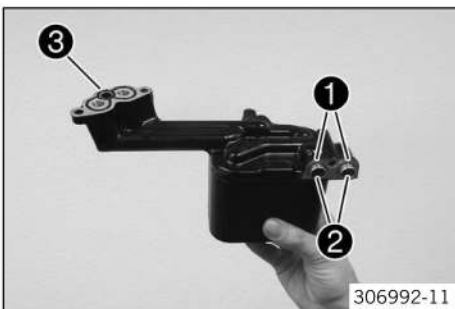

- Oil and mount O-rings **1**.
- Mount sleeves **2**.
- Mount gasket **3**.

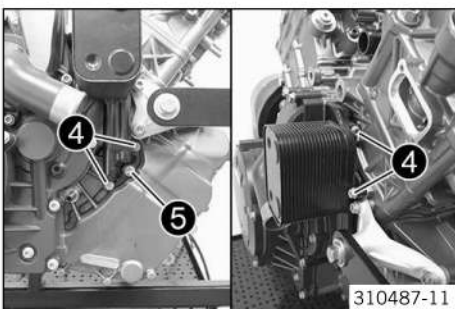

- Position the heat exchanger.
- Mount and tighten screws **4**.

Guideline

Remaining engine screws	M6	10 Nm (7.4 lbf ft)
-------------------------	----	--------------------

- Mount and tighten screw **5**.

Guideline

Screw, heat exchanger	M8	15 Nm (11.1 lbf ft)
-----------------------	----	------------------------

## 18.9.39 Installing the starter motor

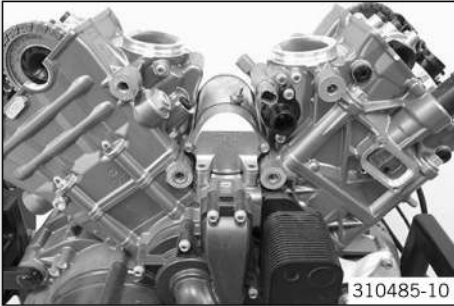

- Grease the O-ring. Position the starter motor.

Long-life grease (📖 p. 340)



### Info

The screws are mounted only in the vehicle.

## 18.9.40 Checking the rear valve clearance

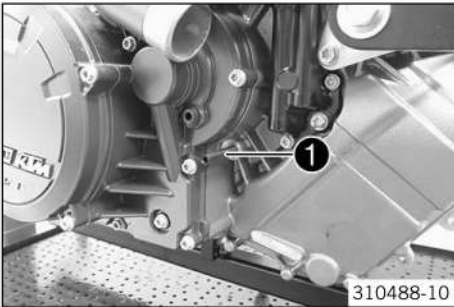

- Remove special tool **1**.

Engine blocking screw (61229015000) (📖 p. 349)

- Crank the engine several times.
- Set the engine to ignition top dead center of the rear cylinder. (📖 p. 171)

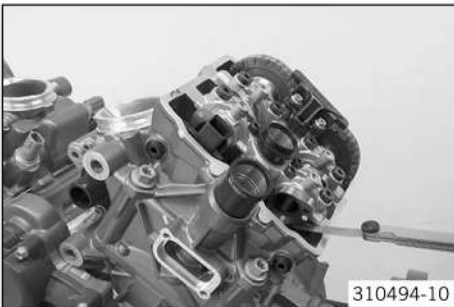

- On all valves, check the valve clearance between the camshaft and cam lever.

### Guideline

Valve clearance	
Exhaust at: 20 °C (68 °F)	0.25... 0.30 mm (0.0098... 0.0118 in)
Intake at: 20 °C (68 °F)	0.10... 0.15 mm (0.0039... 0.0059 in)

Feeler gauge (59029041100) (📖 p. 346)

- » If valve clearance does not meet specifications:
  - Adjust the rear valve clearance. (📖 p. 238)

## 18.9.41 Adjusting the rear valve clearance

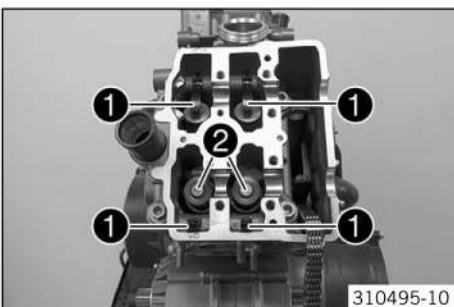

- Remove the rear timing chain tensioner. (📖 p. 172)
- Remove the rear camshaft. (📖 p. 173)
- Swing up cam lever **1**.
- Remove shims **2** and set them down according to the installation position.
- Correct the shims as indicated by the results of the valve clearance check.
- Insert suitable shims.
- Install the rear camshaft. (📖 p. 233)
- Install the rear timing chain tensioner. (📖 p. 233)
- Check the rear valve clearance. (📖 p. 238)

## 18.9.42 Checking the front valve clearance



- Remove the special tool.

Engine blocking screw (61229015000) (📖 p. 349)

- Crank the engine several times.
- Set the engine to ignition top dead center of the front cylinder. (📖 p. 174)
- On all valves, check the valve clearance between the camshaft and cam lever.



Guideline

Valve clearance	
Exhaust at: 20 °C (68 °F)	0.25... 0.30 mm (0.0098... 0.0118 in)
Intake at: 20 °C (68 °F)	0.10... 0.15 mm (0.0039... 0.0059 in)

Feeler gauge (59029041100) (🔧 p. 346)

- » If valve clearance does not meet specifications:
  - Adjust the front valve clearance. (🔧 p. 239)

### 18.9.43 Adjusting the front valve clearance

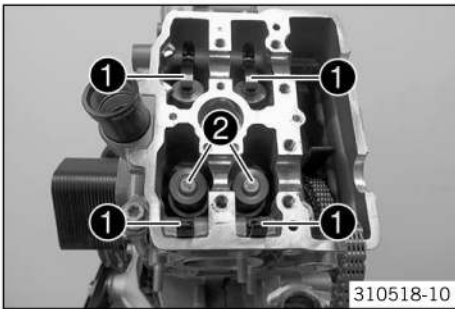

310518-10

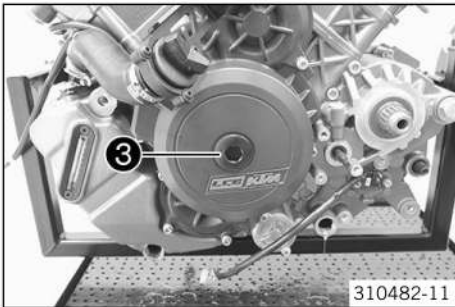

310482-11

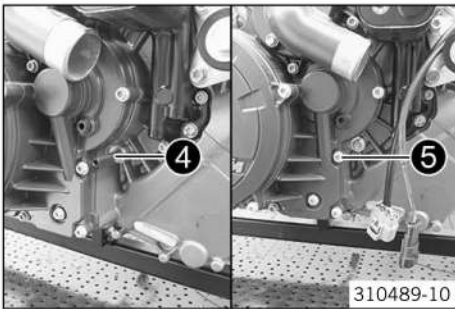

310489-10

- Remove the front timing chain tensioner. (🔧 p. 174)
- Remove the front camshafts. (🔧 p. 175)
- Swing up cam lever ①.
- Remove shims ② and set them down according to the installation position.
- Correct the shims as indicated by the results of the valve clearance check.
- Insert suitable shims.
- Install the front camshafts. (🔧 p. 236)
- Install the front timing chain tensioner. (🔧 p. 237)
- Check the front valve clearance. (🔧 p. 238)

- Mount and tighten the screw of alternator cover ③.

Guideline

Screw in alternator cover	M24x1.5	8 Nm (5.9 lbf ft)
---------------------------	---------	-------------------

- Remove special tool ④. Mount and tighten screw ⑤.

Guideline

Plug, crankshaft retainer	M8	15 Nm (11.1 lbf ft)
---------------------------	----	---------------------

### 18.9.44 Installing the oil filler tube

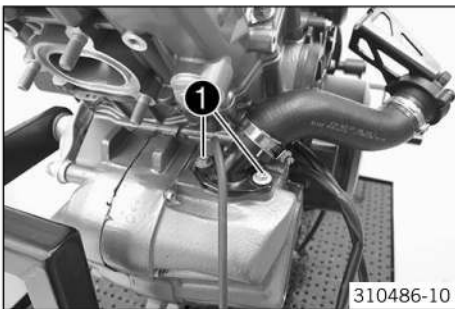

310486-10

- Mount the oil filler tube with the O-ring.
- Mount and tighten screws ①.

Guideline

Remaining engine screws	M6	10 Nm (7.4 lbf ft)
-------------------------	----	--------------------

## 18.9.45 Installing front valve cover

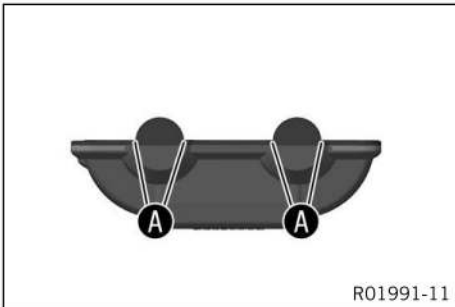

- Clean and degrease the valve cover seal.
- Apply a thin layer of sealant to area **A**.

**Loctite® 5910**

**i Info**

The rear valve cover is equipped with a connector for the engine vent.  
The front valve cover is not equipped with a connector for the engine vent.

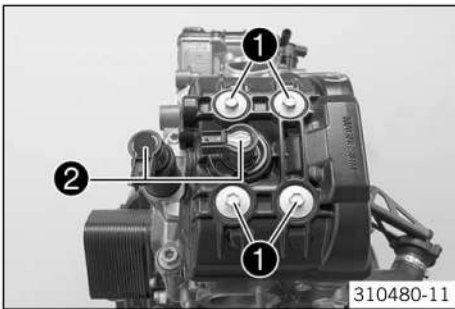

- Put the valve cover in place with the gasket. Mount and tighten screws **1**.

Guideline

Screw, valve cover	M6	10 Nm (7.4 lbf ft)
--------------------	----	--------------------

**i Info**

The front valve cover is not equipped with a connector for the engine vent.

- Mount and tighten the spark plugs using a special tool.

Guideline

Spark plug	M12x1.5	18 Nm (13.3 lbf ft)
Spark plug	M10x1	11 Nm (8.1 lbf ft)

Spark plug wrench (75029172000) (📖 p. 353)

- Mount ignition coils **2**.

## 18.9.46 Installing rear valve cover

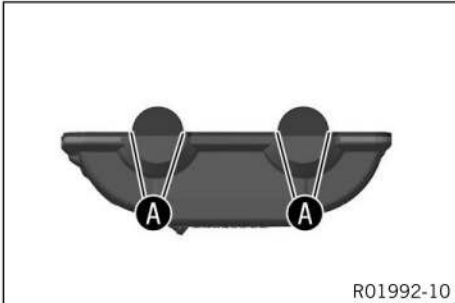

- Clean and degrease the valve cover seal.
- Apply a thin layer of sealant to area **A**.

**Loctite® 5910**

**i Info**

The rear valve cover is equipped with a connector for the engine vent.  
The front valve cover is not equipped with a connector for the engine vent.

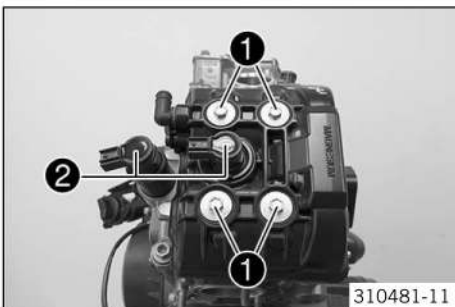

- Put the valve cover in place with the gasket. Mount and tighten screws **1**.

Guideline

Screw, valve cover	M6	10 Nm (7.4 lbf ft)
--------------------	----	--------------------

- Mount and tighten the spark plugs using a special tool.

Guideline

Spark plug	M12x1.5	18 Nm (13.3 lbf ft)
Spark plug	M10x1	11 Nm (8.1 lbf ft)

Spark plug wrench (75029172000) (📖 p. 353)

- Mount ignition coils **2**.

## 18.9.47 Installing the oil drain plug

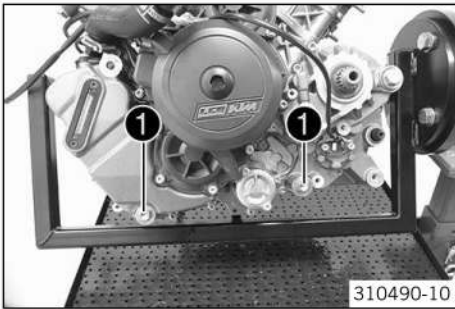

- Mount the new O-rings.
- Mount and tighten oil drain plug ① with the magnet, O-rings and oil screen.

Guideline

Oil drain plug	M20x1.5	20 Nm (14.8 lbf ft)
----------------	---------	------------------------

## 18.9.48 Mounting the engine bearer

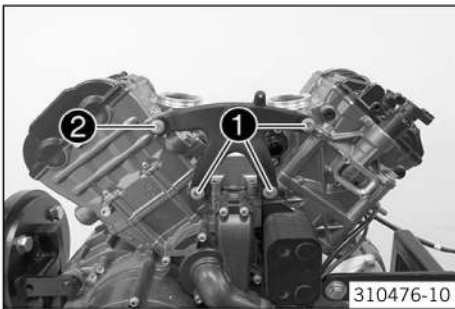

- Position the engine bearer.
- Mount and tighten screws ① and ②.

Guideline

Screw, engine bearer	M10	45 Nm (33.2 lbf ft)
----------------------	-----	------------------------

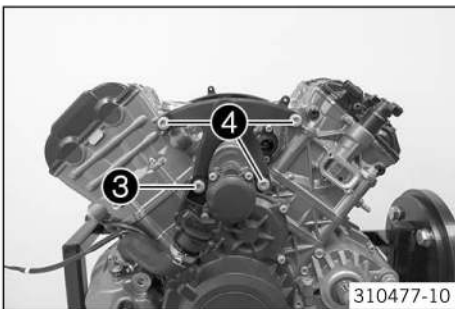

- Position engine bearer and oil filler tube.
- Mount screw ③ but do not tighten yet.

Guideline

Screw, engine bearer	M10	45 Nm (33.2 lbf ft)
----------------------	-----	------------------------

- Mount and tighten screws ④.

Guideline

Screw, engine bearer	M10	45 Nm (33.2 lbf ft)
----------------------	-----	------------------------

- Tighten screw ③.

Guideline

Screw, engine bearer	M10	45 Nm (33.2 lbf ft)
----------------------	-----	------------------------

## 18.9.49 Removing the engine from the engine assembly stand



- Remove the screw connections.
- Remove the engine from the engine assembly stand.



### Info

Have an assistant help you or use a crane.

## 19.1 Changing the SAS membrane

### Preparatory work

- Remove the passenger seat. (📖 p. 72)
- Remove the front rider's seat. (📖 p. 71)
- Remove the crash bar. (📖 p. 32)
- Remove the front side cover. (📖 p. 87)
- Remove the tank cover. (📖 p. 89)
- Remove the mask spoiler. (📖 p. 90)
- Remove the fuel tank. (📖 p. 73)

### Main work

- Remove screws ❶.
- Pull off the cover and hang it to one side.

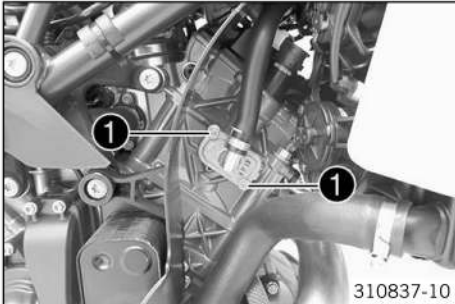

- Remove SAS membrane ❷.
- Mount the new SAS membrane.
- ✓ The SAS membrane is positioned flush in the cylinder.

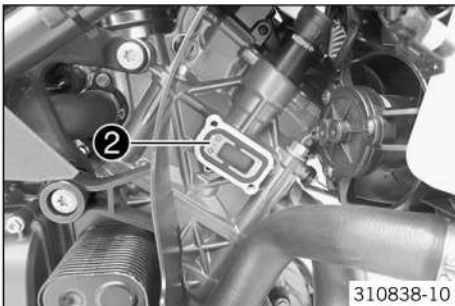

- Position the cover.
- Mount and tighten screws ❶.

#### Guideline

Remaining screws, engine	M6	10 Nm (7.4 lbf ft)
--------------------------	----	--------------------

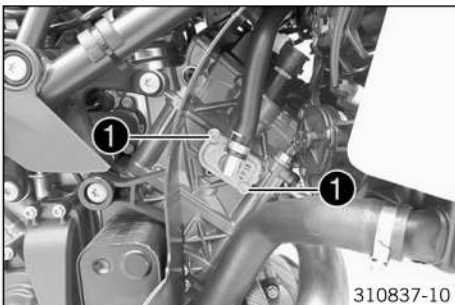

- Remove screws ❸.
- Pull off the cover and hang it to one side.

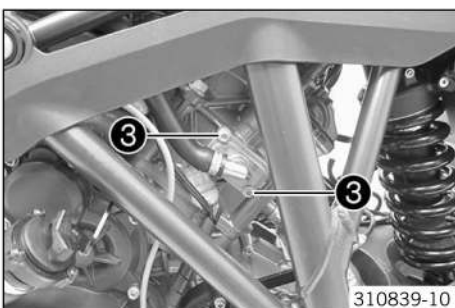

- Remove SAS membrane ❹.
- Mount the new SAS membrane.
- ✓ The SAS membrane is positioned flush in the cylinder.

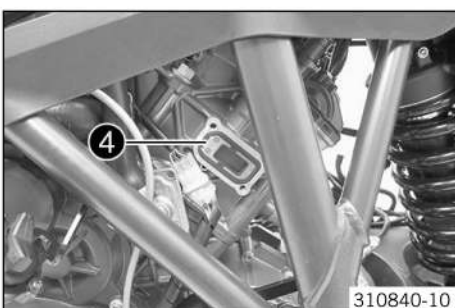

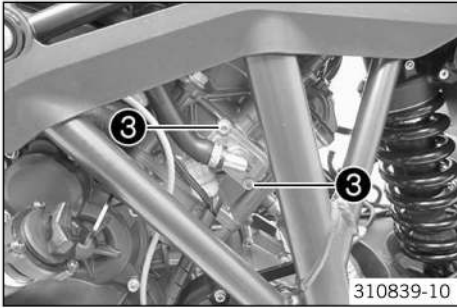

- Position the cover.
- Mount and tighten screws ③.

Guideline

Remaining screws, engine	M6	10 Nm (7.4 lbf ft)
--------------------------	----	--------------------

**Finishing work**

- Install the fuel tank. (📖 p. 74)
- Install the mask spoiler. (📖 p. 92)
- Install the tank cover. (📖 p. 89)
- Install the front side cover. (📖 p. 87)
- Install the crash bar. (📖 p. 32)
- Mount the front rider's seat. (📖 p. 71)
- Mount the passenger seat. (📖 p. 72)

## 20.1 Checking/rectifying the fluid level of the hydraulic clutch

**i Info**  
The fluid level rises with increasing wear of the clutch lining disc.  
Do not use brake fluid.

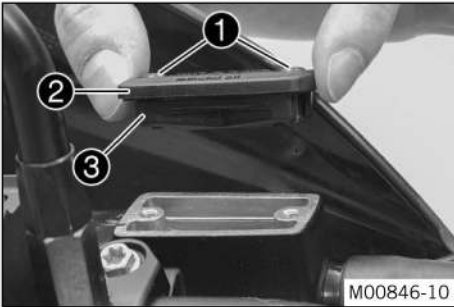

- Move the clutch fluid reservoir mounted on the handlebar to a horizontal position.
- Remove screws **1**.
- Remove cover **2** with membrane **3**.
- Check the fluid level.

Fluid level below top edge of container	4 mm (0.16 in)
---	----------------

- » If the coolant level does not meet specifications:
  - Correct the fluid level of the hydraulic clutch.

Hydraulic fluid (15) (📖 p. 339)
---------------------------------

- Position the cover with the membrane. Mount and tighten the screws.

## 20.2 Changing the hydraulic clutch fluid

**Warning**  
**Environmental hazard** Hazardous substances cause environmental damage.

- Dispose of oils, grease, filters, fuel, cleaning agents, brake fluid, etc., correctly and in compliance with the applicable regulations.

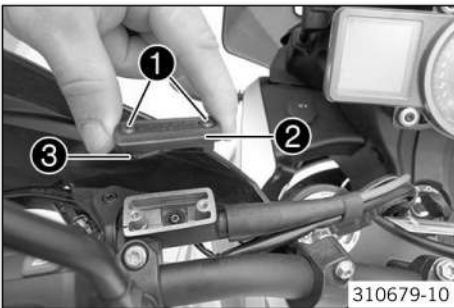

- Move the clutch fluid reservoir mounted on the handlebar to a horizontal position.
- Remove screws **1**.
- Remove cover **2** with membrane **3**.



- Fill bleeding syringe **4** with the appropriate hydraulic fluid.

Bleed syringe (50329050000) (📖 p. 344)
--

Hydraulic fluid (15) (📖 p. 339)
---------------------------------

- On the slave cylinder, remove bleeder screw and mount bleeding syringe **4**.

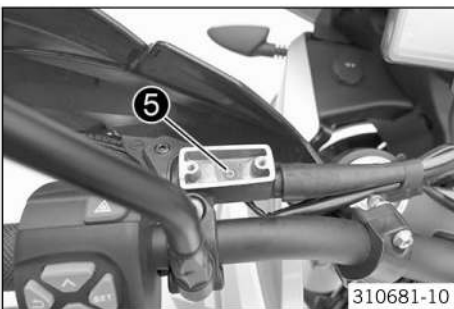

- Inject the liquid into the system until it escapes from hole **5** of the master cylinder without bubbles.
- To prevent overflow, drain fluid occasionally from the master cylinder reservoir.
- Remove the bleeding syringe. Mount and tighten the bleeder screw.
- Correct the fluid level of the hydraulic clutch.

Guideline

Fluid level below container rim	4 mm (0.16 in)
---------------------------------	----------------

- Position the cap with the membrane. Mount and tighten the screws.

## 20.3 Checking the clutch

**Warning**  
**Danger of scalding** Engine and gear oil get very hot when the motorcycle is ridden.

- Wear suitable protective clothing and safety gloves.
- In the event of scalding, rinse the area affected immediately with lukewarm water.

**Warning**  
**Environmental hazard** Hazardous substances cause environmental damage.

- Dispose of oils, grease, filters, fuel, cleaning agents, brake fluid, etc., correctly and in compliance with the applicable regulations.

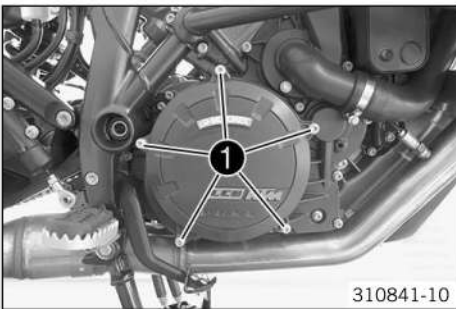

### Main work

- Place a suitable container under the engine.
- Remove screws **1**.
- Take off outer clutch cover.

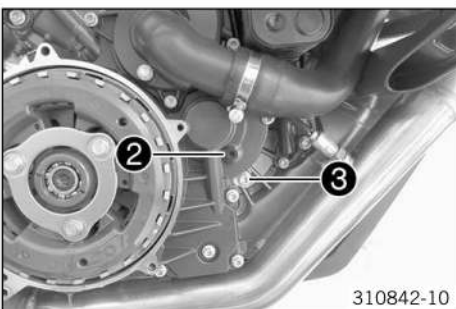

- Remove screw **2**.
- Mount and tighten screw **3** with the washer.

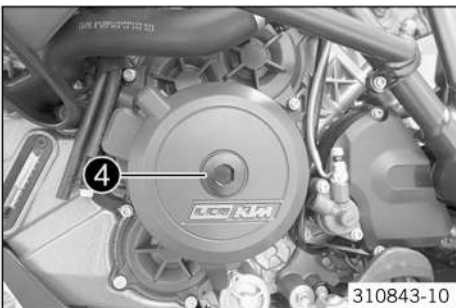

- Remove screw **4**.

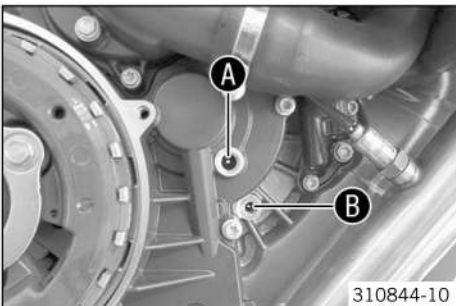

- Turn the crankshaft counterclockwise until holes **A** and **B** are visible.

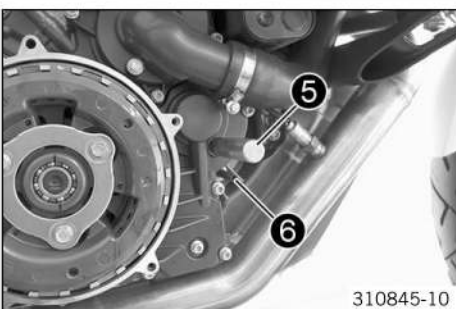

- Mount special tool **5** until it stops.

Spread transmission locking pin (61329033000) (p. 352)

- Screw in special tool **6**.

Engine blocking screw (61229015000) (p. 349)

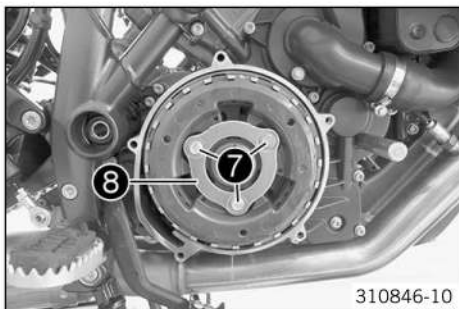

- Remove screws 7.
- Take off clutch center 8 and the springs.

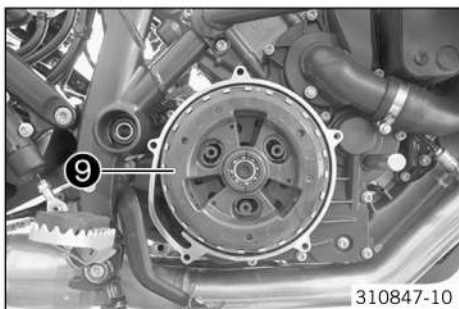

- Remove clutch pressure cap 9.

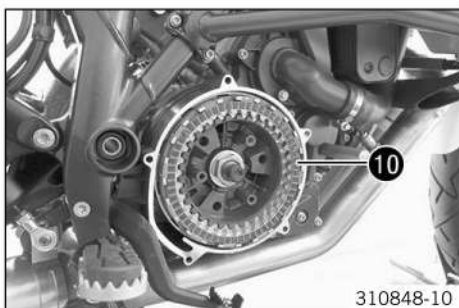

- Remove clutch discs 10, support ring, and pretension ring.

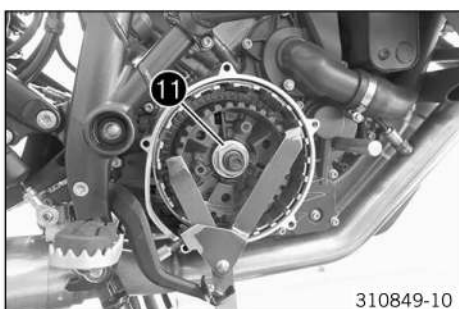

- Hold the inner clutch hub with the special tool.

Clutch holder (51129003000) (p. 344)

- Remove nut 11 with the washer.

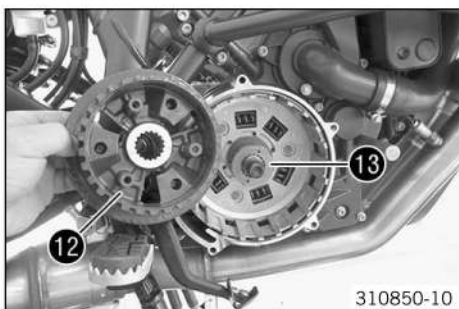

- Take off inner clutch hub 12 and washer 13.

**i** **Info**

The washer usually sticks to the inner clutch hub.

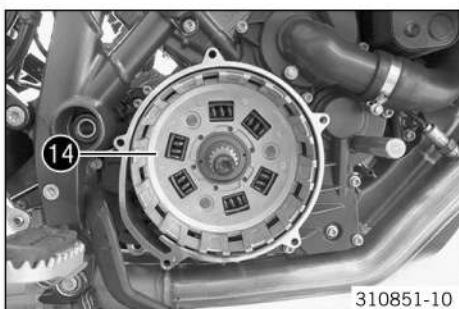

- Remove clutch basket 14 with oil pump drive gear.

**i** **Info**

Ensure that the spread transmission is blocked.



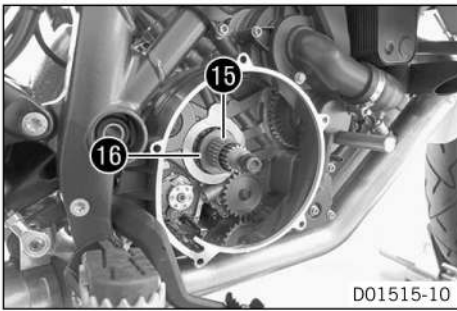

- Remove needle bearing **15** and washer **16**.

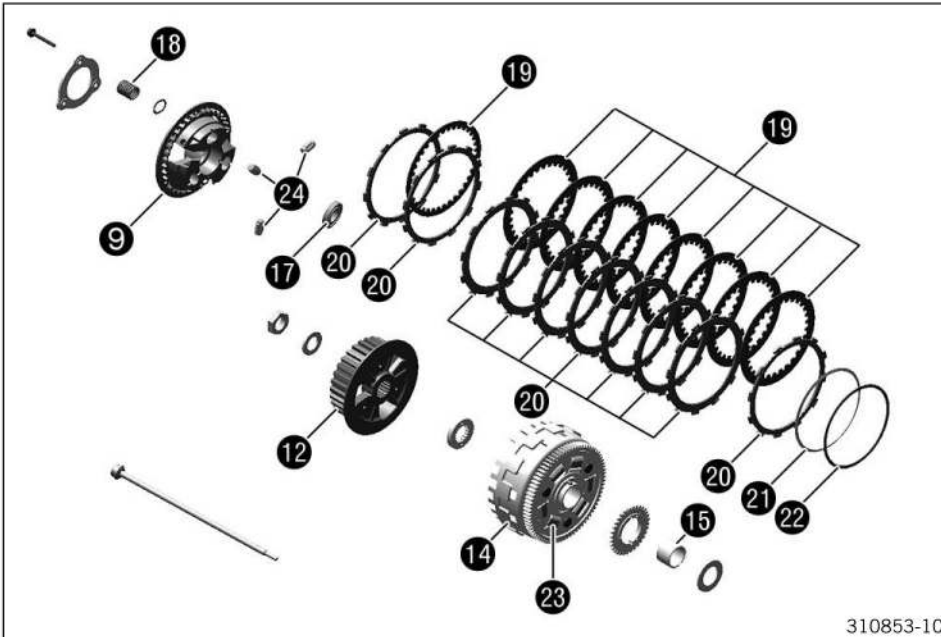

- Check axial bearing **17** for damage and wear.
  - » If there is damage or wear:
    - Change the axial bearing.
- Check the length of clutch springs **18**.
- Check the contact surface of clutch pressure cap **9** for damage and wear.
  - » If there is damage or wear:
    - Change the clutch pressure cap.
- Check the thrust surfaces of the clutch facing discs in clutch basket **14** for wear.

Clutch spring - length	≥ 43.0 mm (≥ 1.693 in)
------------------------	------------------------

- » If the clutch spring length is shorter than specified:
  - Change all clutch springs.

Clutch basket - thrust surface of clutch facing discs	
Wear limit	0.5 mm (0.02 in)

- » If the thrust surface exhibits excessive wear:
  - Change the clutch pack and clutch basket.
- Check needle bearing **15** for damage and wear.
  - » If there is damage or wear:
    - Change the needle bearing.
- Check intermediate clutch discs **19** for damage and wear.
  - » If the intermediate clutch discs are not level and are pitted:
    - Change the clutch pack.
- Check clutch facing discs **20** for discoloration and scoring.
  - » If there is discoloration or scoring:
    - Change the clutch pack.

- Check the thickness of the clutch pack.

Clutch pack - thickness	
New condition	48.00... 47.2 mm (1.8898... 1.858 in)
Wear limit	46.00 mm (1.811 in)

- » If the clutch pack does not meet specifications:
  - Change the clutch pack.
- Check pretension ring **21** and support ring **22** for damage and wear.
  - » If there is damage or wear:
    - Change the pretension ring and support ring.
- Check inner clutch hub **12** for damage and wear.
  - » If there is damage or wear:
    - Change the inner clutch hub.
- Check springs **23** of the clutch basket for damage and wear.
  - » If there is damage, wear or play in the direction of rotation:
    - Change the clutch basket.
- Check damper **24** for damage and wear.

**i** **Info**

If the clutch pressure cap can be mounted without resistance from the damper, the dampers are too hard and are worn out.

- » If there is damage or wear:
  - Change the damper.

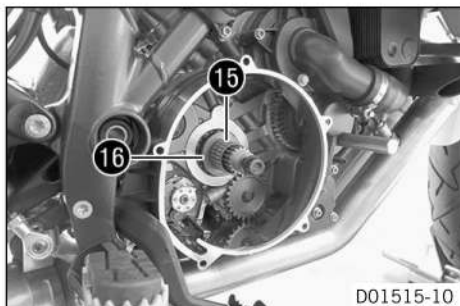

- Mount washer **16** and needle bearing **15**.

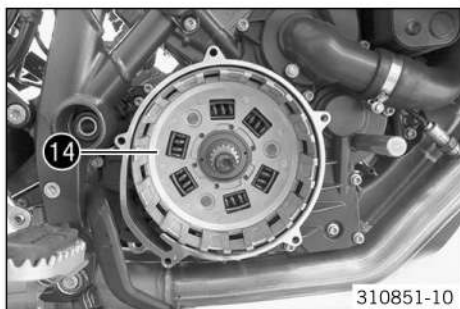

- Mount clutch basket **14** with oil pump drive gear.

**i** **Info**

Turn the clutch basket and oil pump gear wheel backwards and forwards slightly to help them mesh more easily.

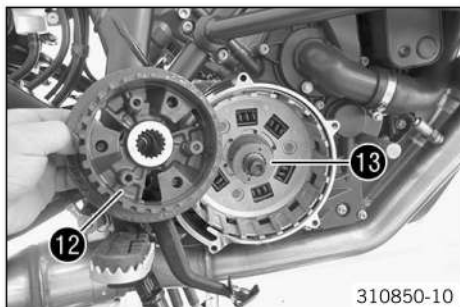

- Mount washer **13**.
- Mount inner clutch hub **12**.

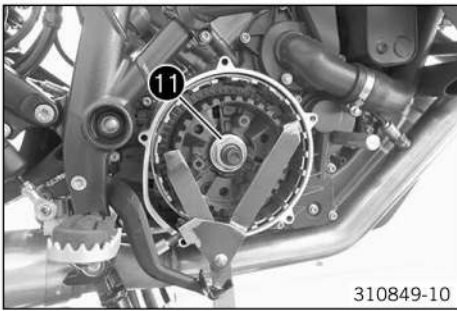

- Mount nut **11** with the washer.
- Tighten the nut, holding the inner clutch hub with a special tool.

Guideline

Nut, inner clutch hub	M22x1.5	120 Nm (88.5 lbf ft)	Loctite® 243™
Clutch holder (51129003000) (圖 p. 344)			

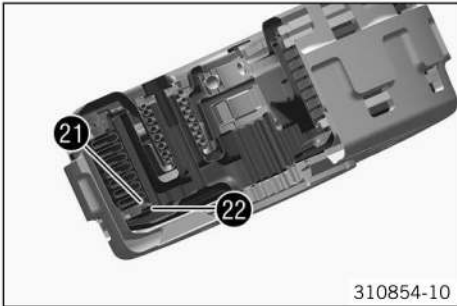

- Mount support ring **22** and pretension ring **21**.
- ✓ The pretension ring rests against the support ring on the inside and the outside faces away from the support ring.

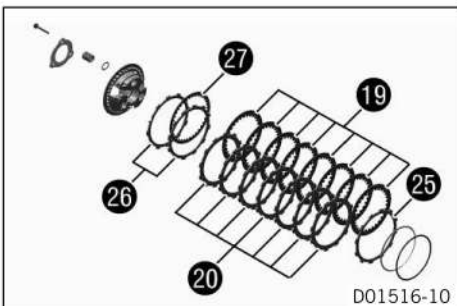

- Thoroughly oil the clutch facing discs.
- Mount a clutch facing disc **25** with a larger inside diameter.
- Alternately mount 8 intermediate clutch discs **19** and 7 of the same clutch facing discs **20**.
- Alternately mount 2 clutch facing discs **26** and an intermediate clutch disc **27** with a larger inside diameter.
- The outer clutch facing disc must be mounted offset by one mesh.

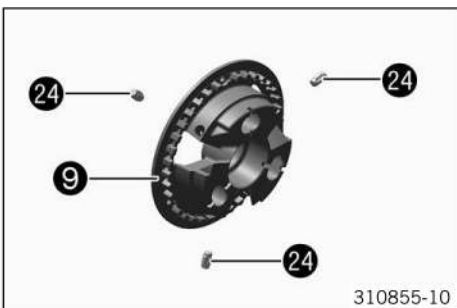

- Mount damper **24** in the clutch pressure cap **9**.

**i** Info

When changing the clutch discs, always renew the damper.

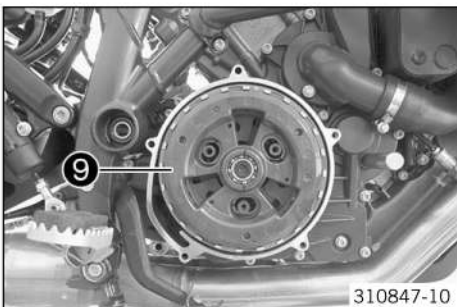

- Position clutch pressure cap **9**.
- ✓ The teeth of the outer intermediate clutch disc engages in the clutch pressure cap.
- ✓ The clutch pressure cap rests flush against the outer lining disc.

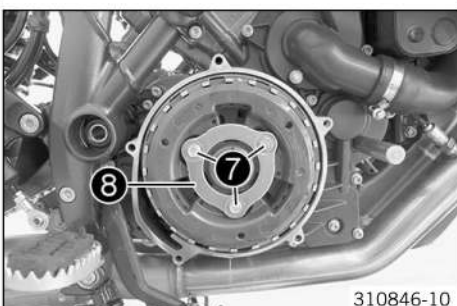

- Position clutch center **8** and the springs.
- Mount and tighten screws **7**.

Guideline

Screw, clutch spring	M6	12 Nm (8.9 lbf ft)
----------------------	----	--------------------

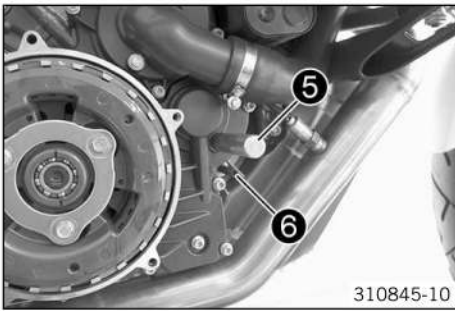

- Remove special tool 5.

Spread transmission locking pin (61329033000) (p. 352)
--

- Remove special tool 6.

Engine blocking screw (61229015000) (p. 349)
--

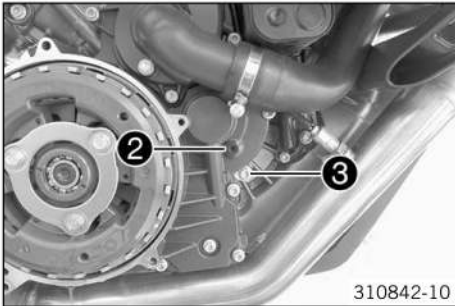

- Mount and tighten screw 2.

Guideline

Screw plug		10 Nm (7.4 lbf ft)
------------	--	--------------------

- Mount and tighten screw 3 with the washer.

Guideline

Plug, crankshaft retainer	M8	15 Nm (11.1 lbf ft)
---------------------------	----	------------------------



- Mount and tighten screw 4.

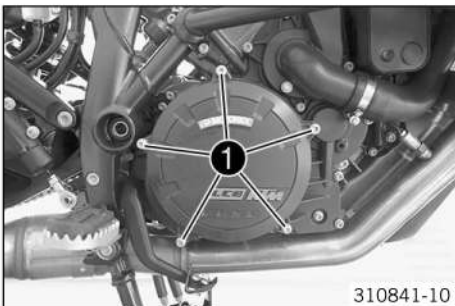

- Mount screws 1 and tighten in a crisscross pattern.

Guideline

Screw, clutch cover	M6	10 Nm (7.4 lbf ft)
---------------------	----	--------------------

- Take off outer clutch cover.

### Finishing work

- Check the engine oil level. (p. 276)

## 21.1 Checking the basic position of the shift lever

**i Info**

When driving, the shift lever must not touch the driver's boot when in the basic position. When the shift lever keeps touching the boot, the transmission will be subject to an excessive load.

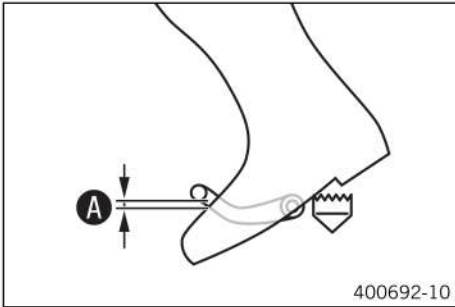

- Sit on the vehicle in the riding position and determine distance **A** between the upper edge of your boot and the shift lever.

Distance between shift lever and upper edge of boot	10... 20 mm (0.39... 0.79 in)
---	-------------------------------

- » If the distance does not meet specifications:
  - Adjust the basic position of the shift lever. (p. 251)

## 21.2 Adjusting the basic position of the shift lever

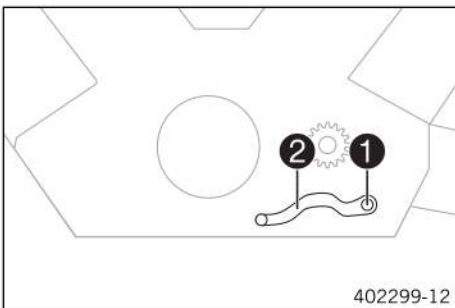

- Remove screw **1** and take off shift lever **2**.

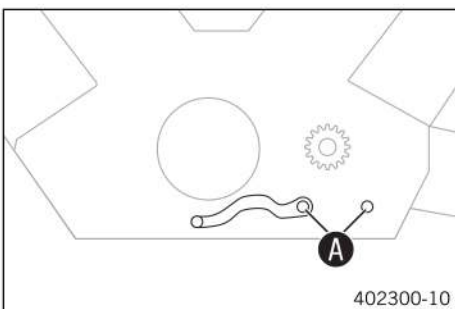

- Clean gear teeth **A** of the shift lever and shift shaft.
- Mount the shift lever on the shift shaft in the required position and engage the gearing.

**i Info**

The range of adjustment is limited. The shift lever must not come into contact with any other vehicle components during the shift procedure.

- Mount and tighten screw.

Guideline

Screw, shift lever	M6	18 Nm (13.3 lbf ft)	Loctite® 243™
--------------------	----	------------------------	---------------

## 21.3 Changing the gear position sensor

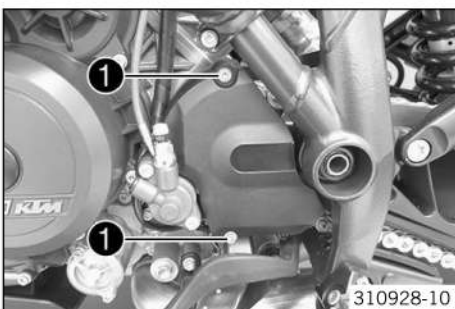

**Main work**

- Remove screws **1**.
- Take off the engine sprocket cover.

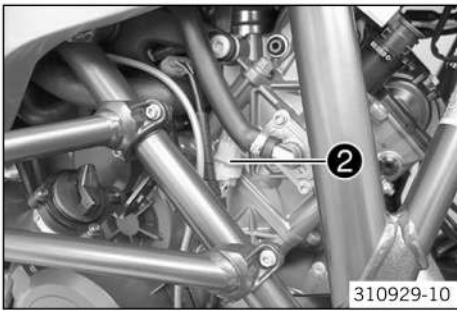

- Disconnect plug-in connector ②.
- Expose the cable.

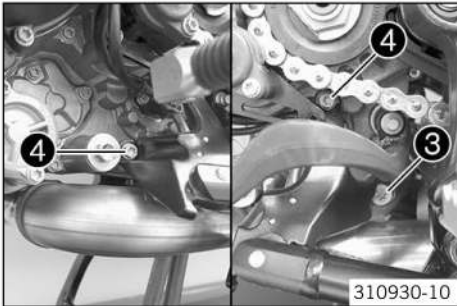

- Remove screw ③.
- Remove screws ④.
- Remove the side stand bracket and hang it to one side.



- Remove the cable tie(s).

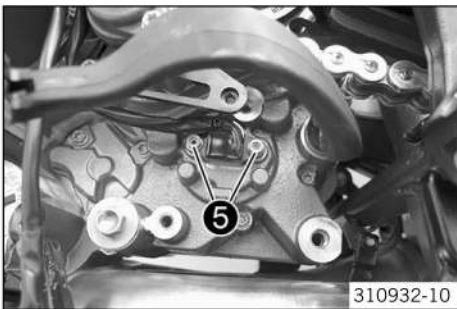

- Remove screws ⑤ with the washers.
- Remove the gear position sensor.
- Position the new gear position sensor.
- Mount and tighten screws ⑤ with the washers.

Guideline

Screw, gear sensor	M5	6 Nm (4.4 lbf ft)	Loctite® 243™
--------------------	----	----------------------	---------------



- Mount the cable tie(s).

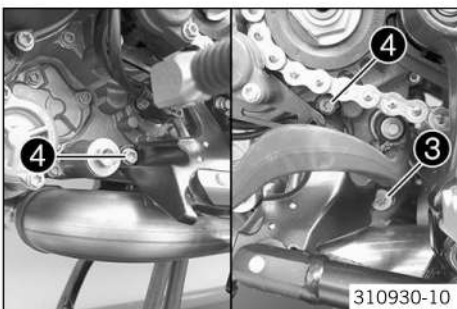

- Position the side stand bracket.
- Mount screw ③ but do not tighten yet.

Guideline

Screw, side stand bracket	M10	45 Nm (33.2 lbf ft)	Loctite® 243™
---------------------------	-----	------------------------	---------------

- Mount and tighten screws ④.

Guideline

Screw, side stand bracket	M8	25 Nm (18.4 lbf ft)	
---------------------------	----	------------------------	--

- Tighten screw ③.

Guideline

Screw, side stand bracket	M10	45 Nm (33.2 lbf ft)	Loctite® 243™
---------------------------	-----	------------------------	---------------

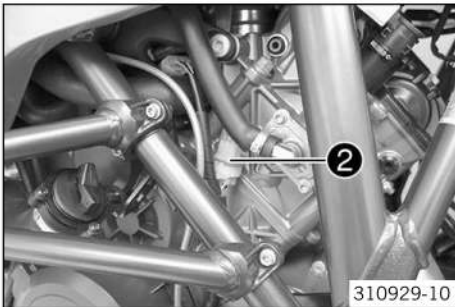

- Connect plug-in connector ②.
- Route the cable so it is not under tension and secure with a cable binder and a cable guard.

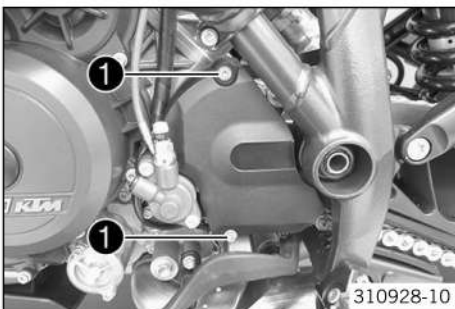

- Position the engine sprocket cover.
- Mount and tighten screws ①.

Guideline

Remaining chassis screws	M6	10 Nm (7.4 lbf ft)
--------------------------	----	--------------------

### Finishing work

- Program the gear position sensor. (📖 p. 253)

## 21.4 Programming gear position sensor

### Condition

The diagnostic tool is connected and running.

- Execute **"Engine electronics" > "Functions" > "Program gear position sensor"**.
- Switch off the ignition and switch it on again.
- ✓ The green idling speed indicator lamp **N** lights up.



## 22.1 Checking the coolant level in the compensating tank

**Warning**

**Danger of scalding** During motorcycle operation, the coolant gets very hot and is under pressure.

- Do not open the radiator, the radiator hoses or other cooling system components if the engine or the cooling system are at operating temperature.
- Allow the cooling system and the engine to cool down before you open the radiator, the radiator hoses or other components of the cooling system.
- In the event of scalding, rinse the area affected immediately with lukewarm water.

**Warning**

**Danger of poisoning** Coolant is toxic and a health hazard.

- Keep coolant out of the reach of children.
- Do not allow coolant to come into contact with the skin, the eyes and clothing.
- Consult a doctor immediately if coolant is swallowed.
- Rinse the affected area immediately with plenty of water in the event of contact with the skin.
- Rinse eyes thoroughly with water and consult a doctor immediately if coolant gets into the eyes.
- Change clothing if coolant spills onto your clothing.



**Condition**

The engine is cold.  
The radiator is completely full.

- Park the motorcycle on a horizontal surface.
- Check the coolant level in the compensating tank ①.

The coolant level must be between **MIN** and **MAX**.

- » If there is no coolant in the compensating tank:
  - Check the cooling system for leaks.

**i Info**

Do not start up the motorcycle!

- Add coolant/bleed the cooling system. (📖 p. 257)
- » If the coolant in the compensating tank is not at the required level, but the tank is not empty:
  - Correct the coolant level in the compensating tank. (📖 p. 254)

## 22.2 Correcting the coolant level in the compensating tank

**Warning**

**Danger of scalding** During motorcycle operation, the coolant gets very hot and is under pressure.

- Do not open the radiator, the radiator hoses or other cooling system components if the engine or the cooling system are at operating temperature.
- Allow the cooling system and the engine to cool down before you open the radiator, the radiator hoses or other components of the cooling system.
- In the event of scalding, rinse the area affected immediately with lukewarm water.

**Warning**

**Danger of poisoning** Coolant is toxic and a health hazard.

- Keep coolant out of the reach of children.
- Do not allow coolant to come into contact with the skin, the eyes and clothing.
- Consult a doctor immediately if coolant is swallowed.
- Rinse the affected area immediately with plenty of water in the event of contact with the skin.
- Rinse eyes thoroughly with water and consult a doctor immediately if coolant gets into the eyes.
- Change clothing if coolant spills onto your clothing.

**Condition**

The engine is cold.  
The radiator is completely full.



### Preparatory work

- Check the coolant level in the compensating tank. (📖 p. 254)
- Remove the crash bar. (📖 p. 32)
- Remove the front side cover. (📖 p. 87)



### Info

Only disassemble the right-hand side.



### Main work

- Remove cover ① of the compensating tank.



- Add coolant until the coolant reaches the specified level.

### Guideline

The coolant level must be between **MIN** and **MAX**.

Coolant (📖 p. 338)

- Mount the cover of the compensating tank.

### Finishing work

- Install the front side cover. (📖 p. 87)
- Install the crash bar. (📖 p. 32)

## 22.3 Checking the coolant fill level and antifreeze



### Warning

**Danger of scalding** During motorcycle operation, the coolant gets very hot and is under pressure.

- Do not open the radiator, the radiator hoses or other cooling system components if the engine or the cooling system are at operating temperature.
- Allow the cooling system and the engine to cool down before you open the radiator, the radiator hoses or other components of the cooling system.
- In the event of scalding, rinse the area affected immediately with lukewarm water.



### Warning

**Danger of poisoning** Coolant is toxic and a health hazard.

- Keep coolant out of the reach of children.
- Do not allow coolant to come into contact with the skin, the eyes and clothing.
- Consult a doctor immediately if coolant is swallowed.
- Rinse the affected area immediately with plenty of water in the event of contact with the skin.
- Rinse eyes thoroughly with water and consult a doctor immediately if coolant gets into the eyes.
- Change clothing if coolant spills onto your clothing.

### Condition

The engine is cold.

### Preparatory work

- Park the motorcycle on a horizontal surface.
- Raise the vehicle with the center stand. (📖 p. 12)
- Remove the passenger seat. (📖 p. 72)
- Remove the front rider's seat. (📖 p. 71)
- Remove the crash bar. (📖 p. 32)
- Remove the front side cover. (📖 p. 87)



- Remove the tank cover. (📖 p. 89)
- Remove the mask spoiler. (📖 p. 90)
- Remove the fuel tank. (📖 p. 73)

**Main work**

- Remove radiator cap ① and the cover of the compensating tank.
- Check the antifreeze in the coolant.

-25... -45 °C (-13... -49 °F)

- » If the antifreeze in the coolant does not equal the specified value:
  - Correct the antifreeze in the coolant.

- Check the coolant level.

The radiator must be filled completely.

The coolant level in the compensating tank must be between **MIN** and **MAX**.

- » If the coolant level does not equal the specified value:
  - Check the coolant level and the reason for the loss.

- Mount the radiator cap and the cover of the compensating tank.

**Finishing work**

- Install the fuel tank. (📖 p. 74)
- Install the mask spoiler. (📖 p. 92)
- Install the tank cover. (📖 p. 89)
- Install the front side cover. (📖 p. 87)
- Install the crash bar. (📖 p. 32)
- Mount the front rider's seat. (📖 p. 71)
- Mount the passenger seat. (📖 p. 72)
- Remove the vehicle from the center stand. (📖 p. 12)

## 22.4 Draining the coolant



**Warning**

**Danger of scalding** During motorcycle operation, the coolant gets very hot and is under pressure.

- Do not open the radiator, the radiator hoses or other cooling system components if the engine or the cooling system are at operating temperature.
- Allow the cooling system and the engine to cool down before you open the radiator, the radiator hoses or other components of the cooling system.
- In the event of scalding, rinse the area affected immediately with lukewarm water.



**Warning**

**Danger of poisoning** Coolant is toxic and a health hazard.

- Keep coolant out of the reach of children.
- Do not allow coolant to come into contact with the skin, the eyes and clothing.
- Consult a doctor immediately if coolant is swallowed.
- Rinse the affected area immediately with plenty of water in the event of contact with the skin.
- Rinse eyes thoroughly with water and consult a doctor immediately if coolant gets into the eyes.
- Change clothing if coolant spills onto your clothing.

**Condition**

The engine is cold.

**Preparatory work**

- Raise the vehicle with the center stand. (📖 p. 12)
- Remove the passenger seat. (📖 p. 72)
- Remove the front rider's seat. (📖 p. 71)
- Remove the crash bar. (📖 p. 32)
- Remove the front side cover. (📖 p. 87)
- Remove the tank cover. (📖 p. 89)
- Remove the mask spoiler. (📖 p. 90)
- Remove the fuel tank. (📖 p. 73)

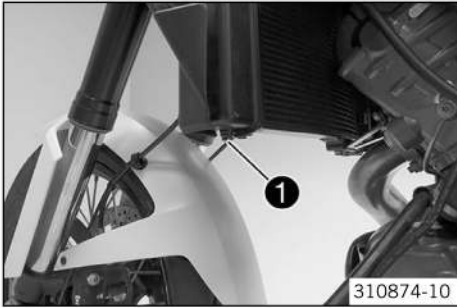

**Main work**

- Place a suitable container under the radiator.
- Remove screw ❶.
- Remove radiator cap.
- Completely drain the coolant.
- Mount screw ❶ with a new seal ring and tighten it.

**Guideline**

Remaining chassis screws	M6	10 Nm (7.4 lbf ft)
--------------------------	----	--------------------

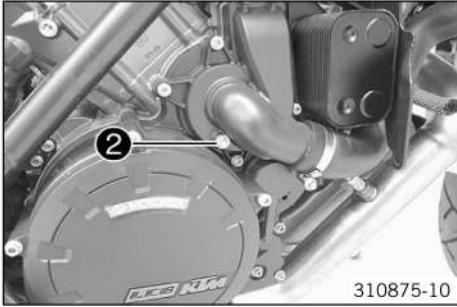

- Place a suitable container under the engine.
- Remove screw ❷.
- Completely drain the coolant.
- Mount screw ❷ with a new seal ring and tighten it.

**Guideline**

Screw, water pump cover	M6	10 Nm (7.4 lbf ft)
-------------------------	----	--------------------

## 22.5 Adding coolant/bleeding the cooling system



**Warning**

**Danger of poisoning** Coolant is toxic and a health hazard.

- Keep coolant out of the reach of children.
- Do not allow coolant to come into contact with the skin, the eyes and clothing.
- Consult a doctor immediately if coolant is swallowed.
- Rinse the affected area immediately with plenty of water in the event of contact with the skin.
- Rinse eyes thoroughly with water and consult a doctor immediately if coolant gets into the eyes.
- Change clothing if coolant spills onto your clothing.

**Condition**

The fuel tank is removed.

- Position the vehicle as shown and secure it against rolling. Height difference **A** must be reached.

**Guideline**

Height difference <b>A</b>	50 cm (19.7 in)
----------------------------	-----------------

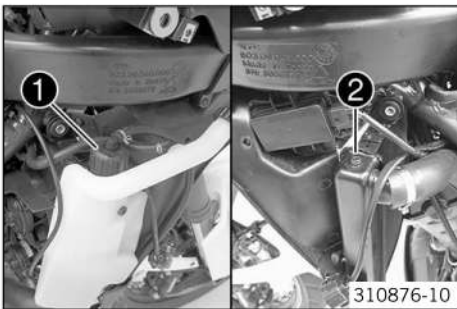
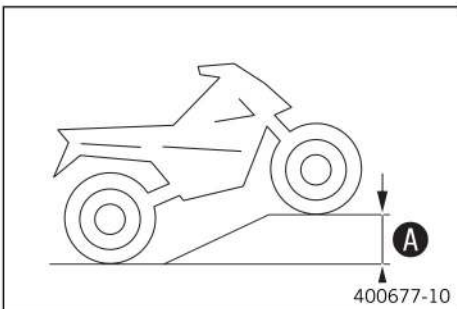

- Remove radiator cap ❶ and bleeder screw ❷ of the radiator.

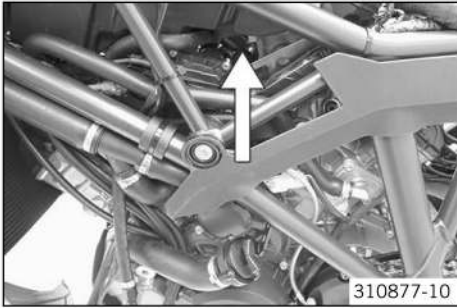

- Lift up the heat protector.

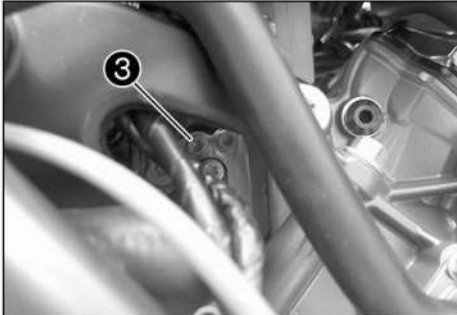

- Remove bleeder screws ③ of the cylinder heads.
- Add coolant until it exits from the vent hole without bubbles.

Coolant	2.40 l (2.54 qt.)	Coolant (📖 p. 338)
---------	-------------------	--------------------

- Mount and tighten the bleeder screws with the seal rings.

Guideline

Remaining engine screws	M6	10 Nm (7.4 lbf ft)
Remaining chassis screws	M6	10 Nm (7.4 lbf ft)

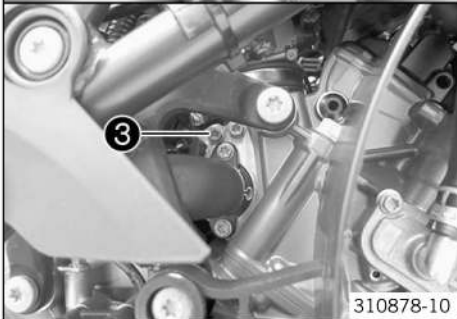

- Position the heat protectors.



- Completely fill the radiator with coolant and close it with radiator cap ①.
- Position the vehicle on a level surface.
- Remove the cover of the compensating tank.
- Add coolant to the compensating tank until the coolant reaches the specified level.

Guideline

The coolant level must be between <b>MIN</b> and <b>MAX</b> .
---

- Mount the cover of the compensating tank.

## 23.1 Checking the valve clearance

### Condition

The air filter is removed.

- Remove spring band clamp **1**.

Pliers for spring band clamp (60029057100) (p. 347)

- Pull off the air release hose.

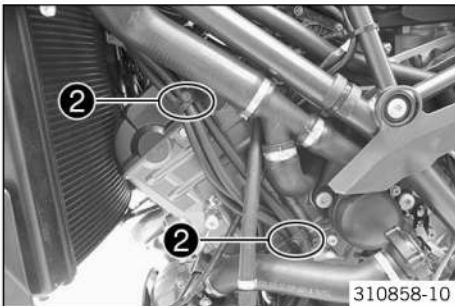
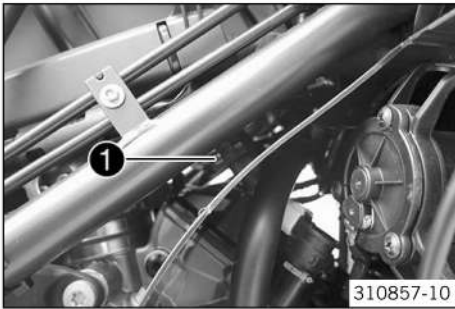

- Remove cable tie(s) **2**.



- Remove screws **3**.
- Remove the intake trumpet.

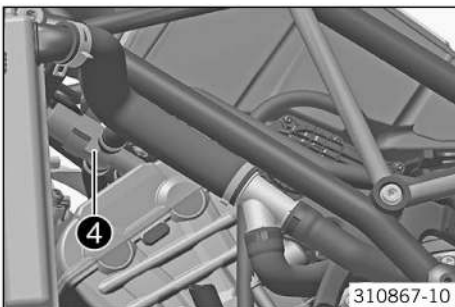

- Remove SAS valve **4** from the holder.

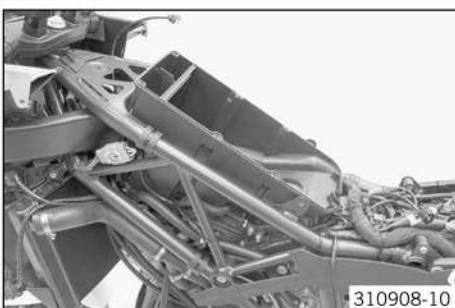

- Raise the lower part of the air filter box and pull it back gently.

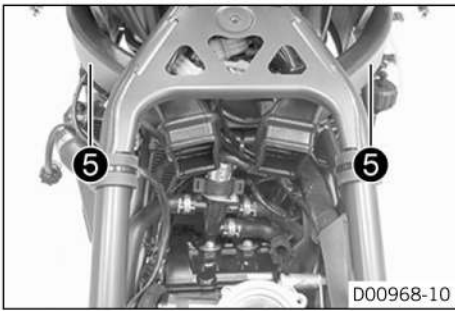

- Remove intake snorkel **5**.

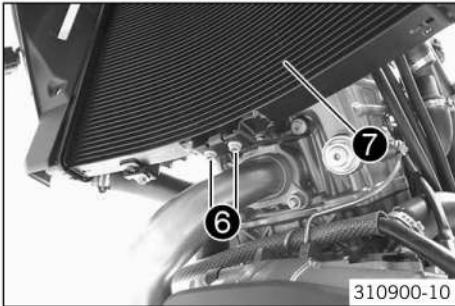

- Remove screws **6**.
- Swing the radiator **7** forward slightly.

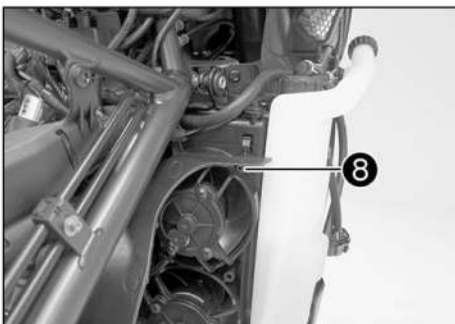

- Remove screw **8**.
- Pull heat protector off the holder from the front and remove protector.

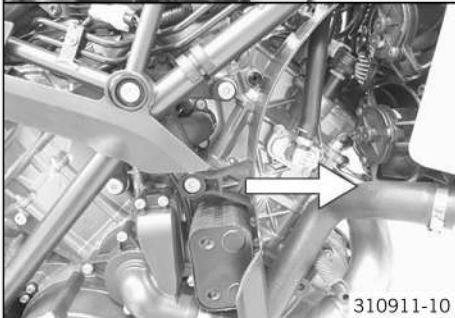

- Remove the cable tie(s).
- Disconnect plug-in connector **9**.
- Pull the SAS valve back and fix it into position.

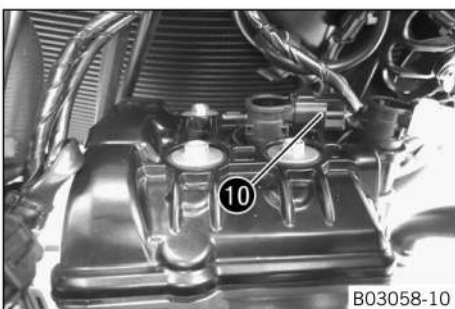

- Detach connector **10** of the ignition coil.
- Remove the ignition coil.

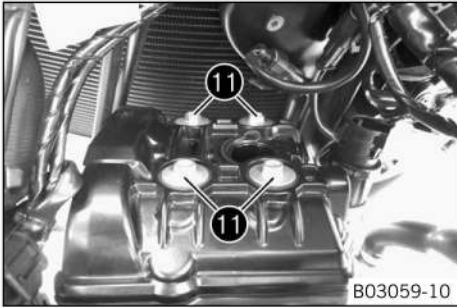

- Remove screws **11**.
- Remove the spark plug using the special tool.

Spark plug wrench (77229172000) (📖 p. 353)

- Remove the valve cover with the gasket.

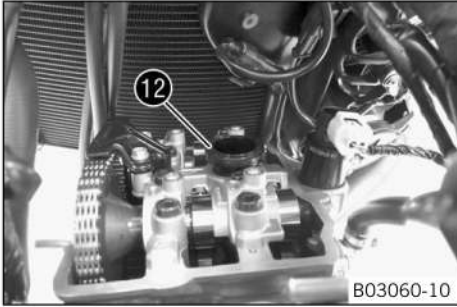

- Remove gasket **12**.

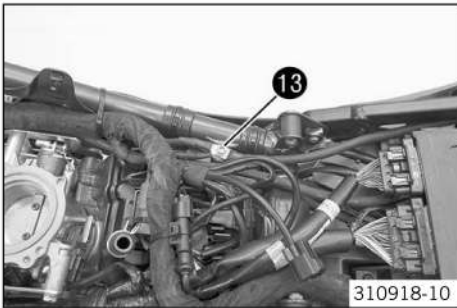

- Remove screw **13** with the washer.

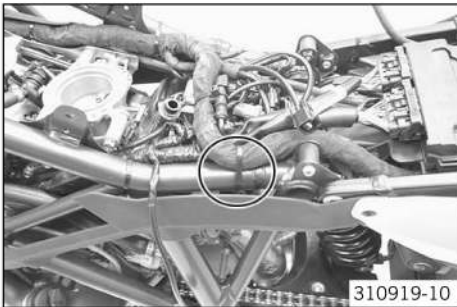

- Remove the cable tie(s).
- Push the cables slightly to the side.

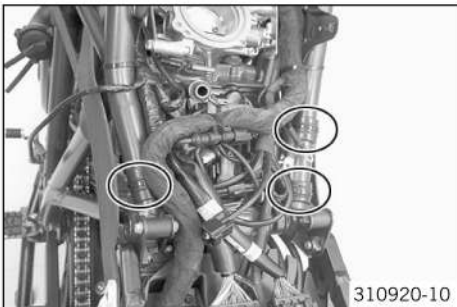

- Remove the cable tie(s).

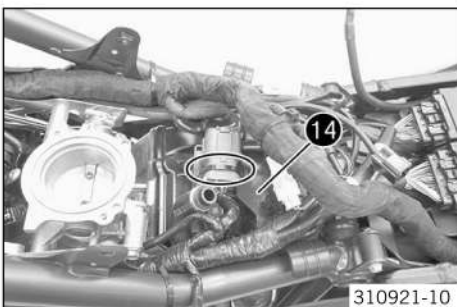

- Remove the cable tie(s).
- Loosen old connector from connector holder **14**.
- Remove the plug holder.

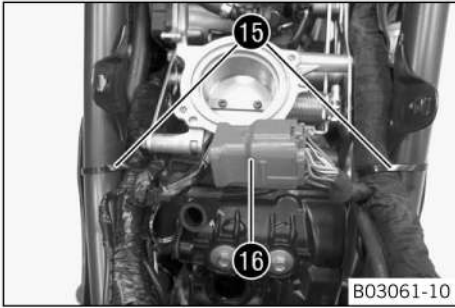

- Remove cable tie(s) 15.
- Disconnect plug-in connector 16.

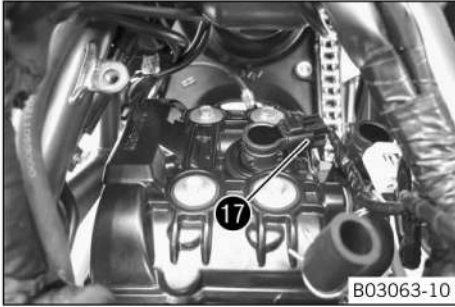

- Detach connector 17 of the ignition coil.
- Remove the ignition coil.
- Remove the spark plug using the special tool.

Spark plug wrench (77229172000) (📖 p. 353)

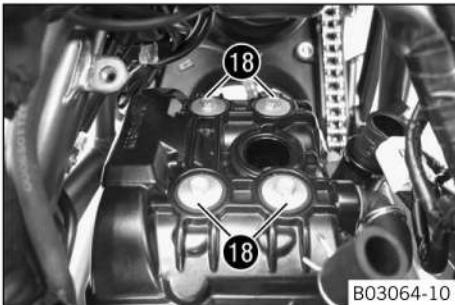

- Remove screws 18.
- Remove the valve cover with the gasket.

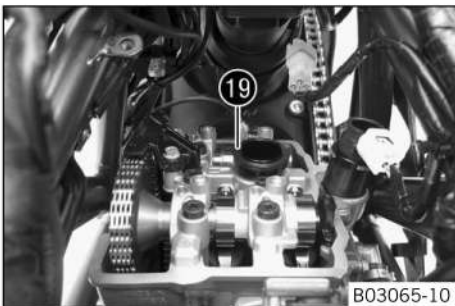

- Remove gasket 19.
- Set the engine to ignition top dead center of the rear cylinder. (📖 p. 169)

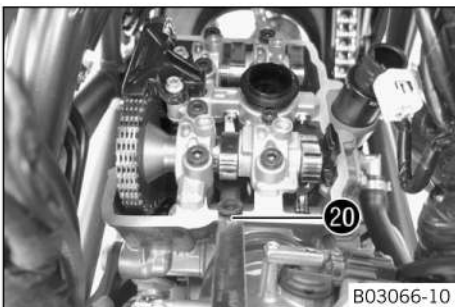

- On all valves, check the valve clearance between the camshaft and cam lever with special tool 20.

**Guideline**

Valve clearance	
Exhaust at: 20 °C (68 °F)	0.25... 0.30 mm (0.0098... 0.0118 in)
Intake at: 20 °C (68 °F)	0.10... 0.15 mm (0.0039... 0.0059 in)

Feeler gauge (59029041100) (📖 p. 346)

- » If the valve clearance does not meet specifications:
  - Set the valve clearance of the rear cylinder. (📖 p. 270)
- Set the engine to ignition top dead center of the front cylinder. (📖 p. 169)



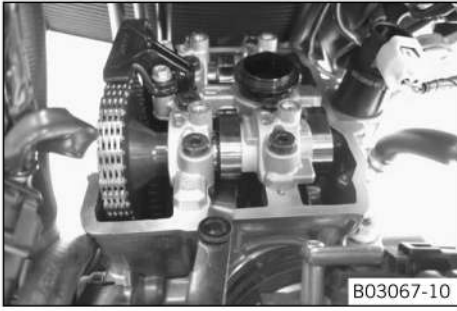

- On all valves, check the valve clearance between the camshaft and cam lever with the special tool.

Guideline

Valve clearance	
Exhaust at: 20 °C (68 °F)	0.25... 0.30 mm (0.0098... 0.0118 in)
Intake at: 20 °C (68 °F)	0.10... 0.15 mm (0.0039... 0.0059 in)

Feeler gauge (59029041100) (🔧 p. 346)

- » If the valve clearance does not meet specifications:
  - Set the valve clearance of the front cylinder. (🔧 p. 271)

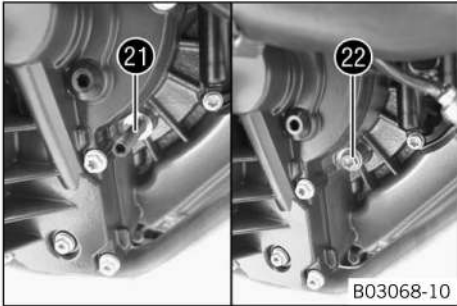

- Remove special tool 21.
- Crank the engine several times. Check the valve clearance and correct it if necessary.
- Remove special tool 21 and mount and tighten screw 22 with washer.

Guideline

Plug, crankshaft retainer	M8	15 Nm (11.1 lbf ft)
---------------------------	----	---------------------



- Mount and tighten screw 23 of the alternator cover.

Guideline

Screw in alternator cover	M24x1.5	8 Nm (5.9 lbf ft)
---------------------------	---------	-------------------

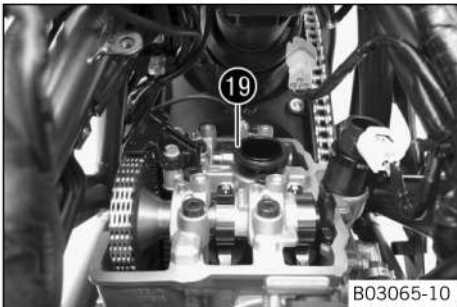

- Mount gasket 19.

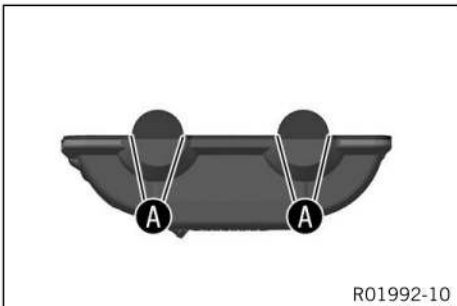

- Clean and degrease the valve cover seal.
- Apply a thin layer of sealant to area A.

Loctite® 5910

**i Info**

The rear valve cover is equipped with a connector for the engine vent.  
The front valve cover is not equipped with a connector for the engine vent.

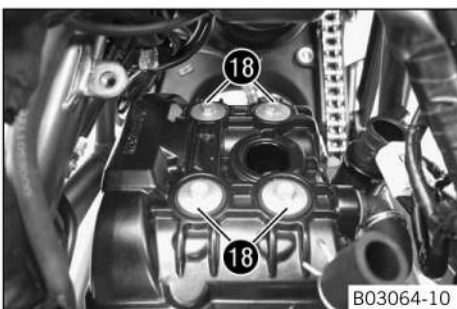

- Put the valve cover in place with the gasket. Mount and tighten screws 18.

Guideline

Screw, valve cover	M6	10 Nm (7.4 lbf ft)
--------------------	----	--------------------

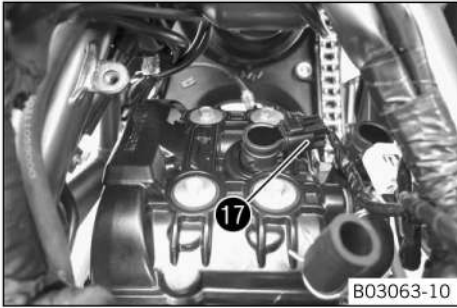

- Mount and tighten the spark plug using the special tool.

Spark plug wrench (75029172000) (📖 p. 353)

- Mount the ignition coil.
- Attach connector 17 of the ignition coil.
- ✓ The cable with the white marking is connected to the outer ignition coil.

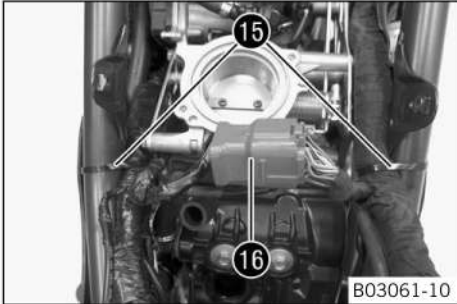

- Join plug-in connector 16.
- Mount cable tie(s) 15.

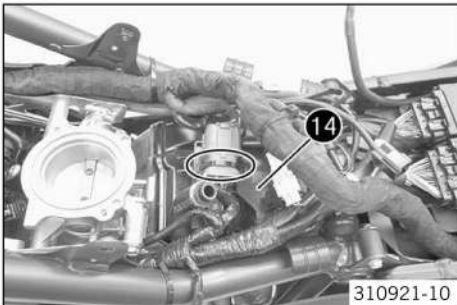

- Position the plug holder.
- Connect all connectors in the connector holder 14.
- Mount the cable tie(s).

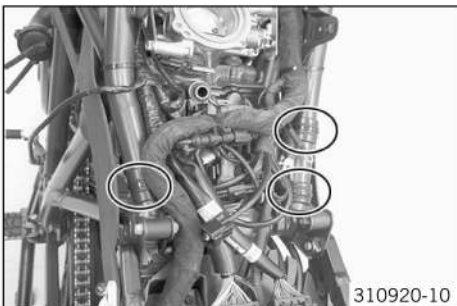

- Mount the cable tie(s).

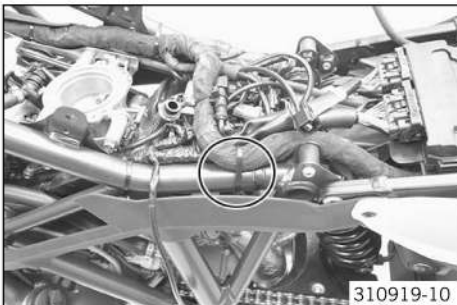

- Route the cable without tension.
- Mount the cable tie(s).

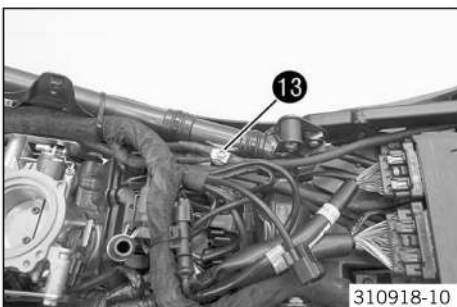

- Mount and tighten screw 13 with the washer.

Guideline

Remaining chassis screws	M6	10 Nm (7.4 lbf ft)
--------------------------	----	--------------------

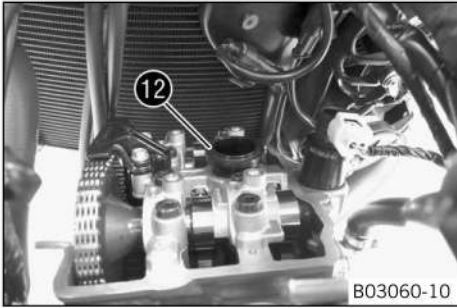

B03060-10

- Position gasket **12**.

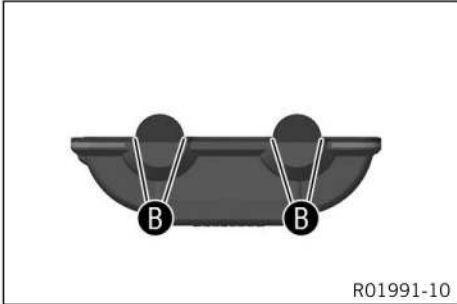

R01991-10

- Clean and degrease the valve cover seal.
- Apply a thin layer of sealant to area **B**.

**Loctite® 5910**



**Info**

The rear valve cover is equipped with a connector for the engine vent.  
The front valve cover is not equipped with a connector for the engine vent.

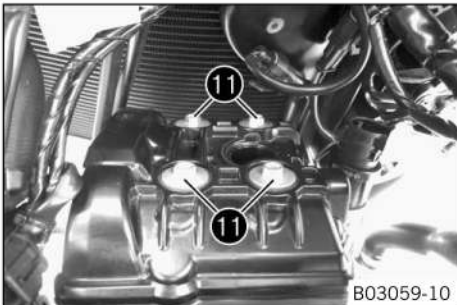

B03059-10

- Mount the valve cover with the gasket.
- Mount and tighten screws **11**.

**Guideline**

Screw, valve cover	M6	10 Nm (7.4 lbf ft)
--------------------	----	--------------------

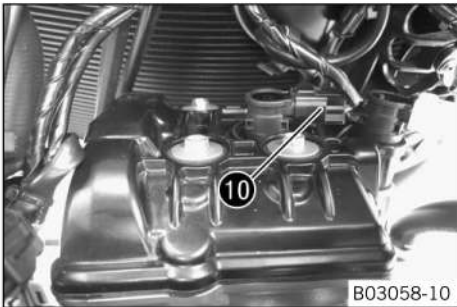

B03058-10

- Mount and tighten the spark plug using the special tool.

Spark plug wrench (75029172000) (📖 p. 353)

- Mount the ignition coil.
- Attach connector **10** of the ignition coil.
- ✓ The cable with the white marking is connected to the outer ignition coil.



310912-10

- Position SAS valve.
- Join plug-in connector **9**.
- Mount the cable tie(s).



- Position the heat protector and mount to holder.
- Mount and tighten screw **8**.

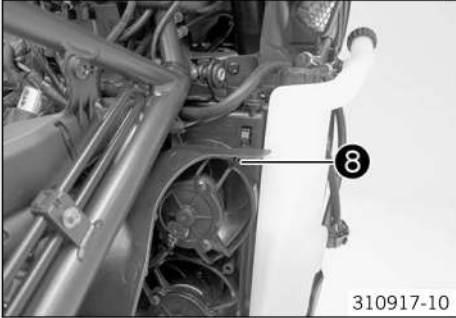

310917-10

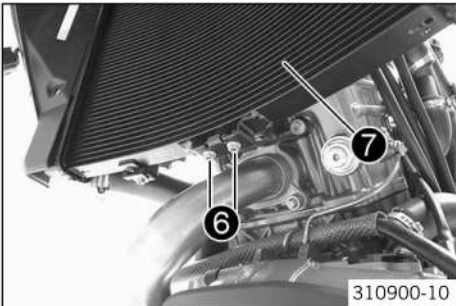

- Position the radiator **7**.
- Mount and tighten screws **6**.

Guideline

Remaining screws, chassis	M5	5 Nm (3.7 lbf ft)
---------------------------	----	-------------------

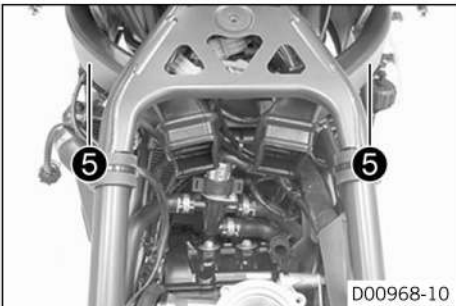

- Mount intake snorkel **5**.

D00968-10

**i** Info

Ensure that the seals are seated correctly.

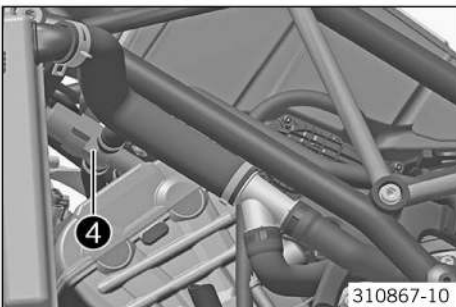

- Mount SAS valve **4** on the holder.

310867-10



- Position the lower part of the air filter box in the frame.

**i** Info

Ensure that the O-rings are seated correctly.

310908-10



- Position the intake trumpet and mount and tighten screws ③ with the bushing.

Guideline

Remaining screws, chassis	M5	5 Nm (3.7 lbf ft)
---------------------------	----	-------------------

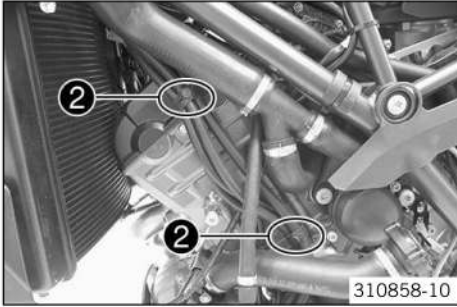

- Route the hose without kinks.
- Mount cable tie(s) ②.

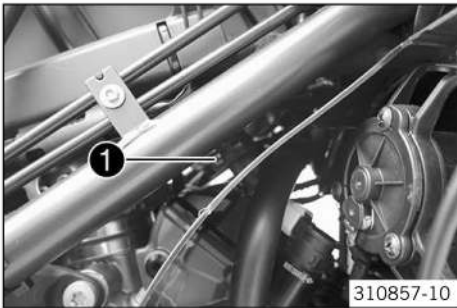

- Mount the vent hose.
- Position spring band clamp ① with special tool.

Pliers for spring band clamp (60029057100) (p. 347)

## 23.2 Checking the valve clearance (air filter and spark plugs removed)

### Condition

The air filter and spark plugs are removed.

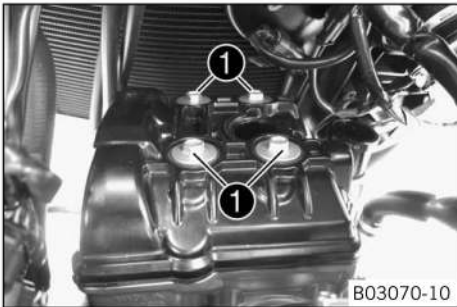

- Remove screws ①.
- Remove the valve cover with the gasket.

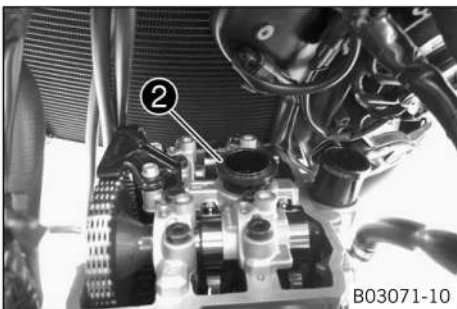

- Remove gasket ②.

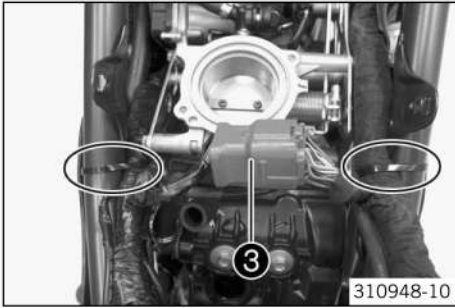

- Remove the cable tie(s).
- Disconnect plug-in connector ③.

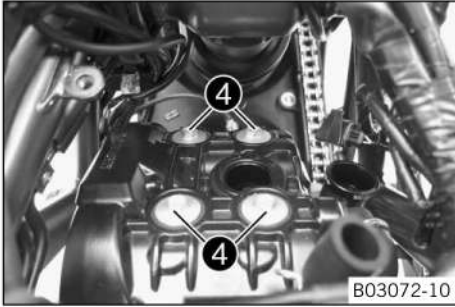

- Remove screws ④.
- Remove the valve cover with the gasket.

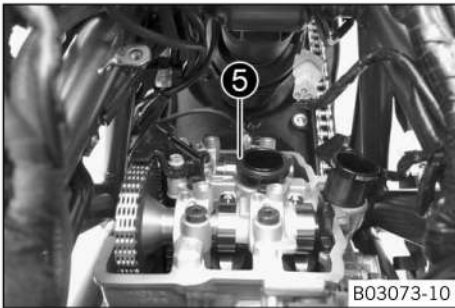

- Remove gasket ⑤.
- Set the engine to ignition top dead center of the rear cylinder. (📖 p. 169)

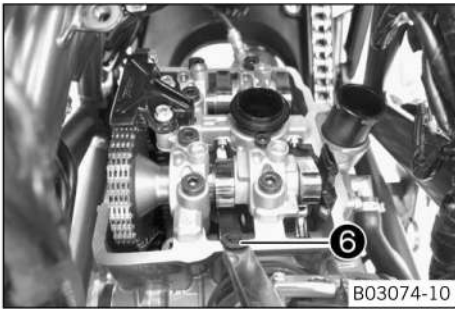

- On all valves, check the valve clearance between the camshaft and cam lever with special tool ⑥.

Guideline

Valve clearance	
Exhaust at: 20 °C (68 °F)	0.25... 0.30 mm (0.0098... 0.0118 in)
Intake at: 20 °C (68 °F)	0.10... 0.15 mm (0.0039... 0.0059 in)

Feeler gauge (59029041100) (📖 p. 346)

- » If the valve clearance does not meet specifications:
  - Set the valve clearance of the rear cylinder. (📖 p. 270)

- Set the engine to ignition top dead center of the front cylinder. (📖 p. 169)

- On all valves, check the valve clearance between the camshaft and cam lever with the special tool.

Guideline

Valve clearance	
Exhaust at: 20 °C (68 °F)	0.25... 0.30 mm (0.0098... 0.0118 in)
Intake at: 20 °C (68 °F)	0.10... 0.15 mm (0.0039... 0.0059 in)

Feeler gauge (59029041100) (📖 p. 346)

- » If the valve clearance does not meet specifications:
  - Set the valve clearance of the front cylinder. (📖 p. 271)

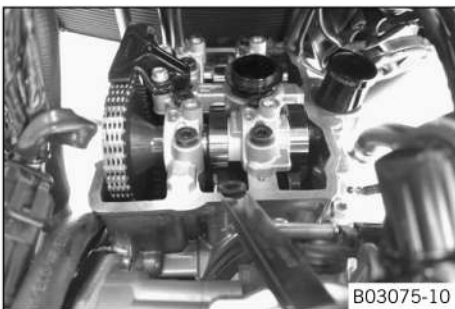

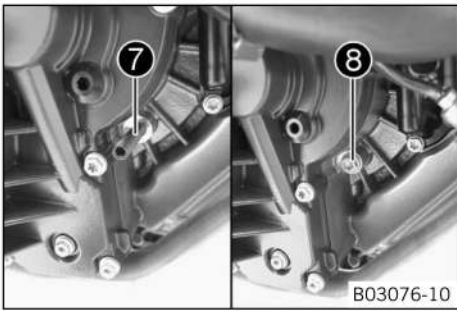

- Remove special tool 7.
- Crank the engine several times. Check the valve clearance and correct it if necessary.
- Remove special tool 7 and mount and tighten screw 8 with washer.

Guideline

Plug, crankshaft retainer	M8	15 Nm (11.1 lbf ft)
---------------------------	----	------------------------



- Mount and tighten screw 9 of the alternator cover.

Guideline

Screw in alternator cover	M24x1.5	8 Nm (5.9 lbf ft)
---------------------------	---------	-------------------

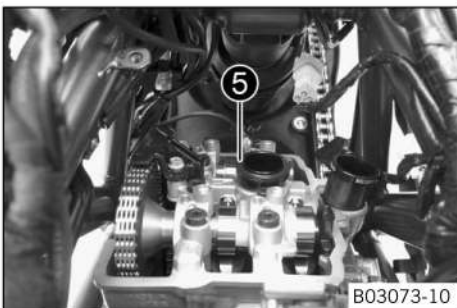

- Mount gasket 5.

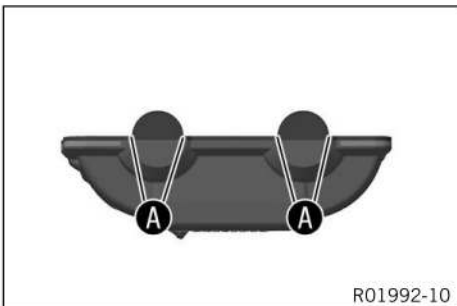

- Clean and degrease the valve cover seal.
- Apply a thin layer of sealant to area A.

Loctite® 5910



**Info**

The rear valve cover is equipped with a connector for the engine vent.  
The front valve cover is not equipped with a connector for the engine vent.

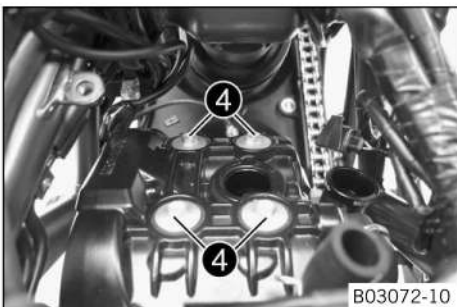

- Put the valve cover in place with the gasket. Mount and tighten screws 4.

Guideline

Screw, valve cover	M6	10 Nm (7.4 lbf ft)
--------------------	----	--------------------

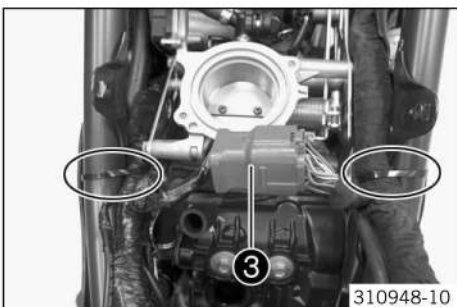

- Join plug-in connector 3.
- Mount the cable tie(s).

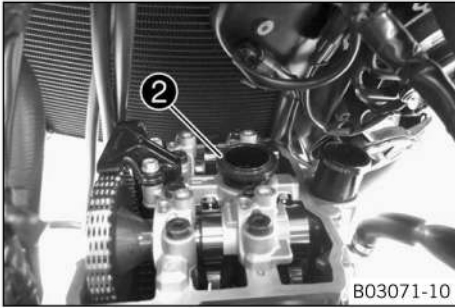

- Position gasket ②.

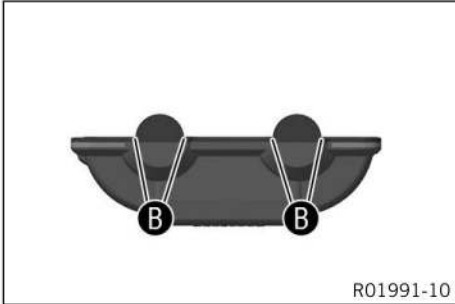

- Clean and degrease the valve cover seal.
- Apply a thin layer of sealant to area ⑥.

Loctite® 5910

**i Info**

The rear valve cover is equipped with a connector for the engine vent. The front valve cover is not equipped with a connector for the engine vent.

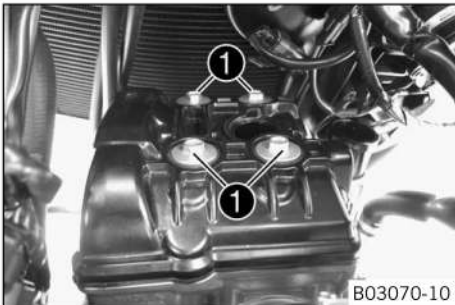

- Mount the valve cover with the gasket.
- Mount and tighten screws ①.

Guideline

Screw, valve cover	M6	10 Nm (7.4 lbf ft)
--------------------	----	--------------------

## 23.3 Setting the valve clearance of the rear cylinder

**i Info**

For purposes of illustration, the following operations are shown with the engine deinstalled. Removal is not necessary.

**Condition**

The engine is positioned at ignition top dead center of the rear cylinder

**Preparatory work**

- Disassemble the camshafts of the rear cylinder. (p. 271)

**Main work**

- Lift cam lever ①.
- Remove shims ② and set them down according to the installation position.
- Correct and insert the shims as indicated by the results of the valve clearance check.

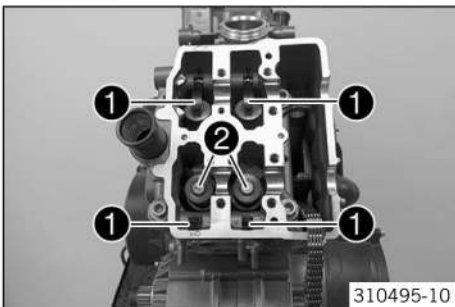

**Finishing work**

- Install the camshafts of the rear cylinder. (p. 272)



## 23.4 Setting the valve clearance of the front cylinder

**i** **Info**

For purposes of illustration, the following operations are shown with the engine deinstalled. Removal is not necessary.

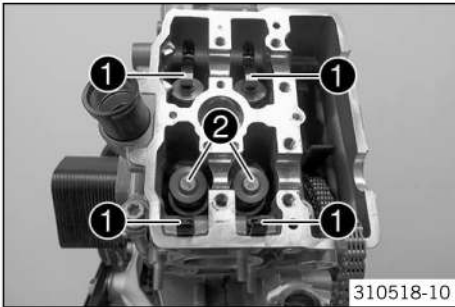

**Condition**

The engine is positioned at ignition top dead center of the front cylinder

**Preparatory work**

- Disassemble the camshafts of the front cylinder. (📖 p. 273)

**Main work**

- Lift cam lever **1**.
- Remove shims **2** and set them down according to the installation position.
- Correct and insert the shims as indicated by the results of the valve clearance check.

**Finishing work**

- Install the camshafts of the front cylinder. (📖 p. 273)

## 23.5 Disassembling the camshafts of the rear cylinder

**Condition**

The engine is positioned at ignition top dead center of the rear cylinder

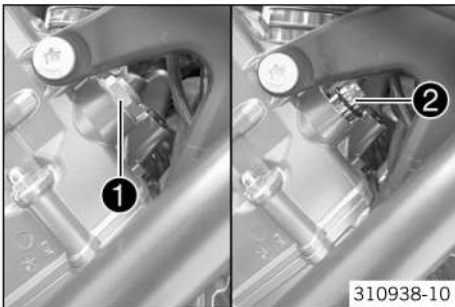

- Remove screw **1** with the O-ring.
- Pull out timing chain tensioner **2**.

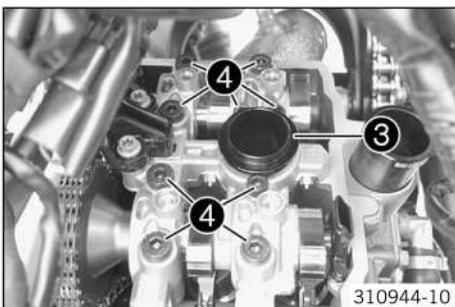

- Remove spark plug shaft insert **3**.
- Loosen and remove screws **4** from the outside to the inside.

**i** **Info**

The cams should not activate the valves.

- Remove the camshaft bearing bridge.
- Remove the timing chain from the rear sprocket. Remove the camshafts.

## 23.6 Installing the camshafts of the rear cylinder

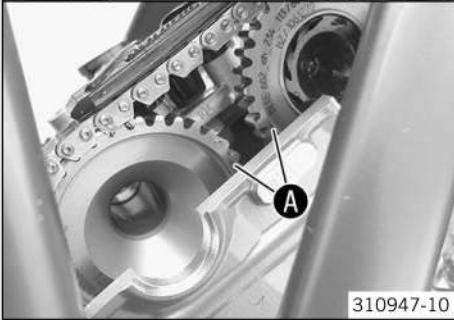
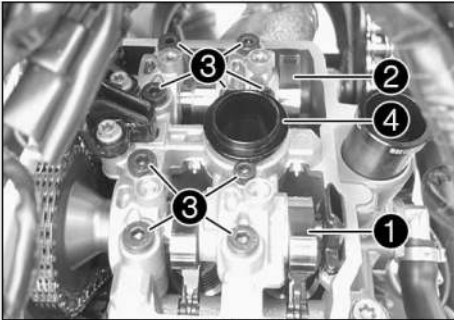

- Pull up the timing chain and insert intake camshaft **1**.



**Info**

The intake camshaft is labeled with **eh**.

- Place the timing chain over the rear sprocket of the intake camshaft.
- Ensure that bleeder is seated correctly.
- Position exhaust camshaft **2**.



**Info**

The exhaust camshaft is labeled with **ah**.

- Place the timing chain over the rear sprocket and position the camshaft in the bearing seat.
- ✓ Markings **A** must be flush with the edge of the cylinder head.
- Position the camshaft bearing bridge.
- Mount screws **3** and tighten them from the inside to the outside.

Guideline

Screw, camshaft bearing support	M6 – 10.9	10 Nm (7.4 lbf ft)	–
Screw, camshaft bearing support	M8 – 10.9	Step 1 10 Nm (7.4 lbf ft) Step 2 18 Nm (13.3 lbf ft)	–
Screw, camshaft bearing support	M8 – 10.9	Step 1 8.5 Nm (6.27 lbf ft) Step 2 14.5 Nm (10.7 lbf ft)	Only applies when using: Hex key bit (61229025000) (p. 350)

Hex key bit (61229025000) (p. 350)

- Grease the O-rings and mount spark plug shaft insert **4**.
- Prepare the timing chain tensioner for installation. (p. 206)
- After it has been positioned in the installation location, insert timing chain tensioner **5** with a new O-ring.
- Mount and tighten screw plug **6** with a new seal ring.

Guideline

Plug, timing-chain tensioner	M24x1.5	25 Nm (18.4 lbf ft)
------------------------------	---------	---------------------

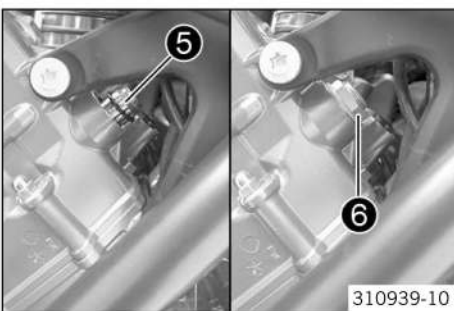

- Remove screw **7** and use the special tool to push the timing chain tensioner toward the timing chain.

Release device for timing chain tensioner (61229021000) (p. 350)

- ✓ The timing chain tensioner unlocks.

- Mount and tighten screw **7**.

Guideline

Screw, timing chain tensioner release	M10x1	10 Nm (7.4 lbf ft)
---------------------------------------	-------	--------------------

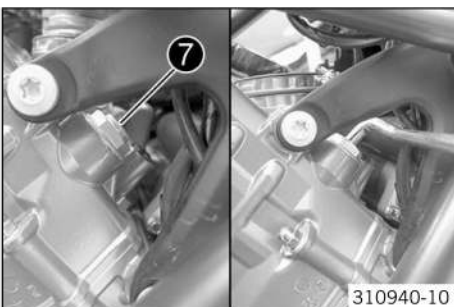

## 23.7 Disassembling the camshafts of the front cylinder

### Condition

The engine is positioned at ignition top dead center of the front cylinder

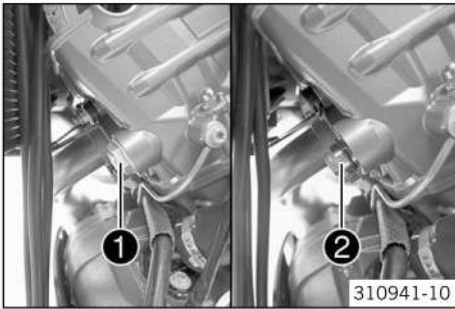

310941-10

- Remove screw **1** with the O-ring.
- Pull out timing chain tensioner **2**.

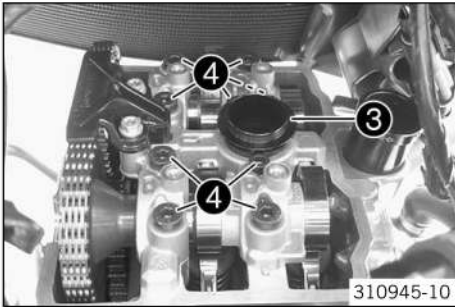

310945-10

- Remove spark plug shaft insert **3**.
- Loosen and remove screws **4** from the outside to the inside.

### **i** Info

The cams should not activate the valves.

- Remove the camshaft bearing bridge.
- Remove the timing chain from the rear sprocket. Remove the camshafts.

## 23.8 Installing the camshafts of the front cylinder

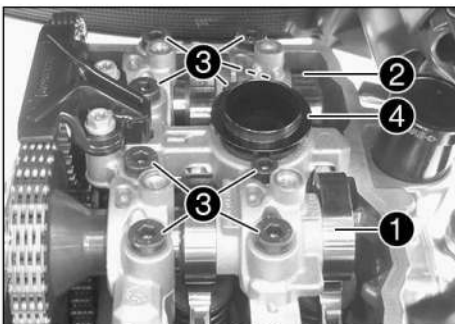

310946-10

- Pull up the timing chain and insert intake camshaft **1**.

### **i** Info

The intake camshaft is labeled with **ev**.

- Place the timing chain over the rear sprocket of the intake camshaft.
- Position exhaust camshaft **2**.

### **i** Info

The exhaust camshaft is labeled with **av**.

- Place the timing chain over the rear sprocket and position the camshaft in the bearing seat.
- ✓ Markings **A** must be flush with the edge of the cylinder head.
- Position the camshaft bearing bridge.
- Mount screws **3** and tighten them from the inside to the outside.

### Guideline

Screw, camshaft bearing support	M6 – 10.9	10 Nm (7.4 lbf ft)	–
Screw, camshaft bearing support	M8 – 10.9	Step 1 10 Nm (7.4 lbf ft) Step 2 18 Nm (13.3 lbf ft)	–
Screw, camshaft bearing support	M8 – 10.9	Step 1 8.5 Nm (6.27 lbf ft) Step 2 14.5 Nm (10.7 lbf ft)	Only applies when using: Hex key bit (61229025000) (p. 350)

Hex key bit (61229025000) (p. 350)

- Grease the O-rings and mount spark plug shaft insert **4**.
- Prepare the timing chain tensioner for installation. (p. 206)

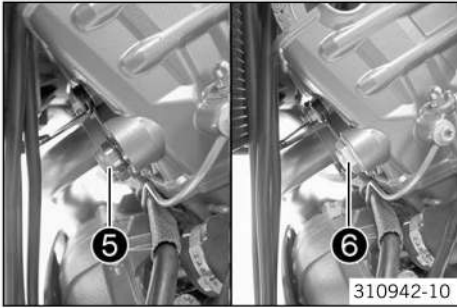

- After it has been positioned in the installation location, insert timing chain tensioner **5** with a new O-ring.
- Mount and tighten screw plug **6** with a new seal ring.

Guideline

Plug, timing-chain tensioner	M24x1.5	25 Nm (18.4 lbf ft)
------------------------------	---------	------------------------

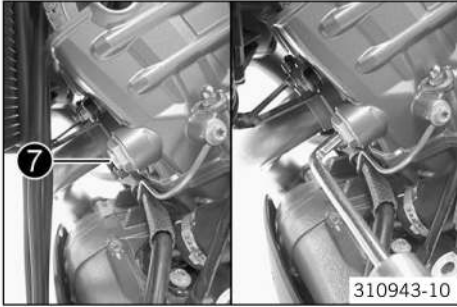

- Remove screw **7** and use the special tool to push the timing chain tensioner toward the timing chain.

Release device for timing chain tensioner (61229021000) (📄 p. 350)

✓ The timing chain tensioner is unlocked.

- Mount and tighten screw **7**.

Guideline

Screw, timing chain tensioner release	M10x1	10 Nm (7.4 lbf ft)
---------------------------------------	-------	--------------------

## 24.1 Oil circuit

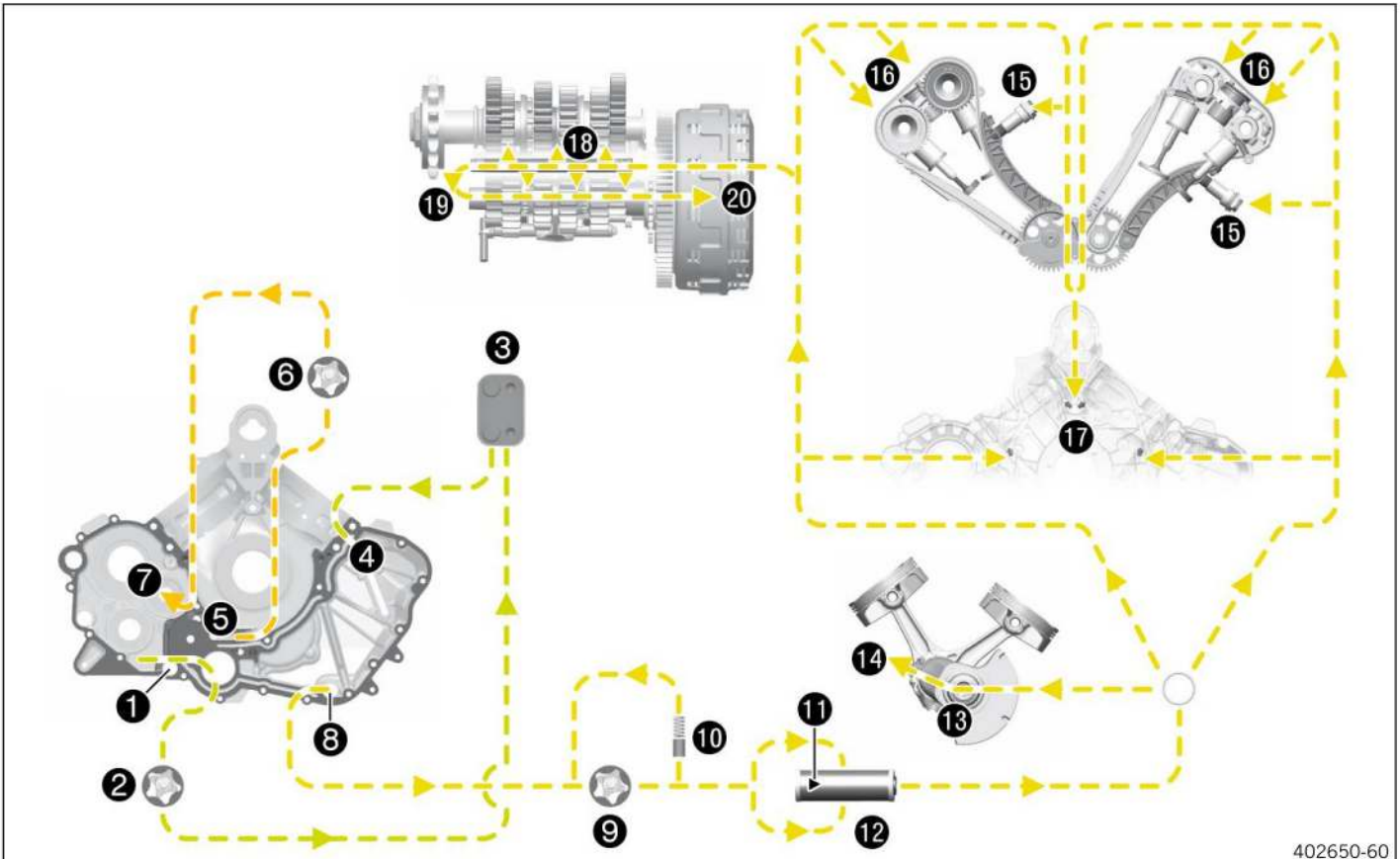

402650-60

### Oil circuit of middle suction pump

- |   |   |
|---|---|
| 1 | Oil screen of oil drain plug in gearbox |
| 2 | Middle suction pump                     |
| 3 | Heat exchanger                          |
| 4 | Oil exit in oil tank                    |

### Oil circuit of left suction pump

- |   |                              |
|---|------------------------------|
| 5 | Crankcase                    |
| 6 | Left suction pump            |
| 7 | Lubricating slots in gearbox |

### Oil circuit of force pump

- |    |   |
|----|---|
| 8  | Oil screen of oil drain plug in oil tank                    |
| 9  | Force pump  |
| 10 | Oil pressure regulator valve                                |
| 11 | Bypass valve  |
| 12 | Oil filter  |
| 13 | Crankshaft  |
| 14 | Oil nozzle for alternator cooling                           |
| 15 | Timing chain tensioner                                      |
| 16 | Camshaft lubrication/oil nozzles for valve gear lubrication |
| 17 | Oil nozzles for piston cooling                              |
| 18 | Oil spray tube  |
| 19 | Oil nozzle for clutch lubrication                           |
| 20 | Clutch  |

## 24.2 Checking the engine oil level

**i Info**  
Oil consumption depends on the riding style and the operating conditions.

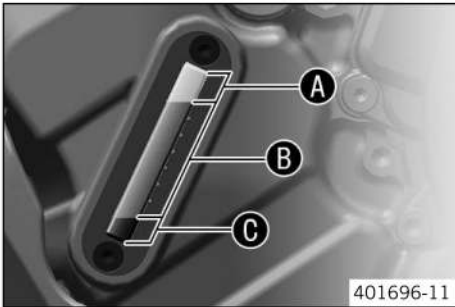

**Condition**  
The engine is at operating temperature.

**Preparatory work**  
– Stand the motorcycle upright on a horizontal surface.

**Main work**  
– Check the engine oil level in the engine oil level viewer.

**i Info**  
After switching off the engine, wait one minute before checking the level.

The engine oil level should be in the upper part of the range **B** of the engine oil level viewer.

- » When the engine oil level is in area **A** of the engine oil level viewer:
  - Do not add engine oil.
- » When the engine oil level is in area **B** of the engine oil level viewer:
  - Engine oil can be added.
- » When the engine oil level is in area **C** of the engine oil level viewer:
  - Add engine oil. (📖 p. 278)

## 24.3 Changing the engine oil and filter, cleaning the oil screens

**⚠ Warning**  
**Danger of scalding** Engine and gear oil get very hot when the motorcycle is ridden.  
– Wear suitable protective clothing and safety gloves.  
– In the event of scalding, rinse the area affected immediately with lukewarm water.

**🌿 Warning**  
**Environmental hazard** Hazardous substances cause environmental damage.  
– Dispose of oils, grease, filters, fuel, cleaning agents, brake fluid, etc., correctly and in compliance with the applicable regulations.

**Preparatory work**  
– Remove the engine guard. (📖 p. 43)

**Main work**  
– Stand the motorcycle on its side stand on a horizontal surface.  
– Place a suitable container under the engine.  
– Remove the oil drain plugs **1** with the magnets, O-rings, and oil screens.

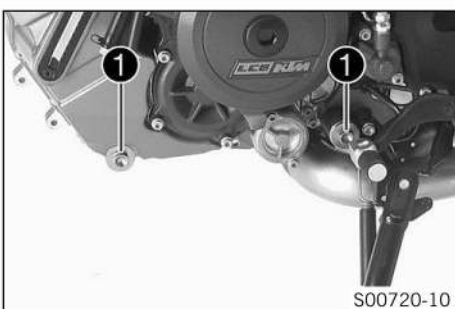

– Remove screws **2**. Remove the oil filter cover **3** with the O-ring.

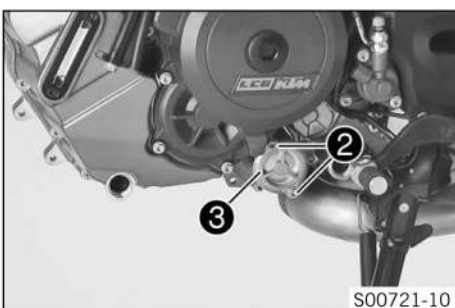

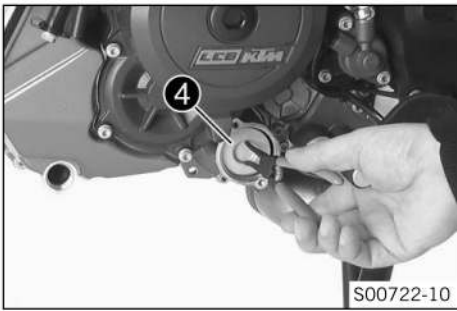

- Pull oil filter **4** out of the oil filter housing.

Circlip pliers reverse (51012011000) (📖 p. 344)

- Completely drain the engine oil.
- Thoroughly clean the parts and sealing surface.

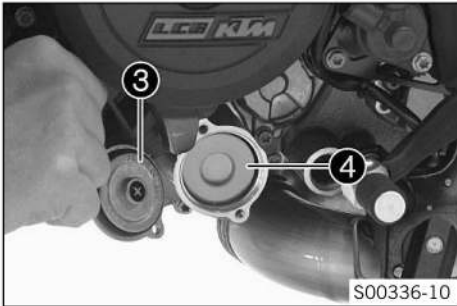

- Insert oil filter **4**.
- Lubricate the O-ring of the oil filter cover. Mount the oil filter cover **3**.

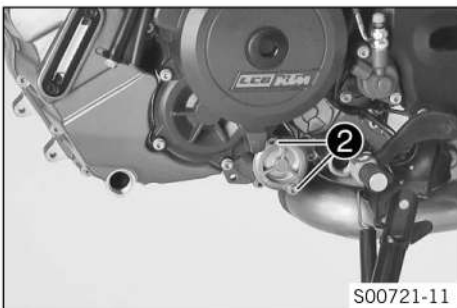

- Mount and tighten screws **2**.

Guideline

Remaining engine screws	M5	6 Nm (4.4 lbf ft)
-------------------------	----	-------------------

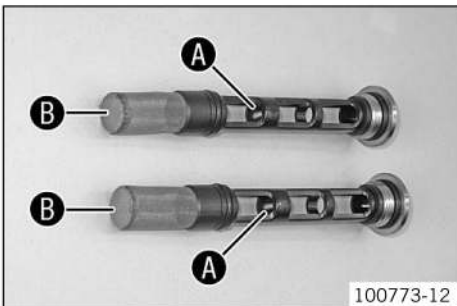

- Thoroughly clean magnets **A** and oil screens **B** of the oil drain plugs.

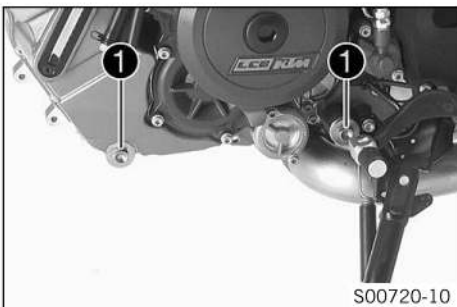

- Mount and tighten the oil drain plugs **1** with the magnets, O-rings, and oil screens.

Guideline

Oil drain plug	M20x1.5	20 Nm (14.8 lbf ft)
----------------	---------	------------------------

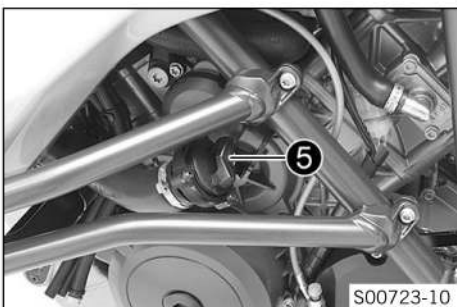

- The oil must be added in two steps.

Engine oil	3.60 l (3.8 qt.)	Outside temperature: $\geq 0\text{ }^{\circ}\text{C}$ ( $\geq 32\text{ }^{\circ}\text{F}$ )	Engine oil (SAE 10W/50) (📖 p. 338)
		Outside temperature: $< 0\text{ }^{\circ}\text{C}$ ( $< 32\text{ }^{\circ}\text{F}$ )	Engine oil (SAE 5W/40) (📖 p. 338)

- Remove screw plug **5** and fill in engine oil.

Engine oil (1st quantity) approx.	3.0 l (3.2 qt.)	Outside temperature: $\geq 0\text{ }^{\circ}\text{C}$ ( $\geq 32\text{ }^{\circ}\text{F}$ )	Engine oil (SAE 10W/50) (📖 p. 338)
-----------------------------------	-----------------	--	---------------------------------------

Engine oil (1st quantity) approx.	3.0 l (3.2 qt.)	Outside temperature: < 0 °C (< 32 °F)	Engine oil (SAE 5W/40) (📖 p. 338)
-----------------------------------	-----------------	---------------------------------------	-----------------------------------

- Mount screw plug ⑤.



**Danger**

**Danger of poisoning** Exhaust gases are toxic and inhaling them may result in unconsciousness and death.

- Always make sure there is sufficient ventilation when running the engine.
- Use an effective exhaust extraction system when starting or running the engine in an enclosed space.

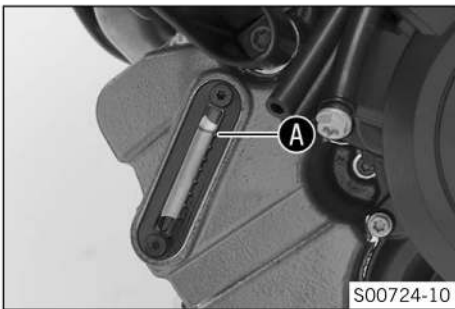

- Start the engine and check that it is oil-tight.
- Remove the screw plug and add the remaining engine oil to the upper marking A on the engine oil level viewer.
- Mount the screw plug.



**Danger**

**Danger of poisoning** Exhaust gases are toxic and inhaling them may result in unconsciousness and death.

- Always make sure there is sufficient ventilation when running the engine.
- Use an effective exhaust extraction system when starting or running the engine in an enclosed space.

- Start the engine and check that it is oil-tight.

**Finishing work**

- Check the engine oil level. (📖 p. 276)
- Install the engine guard. (📖 p. 43)

## 24.4 Adding engine oil



**Info**

Too little engine oil or poor-quality engine oil results in premature wear to the engine. The engine may be damaged if the engine oil level is too high.

**Condition**

The engine is at operating temperature.

**Preparatory work**

- Stand the motorcycle upright on a horizontal surface.
- Check the engine oil level. (📖 p. 276)

**Main work**

- Remove screw plug ①.

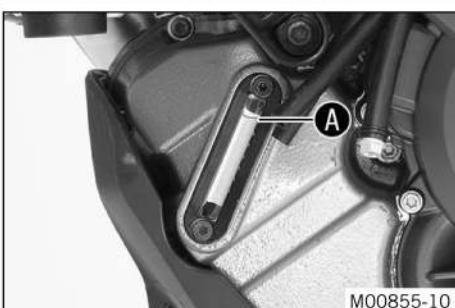
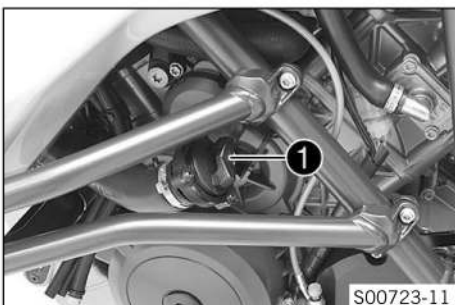

- Add engine oil to the upper marking A on the engine oil level viewer.

**Condition**

Outside temperature: ≥ 0 °C (≥ 32 °F)

Engine oil (SAE 10W/50) (📖 p. 338)

**Condition**

Outside temperature: < 0 °C (< 32 °F)

Engine oil (SAE 5W/40) (📖 p. 338)





**Info**

In order to achieve optimal engine performance, it is not advisable to mix different engine oils.  
KTM recommends changing the engine oil.

- Mount the screw plug.



**Danger**

**Danger of poisoning** Exhaust gases are toxic and inhaling them may result in unconsciousness and death.

- Always make sure there is sufficient ventilation when running the engine.
- Use an effective exhaust extraction system when starting or running the engine in an enclosed space.

- Start the engine and check that it is oil-tight.

**Finishing work**

- Check the engine oil level. (📖 p. 276)

## 24.5 Checking the engine oil pressure



- Check the engine oil level. (📖 p. 276)
- Remove screw ①.

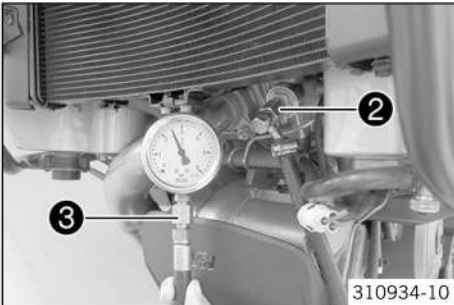

- Mount and tighten special tool ②.

**Guideline**

Oil pressure adapter	M10x1	10 Nm (7.4 lbf ft)
----------------------	-------	--------------------

Oil pressure adapter (77329006000) (📖 p. 354)

- Connect pressure tester ③ without the t-plate on the special tool.

Pressure tester (61029094000) (📖 p. 348)



**Danger**

**Danger of poisoning** Exhaust gases are toxic and inhaling them may result in unconsciousness and death.

- Always make sure there is sufficient ventilation when running the engine.
- Use an effective exhaust extraction system when starting or running the engine in an enclosed space.

- Start the engine and let it warm up.
- Check the engine oil pressure.

<b>Engine oil pressure</b>	
Coolant temperature: $\geq 60\text{ }^{\circ}\text{C}$ ( $\geq 140\text{ }^{\circ}\text{F}$ ) Idle	2.0... 4.8 bar (29... 70 psi)

» If the specification is not reached:

- Check the oil pumps for wear. Check all oil holes for free flow.
- Switch off the engine.



**Warning**

**Danger of burns** Some vehicle components get very hot when the machine is driven.

- Wear appropriate protective clothing and safety gloves. In case of burns, rinse immediately with lukewarm water.

- Remove the special tools.
- Mount and tighten screw ❶.

Guideline

Screw, timing chain tensioner release	M10x1	10 Nm (7.4 lbf ft)
---------------------------------------	-------	--------------------

## 24.6 Removing the oil nozzle for the clutch lubrication

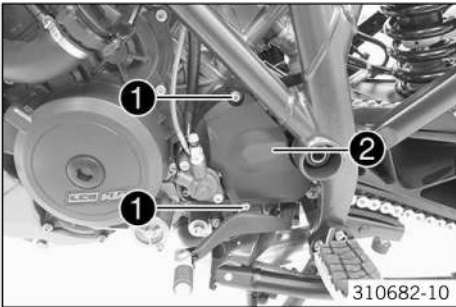

- Remove screws ❶.
- Take off engine sprocket cover ❷.



- Remove screw plug ❸ with O-ring.

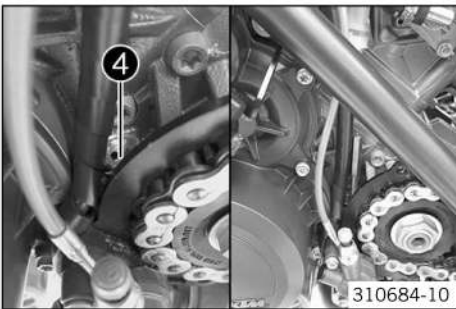

- Remove oil nozzle ❹.

Oil nozzle assembly tool (61229035000) (📖 p. 350)

## 24.7 Checking/cleaning the oil nozzle for clutch lubrication

**Preparatory work**

- Remove the oil nozzle for the clutch lubrication. (📖 p. 280)

**Main work**

- Check that the oil nozzle for clutch lubrication is not blocked.
  - » If the oil nozzle is blocked:
    - Clean the oil nozzle and change as necessary.



**Finishing work**

- Install the oil nozzle for the clutch lubrication. (📖 p. 281)

## 24.8 Installing the oil nozzle for the clutch lubrication

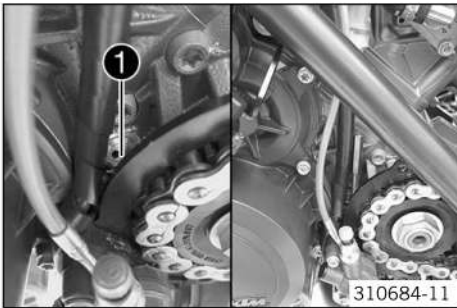

- Mount and tighten oil nozzle **1**.

Guideline

Oil nozzle for clutch lubrication	M6x0.75	4 Nm (3 lbf ft)
-----------------------------------	---------	-----------------

Oil nozzle assembly tool (61229035000) (📖 p. 350)
---

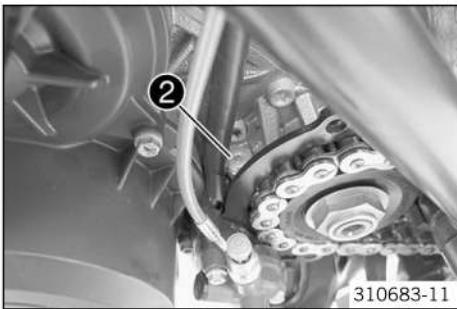

- Mount and tighten screw plug **2** with the O-ring.

Guideline

Plug, clutch lubrication	M10x1	10 Nm (7.4 lbf ft)
--------------------------	-------	--------------------

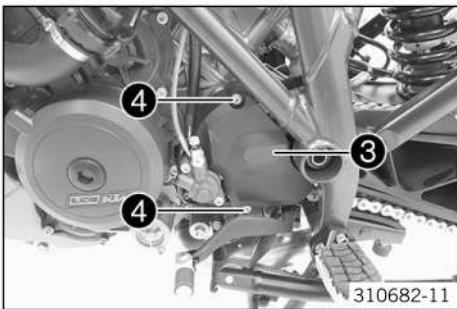

- Position engine sprocket cover **3**.
- Mount and tighten screws **4**.

Guideline

Remaining chassis screws	M6	10 Nm (7.4 lbf ft)
--------------------------	----	--------------------

## 25.1 Alternator - checking the stator winding



**Condition**

The stator is disconnected.

**Stator winding measurement I - check the resistance.**

- $\Omega$  Measure the resistance between the specified points.  
Stator, connector **HQ** pin **1** – Stator, connector **HQ** pin **2**

Alternator	
Stator winding resistance at: 20 °C (68 °F)	0.15... 0.30 $\Omega$

- » If the indicated value does not correspond to the setpoint value:
  - Change the stator.

**Stator winding measurement II - check the resistance.**

- $\Omega$  Measure the resistance between the specified points.  
Stator, connector **HQ** pin **1** – Stator, connector **HQ** pin **3**

Alternator	
Stator winding resistance at: 20 °C (68 °F)	0.15... 0.30 $\Omega$

- » If the indicated value does not correspond to the setpoint value:
  - Change the stator.

**Stator winding measurement III - check the resistance.**

- $\Omega$  Measure the resistance between the specified points.  
Stator, connector **HQ** pin **2** – Stator, connector **HQ** pin **3**

Alternator	
Stator winding resistance at: 20 °C (68 °F)	0.15... 0.30 $\Omega$

- » If the indicated value does not correspond to the setpoint value:
  - Change the stator.

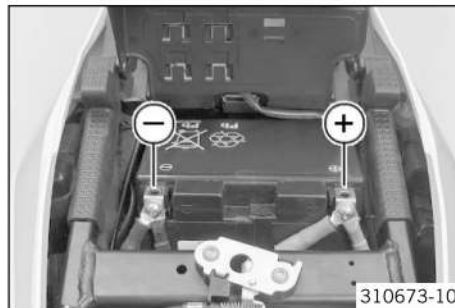

**Stator winding I - check short circuit to ground (terminal 31).**

- $\Omega$  Measure the resistance between the specified points.  
Stator, connector **HQ** pin **1** – Measuring point **Ground(-)**

Resistance	$\infty \Omega$
------------	-----------------

- » If the indicated value does not correspond to the setpoint value:
  - Change the stator.

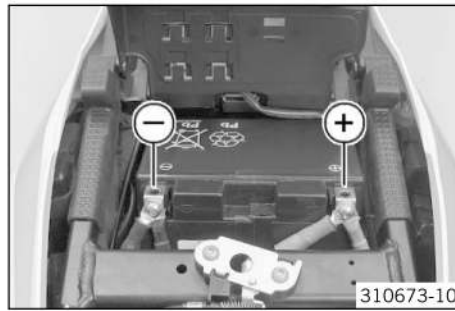

**Stator winding II - check short circuit to ground (terminal 31).**

- $\Omega$  Measure the resistance between the specified points.  
Stator, connector **HQ** pin **2** – Measuring point **Ground(-)**

Resistance	$\infty \Omega$
------------	-----------------

- » If the indicated value does not correspond to the setpoint value:
  - Change the stator.

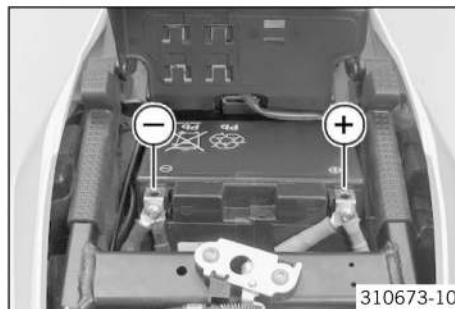

**Stator winding III - check short circuit to ground (terminal 31).**

- $\Omega$  Measure the resistance between the specified points.  
Stator, connector **HQ** pin **3** – Measuring point **Ground(-)**

Resistance	$\infty \Omega$
------------	-----------------

- » If the indicated value does not correspond to the setpoint value:
  - Change the stator.

- Start the motorcycle to check the function. (📖 p. 13)



**Stator winding measurement I - check the voltage.**

- $V$  Measure the voltage between the specified points.  
Stator, connector **HQ** pin **1** – Stator, connector **HQ** pin **2**

**i Info**  
The results of the measurements on the individual coils must not deviate noticeably from each other.

AC generator	
Alternating voltage stator winding at 4000 rpm: 20 °C (68 °F)	$\geq 50 V$

- » If the indicated value does not correspond to the setpoint value:
  - Change the stator.

**Stator winding measurement II - check the voltage.**

- $V$  Measure the voltage between the specified points.  
Stator, connector **HQ** pin **1** – Stator, connector **HQ** pin **3**

**i Info**  
The results of the measurements on the individual coils must not deviate noticeably from each other.

AC generator	
Alternating voltage stator winding at 4000 rpm: 20 °C (68 °F)	$\geq 50 V$

- » If the indicated value does not correspond to the setpoint value:
  - Change the stator.

**Stator winding measurement III - check the voltage.**

- **V** Measure the voltage between the specified points.  
Stator, connector **HQ** pin **2** – Stator, connector **HQ** pin **3**



**Info**

The results of the measurements on the individual coils must not deviate noticeably from each other.

AC generator	
Alternating voltage stator winding at 4000 rpm: 20 °C (68 °F)	≥ 50 V

- » If the indicated value does not correspond to the setpoint value:
  - Change the stator.

## 25.2 Changing spark plugs (air filter removed)

**Condition**

The air filter is removed.

- Remove spring band clamp **1**.

Pliers for spring band clamp (60029057100) (p. 347)

- Pull off the air release hose.

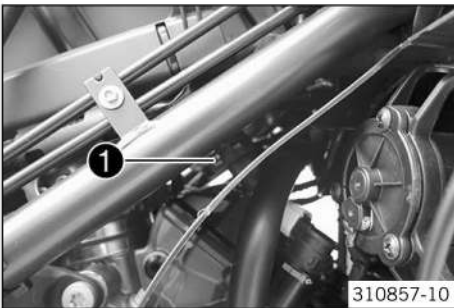

- Remove cable tie(s) **2**.

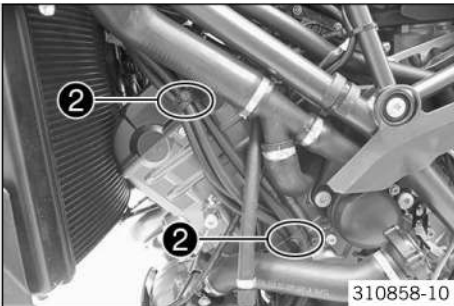

- Remove screws **3**.
- Remove the intake trumpet.



- Raise the lower part of the air filter box and pull it back gently.



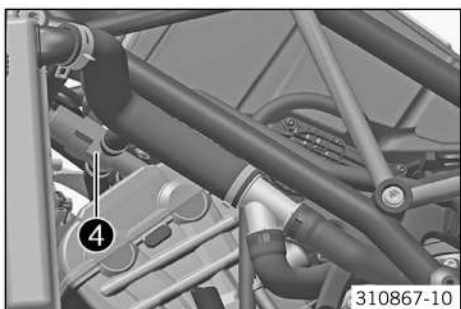

- Remove SAS valve **4** from the holder.

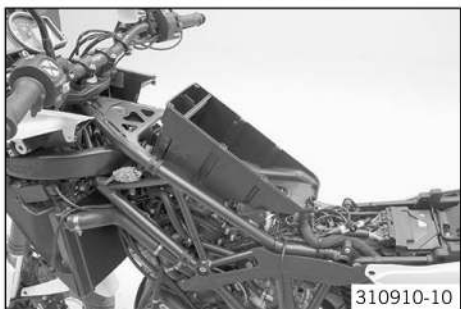

- Take off the lower part of the air filter box.

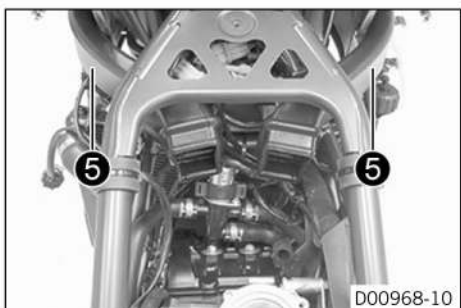

- Remove intake snorkel **5**.

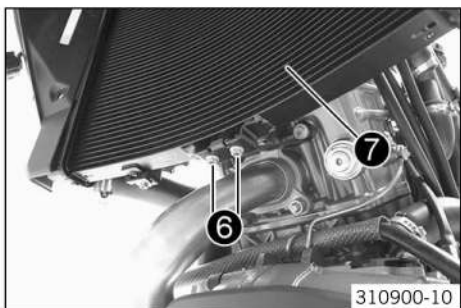

- Remove screws **6**.
- Swing the radiator **7** forward slightly.

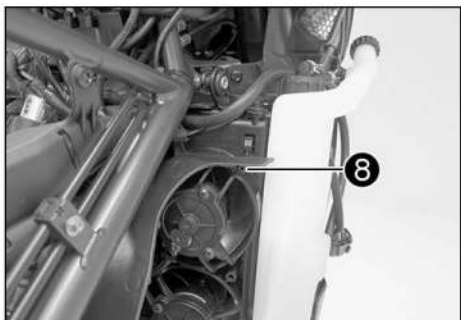

- Remove screw **8**.
- Pull heat protector off the holder from the front and remove protector.

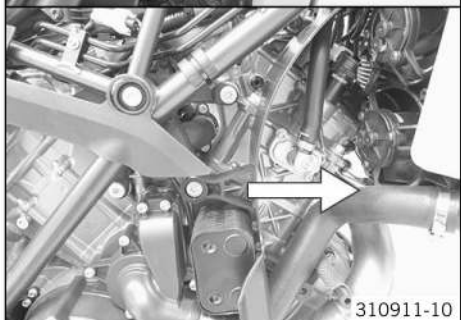

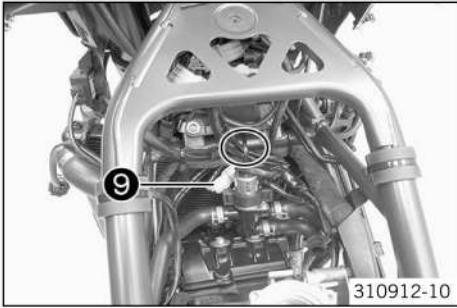

- Remove the cable tie(s).
- Disconnect plug-in connector 9.
- Pull the SAS valve back and fix it into position.

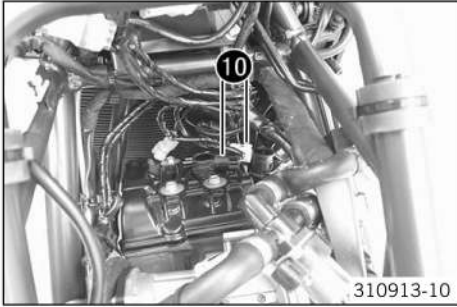

- Disconnect connectors 10 of the ignition coils.

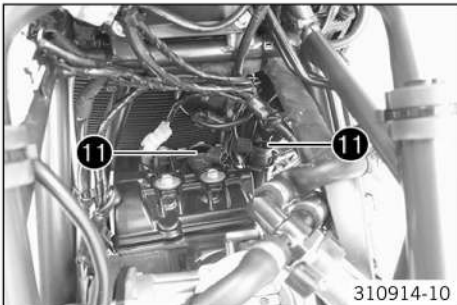

- Remove ignition coils 11.

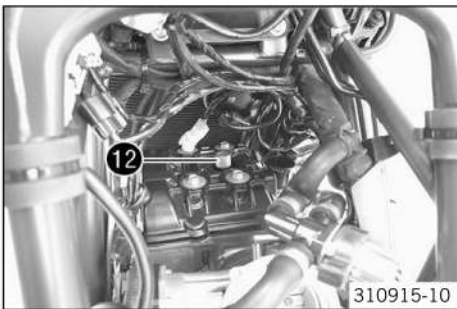

- Remove the spark plug with special tool 12.

Spark plug wrench (77229172000) (p. 353)

- Mount and tighten the new spark plug using the special tool.

Guideline

Spark plug	M12x1.5	18 Nm (13.3 lbf ft)
------------	---------	------------------------



- Remove the spark plug with special tool 12.

Spark plug wrench (77229172000) (p. 353)

- Mount and tighten the new spark plug using the special tool.

Guideline

Spark plug	M10x1	11 Nm (8.1 lbf ft)
------------	-------	--------------------

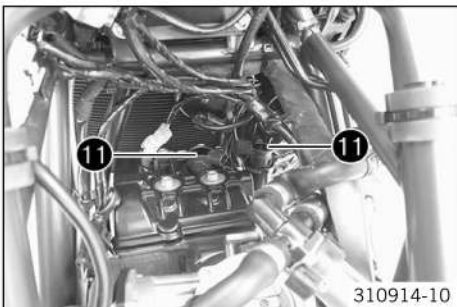

- Mount ignition coils 11.



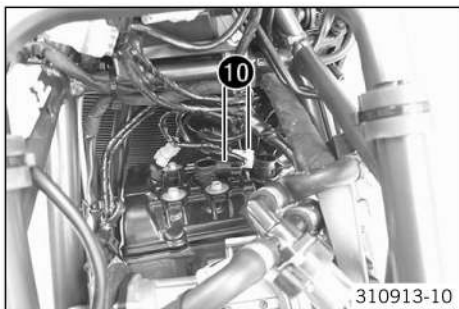

- Plug in connectors **10** of the ignition coils.
- ✓ The cable with the white marking is connected to the outer ignition coil.



- Position SAS valve.
- Join plug-in connector **9**.
- Mount the cable tie(s).



- Position the heat protector and mount to holder.
- Mount and tighten screw **8**.

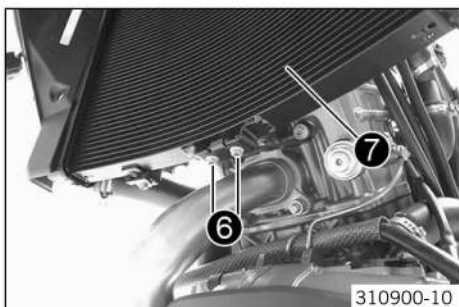
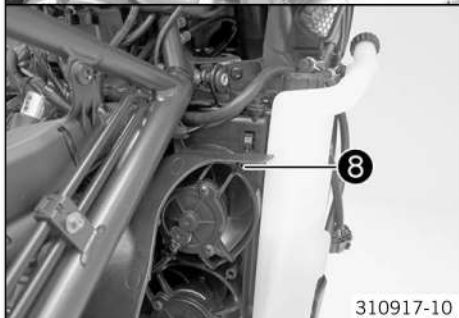

- Position the radiator **7**.
- Mount and tighten screws **6**.

Guideline

Remaining screws, chassis	M5	5 Nm (3.7 lbf ft)
---------------------------	----	-------------------

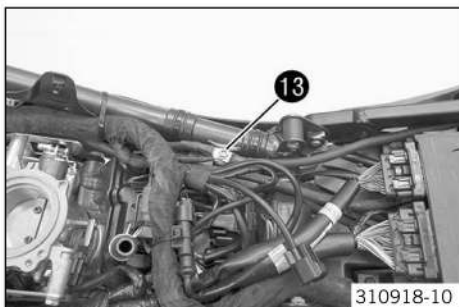

- Remove screw **13** with the washer.

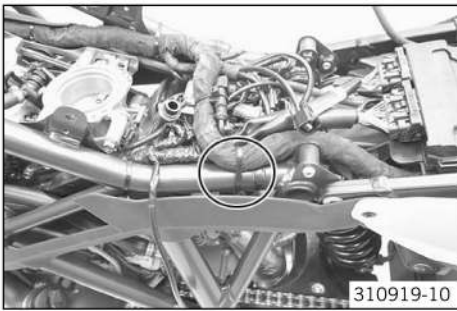

- Remove the cable tie(s).
- Push the cables slightly to the side.

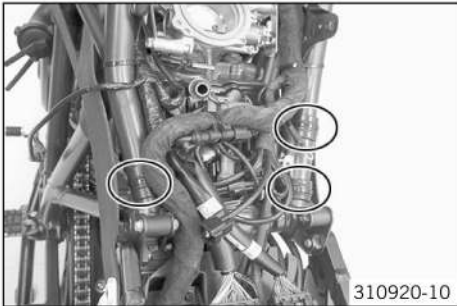

- Remove the cable tie(s).

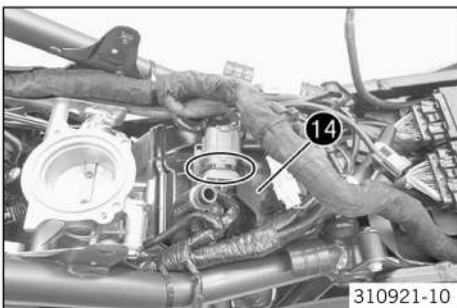

- Remove the cable tie(s).
- Loosen old connector from connector holder 14.
- Remove the plug holder.

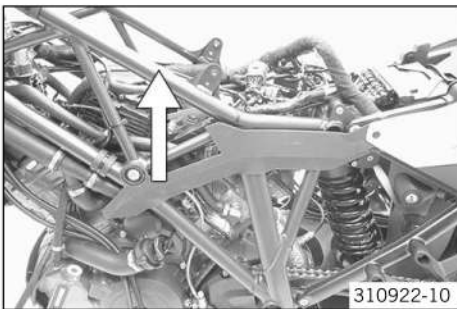

- Lift up the heat protector.

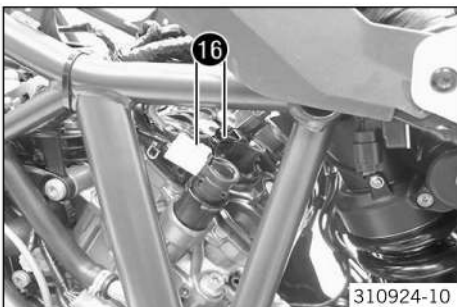

- Disconnect connectors 16 of the ignition coils.

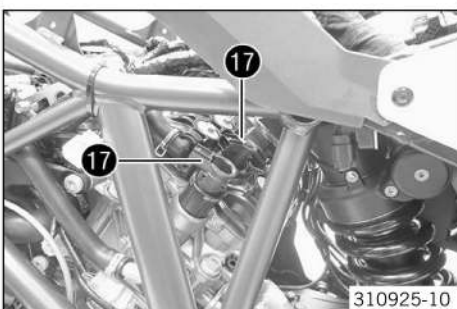

- Remove ignition coils 17.

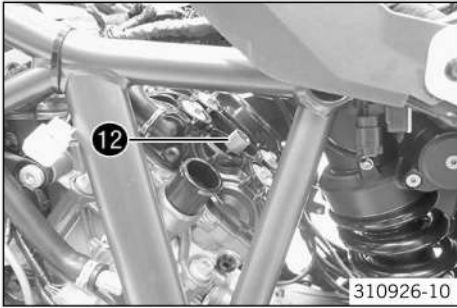

- Remove the spark plug with special tool 12.

Spark plug wrench (77229172000) (📖 p. 353)

- Mount and tighten the new spark plug using the special tool.

Guideline

Spark plug	M12x1.5	18 Nm (13.3 lbf ft)
------------	---------	------------------------

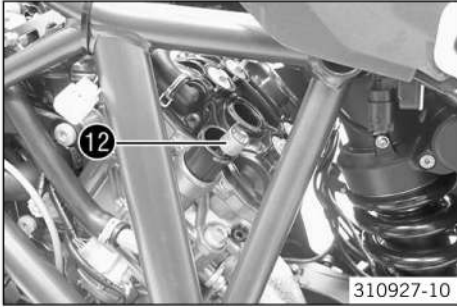

- Remove the spark plug with special tool 12.

Spark plug wrench (77229172000) (📖 p. 353)

- Mount and tighten the new spark plug using the special tool.

Guideline

Spark plug	M10x1	11 Nm (8.1 lbf ft)
------------	-------	--------------------

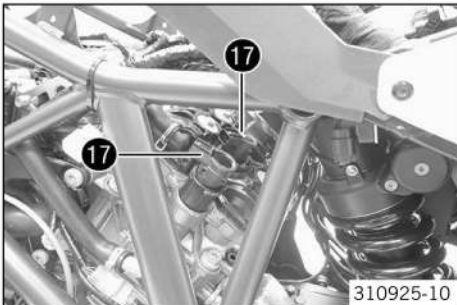

- Mount ignition coils 17.

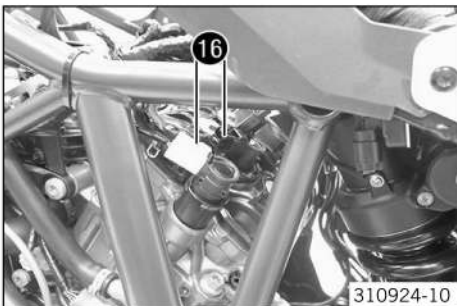

- Plug in connectors 16 of the ignition coils.

✓ The cable with the white marking is connected to the outer ignition coil.

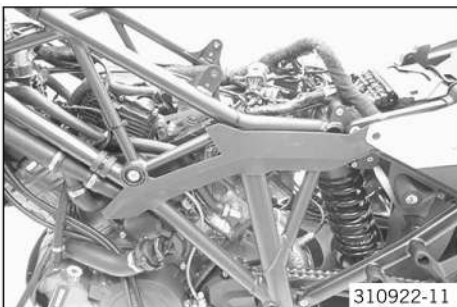

- Position the heat protector.

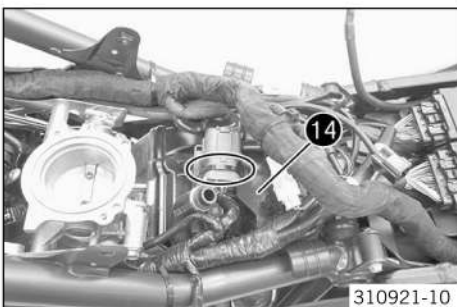

- Position the plug holder.
- Connect all connectors in the connector holder 14.
- Mount the cable tie(s).

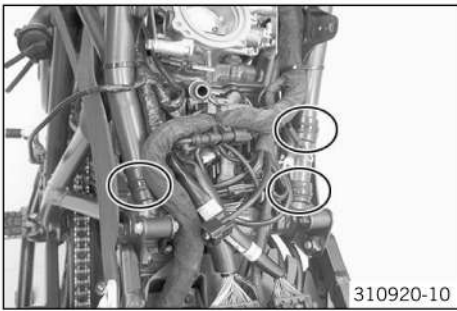

- Mount the cable tie(s).

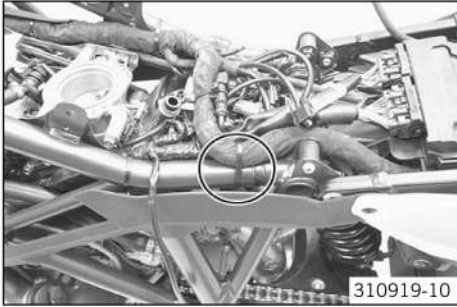

- Route the cable without tension.
- Mount the cable tie(s).

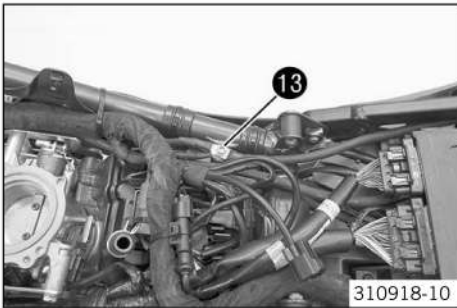

- Mount and tighten screw **13** with the washer.
- Guideline

Remaining chassis screws	M6	10 Nm (7.4 lbf ft)
--------------------------	----	--------------------

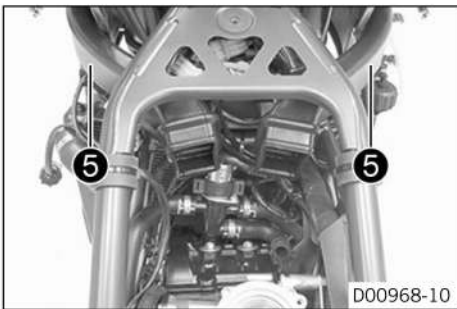

- Mount intake snorkel **5**.

**i Info**  
Ensure that the seals are seated correctly.

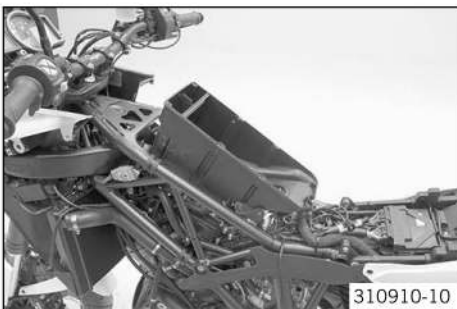

- Position the lower part of the air filter box in the frame.

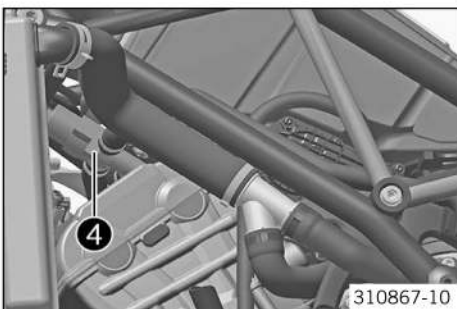

- Mount SAS valve **4** on the holder.



- Position the lower part of the air filter box in the frame.



**Info**

Ensure that the O-rings are seated correctly.



- Position the intake trumpet and mount and tighten screws **3** with the bushing.
- Guideline

Remaining screws, chassis	M5	5 Nm (3.7 lbf ft)
---------------------------	----	-------------------

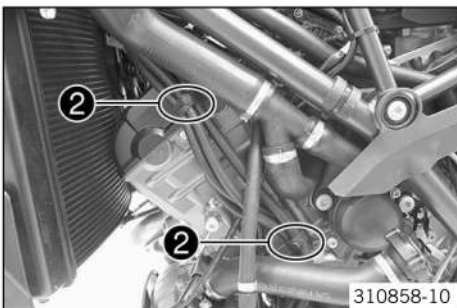

- Route the hose without kinks.
- Mount cable tie(s) **2**.

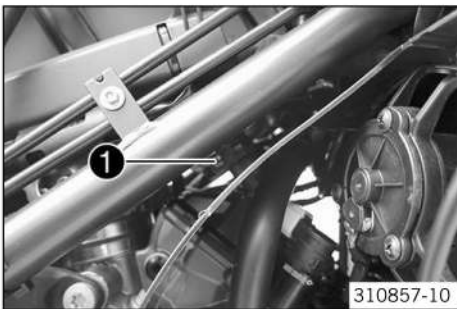

- Mount the vent hose.
- Position spring band clamp **1** with special tool.

Pliers for spring band clamp (60029057100) (📄 p. 347)
---

## 26.1 Removing the throttle valve body

### Preparatory work

- Remove the passenger seat. (📖 p. 72)
- Remove the front rider's seat. (📖 p. 71)
- Remove the crash bar. (📖 p. 32)
- Remove the front side cover. (📖 p. 87)
- Remove the tank cover. (📖 p. 89)
- Remove the mask spoiler. (📖 p. 90)
- Remove the fuel tank. (📖 p. 73)
- Remove the upper part of the air filter box. (📖 p. 66)
- Remove the lower part of the air filter box. (📖 p. 68)

### Main work

- Detach connector ❶.

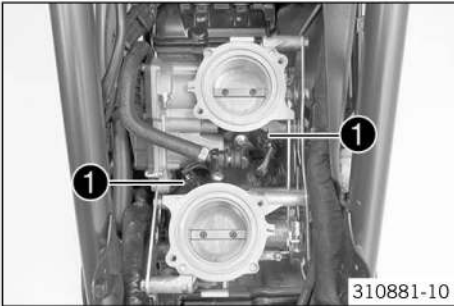

- Detach connector ❷.



- Detach connector ❸.

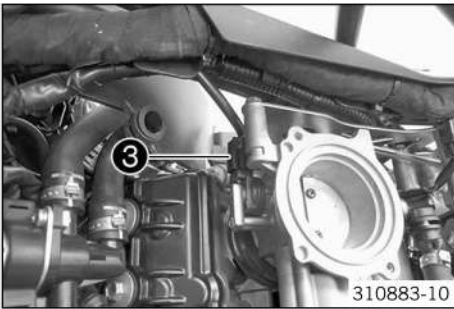

- Lift up the heat protector.

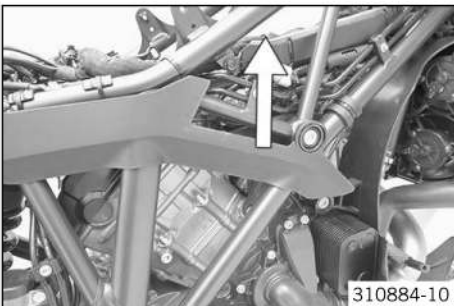

- Loosen clamps ❹.

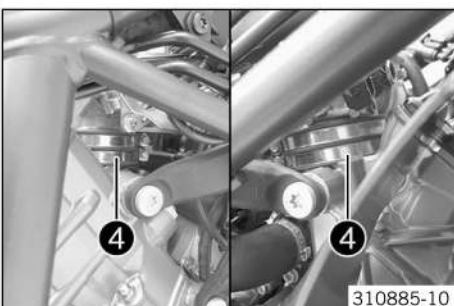

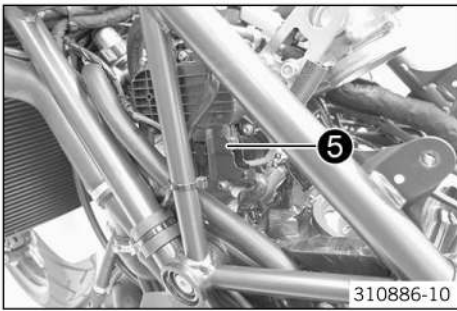

310886-10

- Detach connectors 5 and remove the throttle valve body.



310899-10

- Cover the intake duct with a cloth.

## 26.2 Installing the throttle valve body



310899-10

### Main work

- Remove the cloth from the intake duct.

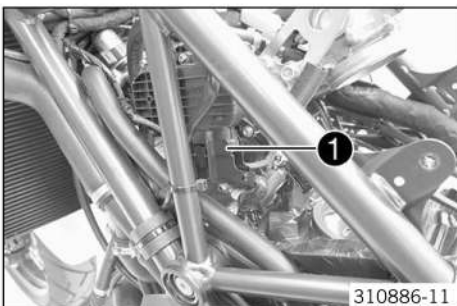

310886-11

- Plug in connector 1.
- Position the throttle valve body.

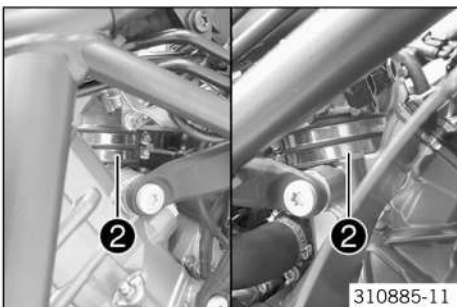

310885-11

- Position and tighten clamps 2.



310884-11

- Position the heat protectors.

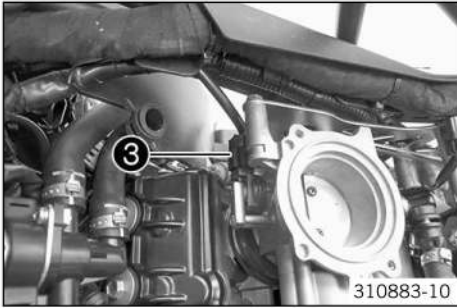

- Plug in connector ③.

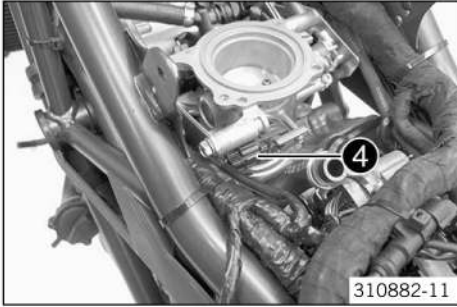

- Plug in connector ④.

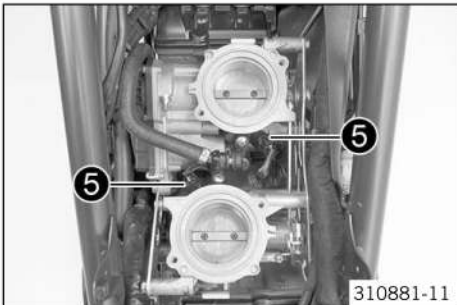

- Plug in connector ⑤.

**Finishing work**

- Install the lower part of the air filter box. (📖 p. 69)
- Install the upper part of the air filter box. (📖 p. 67)
- Install the fuel tank. (📖 p. 74)
- Install the mask spoiler. (📖 p. 92)
- Install the tank cover. (📖 p. 89)
- Install the front side cover. (📖 p. 87)
- Install the crash bar. (📖 p. 32)
- Mount the front rider's seat. (📖 p. 71)
- Mount the passenger seat. (📖 p. 72)
- Execute the initialization run. (📖 p. 294)

**26.3 Executing the initialization run**

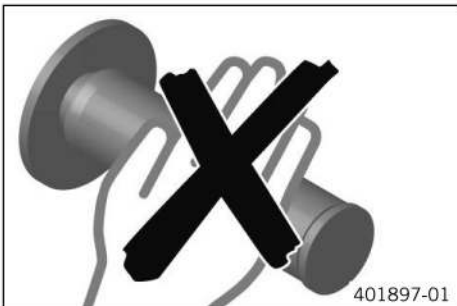

**Condition**

The diagnostic tool is connected and running.

- Execute **"Engine electronics" > "Functions" > "Deleting adaption figures"**.  
 ✓ The adaption figures are deleted.
- Select **"Engine electronics" > "Measured values" > "Temperature sensor - coolant (TW1)"**.  
 ✓ The coolant temperature is displayed during the initialization run.



**Danger**

**Danger of poisoning** Exhaust gases are toxic and inhaling them may result in unconsciousness and death.

- Always make sure there is sufficient ventilation when running the engine.
- Use an effective exhaust extraction system when starting or running the engine in an enclosed space.



- Start the engine without operating the throttle grip.

Guideline

Coolant temperature	< 25 °C (< 77 °F)
---------------------	-------------------

- Let the engine idle until it reaches the specified temperature.

Guideline

Coolant temperature	80... 90 °C (176... 194 °F)
---------------------	-----------------------------



**Info**

Do not operate the throttle grip during the initialization process.

- Switch off the ignition as soon as the specified temperature is reached.



**Info**

If the initialization is not completed or the initialization process is interrupted, the entire process must be restarted.

## 26.4 Checking the CO adjustment using the KTM diagnostics tool



**Condition**

The diagnostic tool is connected and running.

- Select "**Engine electronics**" > "**Functions**" > "**CO adjustment when idling**".
- Confirm the warning note using "**Next**".
- Check the position of the bars in the measurement range for both cylinders.
  - » The bars are in the middle of the green area of the measurement range.
    - Quit the function using "**Cancel**".
  - » The bars are not in the middle of the green area of the measurement range.
    - Select "**cylinder 1**" or "**cylinder 2**".
    - Using the + button or - button to position to bars in the middle of the measurement range.
    - Quit the function using "**Save**".
- Quit the process using "**Execute**".

**27.1 engine**

Design	2-cylinder 4-stroke Otto engine, 75° V arrangement, water-cooled
Displacement	1,301 cm <sup>3</sup> (79.39 cu in)
Stroke	71 mm (2.8 in)
Bore	108 mm (4.25 in)
Compression ratio	13.1:1
Idle speed	1,300... 1,500 rpm
Control	DOHC, 4 valves per cylinder, chain-driven
Valve - valve plate diameter	
Intake	42 mm (1.65 in)
Exhaust	34 mm (1.34 in)
Valve clearance	
Exhaust at: 20 °C (68 °F)	0.25... 0.30 mm (0.0098... 0.0118 in)
Intake at: 20 °C (68 °F)	0.10... 0.15 mm (0.0039... 0.0059 in)
Crankshaft bearing	Sleeve bearing
Conrod bearing	Sleeve bearing
Piston	Forged light alloy
Piston ring	1 upper compression (rectangular) ring, 1 lower compression ring, 1 oil scraper ring
Engine lubrication	Pressure circulation lubrication with three rotary pumps
Primary transmission	40:76
Clutch	Antihopping clutch in oil bath/hydraulically operated
Transmission	6-speed claw gears
Transmission ratio	
1st gear	12:35
2nd gear	15:32
3rd gear	18:30
4th gear	20:27
5th gear	24:27
6th gear	35:32
Mixture preparation	Electronically controlled fuel injection
Ignition system	Contactless controlled fully electronic ignition with digital ignition adjustment
Alternator	12 V, 450 W
Spark plug	
Inside spark plug	NGK LKAR9BI-10
Outside spark plug	NGK LMAR7DI-10
Electrode gap, spark plug	1.0 mm (0.039 in)
Cooling	Water cooling, permanent circulation of coolant by water pump
Cold start device	Electric starter

**27.2 Tolerance, engine wear limits**

Camshaft - cam height	
Intake	39.150... 39.291 mm (1.54134... 1.54689 in)
Exhaust	38.390... 38.542 mm (1.51141... 1.5174 in)
Camshaft - bearing pin	23.959... 23.980 mm (0.94327... 0.94409 in)
Camshaft bearing - radial clearance	
New condition	0.020... 0.054 mm (0.00079... 0.00213 in)
Wear limit	0.065 mm (0.00256 in)
Valve guide - diameter	
New condition	6.004... 6.016 mm (0.23638... 0.23685 in)

Wear limit	6.150 mm (0.24213 in)
Valve - sealing seat width	
Intake: New condition	0.90 mm (0.0354 in)
Intake: Wear limit	1.5 mm (0.059 in)
Exhaust: New condition	1.0 mm (0.039 in)
Exhaust: Wear limit	2.0 mm (0.079 in)
Valve - run-out	
Intake: on the valve plate	≤ 0.03 mm (≤ 0.0012 in)
Exhaust: on the valve plate	≤ 0.03 mm (≤ 0.0012 in)
Valve - valve stem diameter	
Exhaust	5.956... 5.970 mm (0.23449... 0.23504 in)
Intake	5.966... 5.980 mm (0.23488... 0.23543 in)
Valve spring - length	
New condition	42.70 mm (1.6811 in)
Wear limit	41.8 mm (1.646 in)
Cylinder head - bearing hole of camshaft	24.000... 24.021 mm (0.94488... 0.94571 in)
Cylinder/cylinder head - sealing area distortion	≤ 0.05 mm (≤ 0.002 in)
Cylinder - bore diameter	
Size I	108.000... 108.012 mm (4.25196... 4.25243 in)
Size II	108.012... 108.025 mm (4.25243... 4.25294 in)
Piston - diameter	
Size I	107.960... 107.990 mm (4.25039... 4.25157 in)
Size II	107.970... 108.000 mm (4.25078... 4.25196 in)
Piston/cylinder - mounting clearance	
Size I	0.010... 0.042 mm (0.00039... 0.00165 in)
Size II	0.012... 0.052 mm (0.00047... 0.00205 in)
Wear limit	0.10 mm (0.0039 in)
Piston - piston pin hole diameter	20.010... 20.020 mm (0.78779... 0.78819 in)
Piston ring	
Width, first ring (rectangular ring)	1.170... 1.200 mm (0.04606... 0.04724 in)
Width, second ring (lower compression ring)	1.170... 1.200 mm (0.04606... 0.04724 in)
Width, oil scraper ring	1.970... 2.000 mm (0.07756... 0.07874 in)
Piston ring - groove clearance	
First ring (rectangular ring)	≤ 0.08 mm (≤ 0.0031 in)
Second ring (lower compression ring)	≤ 0.08 mm (≤ 0.0031 in)
Oil scraper ring	≤ 0.06 mm (≤ 0.0024 in)
Piston ring end gap	
First ring (rectangular ring)	≤ 0.50 mm (≤ 0.0197 in)
Second ring (lower compression ring)	≤ 0.60 mm (≤ 0.0236 in)
Oil scraper ring	≤ 0.60 mm (≤ 0.0236 in)
Piston pin - diameter	19.995... 20.000 mm (0.7872... 0.7874 in)
Connecting rod - diameter of upper conrod eye	20.007... 20.013 mm (0.78768... 0.78791 in)
Connecting rod - axial clearance of lower conrod bearing	
New condition	0.15... 0.35 mm (0.0059... 0.0138 in)
Wear limit	0.40 mm (0.0157 in)
Connecting rod - radial clearance of lower conrod bearing	
New condition	0.030... 0.060 mm (0.00118... 0.00236 in)
Wear limit	0.080 mm (0.00315 in)
Connecting rod - large end width	20.950... 21.000 mm (0.8248... 0.82677 in)
Crankshaft - axial clearance	
New condition	0.10... 0.40 mm (0.0039... 0.0157 in)
Wear limit	1.00 mm (0.0394 in)

Crankshaft - crank pin width	42.100... 42.150 mm (1.65748... 1.65945 in)
Crankshaft - crank pin diameter	
Yellow	41.978... 41.989 mm (1.65267... 1.65311 in)
Blue	41.990... 42.000 mm (1.65315... 1.65354 in)
Red	42.001... 42.011 mm (1.65358... 1.65397 in)
Crankshaft - main bearing diameter	
Yellow	52.965... 52.975 mm (2.08523... 2.08563 in)
Blue	52.976... 52.985 mm (2.08567... 2.08602 in)
Red	52.986... 52.995 mm (2.08606... 2.08641 in)
Crankshaft - radial clearance of main bearing	
New condition	0.025... 0.055 mm (0.00098... 0.00217 in)
Wear limit	0.10 mm (0.0039 in)
Crankshaft - step bearing diameter	27.985... 28.000 mm (1.10177... 1.10236 in)
Crankshaft - radial clearance of step bearing	
New condition	0.030... 0.070 mm (0.00118... 0.00276 in)
Wear limit	0.090 mm (0.00354 in)
Clutch facing disc - thickness	
New condition	2.92... 3.08 mm (0.115... 0.1213 in)
Wear limit	2.85 mm (0.1122 in)
Intermediate disk - thickness	
New condition	1.55... 1.65 mm (0.061... 0.065 in)
Wear limit	1.45 mm (0.0571 in)
Clutch discs - thickness of total package	
New condition	47.20... 48.00 mm (1.8583... 1.8898 in)
Wear limit	46.50 mm (1.8307 in)
Clutch spring - length	≥ 43.0 mm (≥ 1.693 in)
Clutch basket - thrust surface of clutch facing discs	
Wear limit	0.5 mm (0.02 in)
Oil pressure regulator valve - minimum spring length	39 mm (1.54 in)
Oil pumps	
Clearance between external rotor and engine case	0.20... 0.40 mm (0.0079... 0.0157 in)
Clearance between external rotor and internal rotor	0.10... 0.25 mm (0.0039... 0.0098 in)
Axial clearance	0.04... 0.25 mm (0.0016... 0.0098 in)
Engine oil pressure	
Coolant temperature: ≥ 60 °C (≥ 140 °F) Idle	2.0... 4.8 bar (29... 70 psi)
Oil consumption	
After the vehicle is run-in	≤ 0.6 l/1.000 km (≤ 0.6 qt./600 mi)
	<div style="border: 1px solid black; padding: 5px;">  <b>Info</b>  Oil consumption depends on the riding style and the operating conditions. </div>
Shift fork	
Thickness at leaf	4.85... 4.95 mm (0.1909... 0.1949 in)
Clearance in the sliding gear groove: New condition	0.35... 0.55 mm (0.0138... 0.0217 in)
Clearance in the sliding gear groove: Wear limit	0.70 mm (0.0276 in)
Shift shaft - play in sliding plate/shift quadrant	0.40... 0.80 mm (0.0157... 0.0315 in)
Sliding gear - width of shift fork groove	5.30... 5.40 mm (0.2087... 0.2126 in)
Transmission shaft - axial clearance	0.05... 0.15 mm (0.002... 0.0059 in)

## 27.3 Engine tightening torques

Screw, damping plate	EJOT ALtracs® M6x14	10 Nm (7.4 lbf ft)	Loctite® 243™
Screw, retaining bracket, valve cover, rear	EJOT ALtracs® M6x10	10 Nm (7.4 lbf ft)	–
Hose clip, intake flange	M4	1.5 Nm (1.11 lbf ft)	–
Oil nozzle	M5	2 Nm (1.5 lbf ft)	Loctite® 243™
Remaining engine screws	M5	6 Nm (4.4 lbf ft)	–
Screw, bearing retainer	M5	6 Nm (4.4 lbf ft)	Loctite® 243™
Screw, bearing shells retaining bracket	M5	6 Nm (4.4 lbf ft)	Loctite® 243™
Screw, engine oil level viewer	M5	4 Nm (3 lbf ft)	–
Screw, gear sensor	M5	6 Nm (4.4 lbf ft)	Loctite® 243™
Screw, pulse generator	M5	6 Nm (4.4 lbf ft)	Loctite® 243™
Swing angle sensor screw	M5	5 Nm (3.7 lbf ft)	Loctite® 243™
Bleeder screw, water pump cover	M6	10 Nm (7.4 lbf ft)	–
Freewheel ring bolt	M6 – 10.9	15 Nm (11.1 lbf ft)	Loctite® 648™
Nut, cylinder head	M6	9 Nm (6.6 lbf ft)	–
Plug, vacuum connection	M6	5 Nm (3.7 lbf ft)	Loctite® 243™
Remaining engine screws	M6	10 Nm (7.4 lbf ft)	–
Screw, camshaft bearing support	M6 – 10.9	10 Nm (7.4 lbf ft)	–
Screw, clutch cover	M6	10 Nm (7.4 lbf ft)	–
Screw, clutch spring	M6	12 Nm (8.9 lbf ft)	–
Screw, coolant connection on cylinder head	M6	10 Nm (7.4 lbf ft)	–
Screw, engine case	M6x60	10 Nm (7.4 lbf ft)	–
Screw, engine case	M6x80	10 Nm (7.4 lbf ft)	–
Screw, engine case	M6x90	10 Nm (7.4 lbf ft)	–
Screw, freewheel holder	M6	10 Nm (7.4 lbf ft)	Loctite® 243™
Screw, locking lever	M6	10 Nm (7.4 lbf ft)	Loctite® 243™
Screw, oil pump cover	M6	10 Nm (7.4 lbf ft)	Loctite® 243™
Screw, shift drum locating	M6	10 Nm (7.4 lbf ft)	Loctite® 243™
Screw, shift lever	M6	18 Nm (13.3 lbf ft)	Loctite® 243™
Screw, starter motor	M6	10 Nm (7.4 lbf ft)	–
Screw, stator	M6	10 Nm (7.4 lbf ft)	Loctite® 243™
Screw, valve cover	M6	10 Nm (7.4 lbf ft)	–
Screw, water pump cover	M6	10 Nm (7.4 lbf ft)	–
Screw, water pump wheel	M6	10 Nm (7.4 lbf ft)	Loctite® 243™
Stud, chain shaft	M6	8 Nm (5.9 lbf ft)	–
Nozzle 100	M6x0.75	4 Nm (3 lbf ft)	Loctite® 243™
Engine brace screws	M8	20 Nm (14.8 lbf ft)	Loctite® 243™
Plug, crankshaft retainer	M8	15 Nm (11.1 lbf ft)	–
Screw, camshaft bearing support	M8 – 10.9	Step 1 10 Nm (7.4 lbf ft) Step 2 18 Nm (13.3 lbf ft)	–
Screw, camshaft bearing support	M8 – 10.9	Step 1 8.5 Nm (6.27 lbf ft) Step 2 14.5 Nm (10.7 lbf ft)	Only applies when using: Hex key bit (61229025000) (  p. 350)
Screw, engine case	M8	18 Nm (13.3 lbf ft)	–
Screw, timing chain guide rail	M8	15 Nm (11.1 lbf ft)	Loctite® 243™
Stud, exhaust flange	M8	10 Nm (7.4 lbf ft)	–
Timing chain tensioning rail screw	M8	15 Nm (11.1 lbf ft)	Loctite® 243™
Screw, engine bearer	M10	45 Nm (33.2 lbf ft)	–

Oil pressure sensor	M10x1	10 Nm (7.4 lbf ft)	–
Plug, cam lever axis	M10x1	15 Nm (11.1 lbf ft)	–
Plug, clutch lubrication	M10x1	10 Nm (7.4 lbf ft)	–
Screw plug, spreading transmission lock	M10x1	12 Nm (8.9 lbf ft)	–
Screw, conrod bearing	M10x1	Step 1 25 Nm (18.4 lbf ft) Step 2 30 Nm (22.1 lbf ft) Step 3 90°	–
Screw, timing chain tensioner release	M10x1	10 Nm (7.4 lbf ft)	–
Spark plug	M10x1	11 Nm (8.1 lbf ft)	–
Cylinder head screw	M11x1.5	Tightening sequence: Using a crisscross pattern Step 1 15 Nm (11.1 lbf ft) Step 2 30 Nm (22.1 lbf ft) Step 3 90° Step 4 90°	Lubricated with engine oil
Coolant temperature sensor	M12x1.5	12 Nm (8.9 lbf ft)	–
Rotor screw	M12x1.5	115 Nm (84.8 lbf ft)	–
Spark plug	M12x1.5	18 Nm (13.3 lbf ft)	–
Nut of engine sprocket	M20x1.5	100 Nm (73.8 lbf ft)	<b>Loctite® 243™</b>
Oil drain plug	M20x1.5	20 Nm (14.8 lbf ft)	–
Nut, inner clutch hub	M22x1.5	120 Nm (88.5 lbf ft)	<b>Loctite® 243™</b>
Plug, timing-chain tensioner	M24x1.5	25 Nm (18.4 lbf ft)	–
Screw in alternator cover	M24x1.5	8 Nm (5.9 lbf ft)	–
Nut, primary gear	M33LHx1.5	130 Nm (95.9 lbf ft)	<b>Loctite® 243™</b>

## 27.4 Capacities

### 27.4.1 Engine oil

Engine oil	3.60 l (3.8 qt.)	Outside temperature: ≥ 0 °C (≥ 32 °F)	Engine oil (SAE 10W/50) (📖 p. 338)
		Outside temperature: < 0 °C (< 32 °F)	Engine oil (SAE 5W/40) (📖 p. 338)

### 27.4.2 Coolant

Coolant	2.40 l (2.54 qt.)	Coolant (📖 p. 338)
---------	-------------------	--------------------

### 27.4.3 Fuel

Fuel reserve, approx.	4 l (1.1 US gal)	
Total fuel tank capacity, approx.	30 l (7.9 US gal)	Super unleaded (ROZ 95/RON 95/PON 91) (📖 p. 339)

## 27.5 Chassis

Frame	Lattice frame made of chrome molybdenum steel tubing, powder-coated
Fork	<b>WP Performance SystemsSemi-active Suspension</b>
Shock absorber	<b>WP Performance SystemsSemi-active Suspension</b>
Suspension travel	
Front	200 mm (7.87 in)
Rear	200 mm (7.87 in)
Brake system	
Front	Double disc brake with radially mounted four-pot brake calipers, floating brake discs
Rear	Single disc brake with dual-piston brake caliper, floating brake disc
Brake discs - diameter	
Front	320 mm (12.6 in)
Rear	267 mm (10.51 in)
Brake discs - wear limit	
Front	4 mm (0.16 in)
Rear	4.5 mm (0.177 in)
Tire air pressure, solo/with passenger/full payload	
Front: with cold tires	2.4 bar (35 psi)
Rear: with cold tires	2.9 bar (42 psi)
Secondary drive ratio	17:42
Chain	5/8 x 5/16" (525) X-ring
Steering head angle	64°
Wheelbase	1,560±15 mm (61.42±0.59 in)
Seat height, unloaded	860/875 mm (860/875 in)
Ground clearance, unloaded	220 mm (8.66 in)
Weight without fuel, approx.	229 kg (505 lb.)
Maximum permissible front axle load	175 kg (386 lb.)
Maximum permissible rear axle load	285 kg (628 lb.)
Maximum permissible total weight	460 kg (1,014 lb.)

## 27.6 Electrical system

Battery	YTZ14S	Battery voltage: 12 V Nominal capacity: 11.2 Ah maintenance-free
Fuse	58011109110	10 A
Fuse	58011109115	15 A
Fuse	58011109125	25 A
Fuse	58011109130	30 A
Low beam	H11/socket PGJ19-2	12 V 55 W
High beam	H11/socket PGJ19-2	12 V 55 W
Parking light	LED	
Cornering light	LED	
Instrument lights and indicator lamps	LED	
Turn signal (Super Adventure EU/FR/AU/JP)	LED	
Tail light	LED	
Brake light	LED	
License plate lamp	LED	

## 27.7 Tires

Front tires	Rear tires
<b>120/70 ZR 19 M/C 60W TL</b> Continental ContiTrailATTACK 2 K	<b>170/60 ZR 17 M/C 72W TL</b> Continental ContiTrailATTACK 2 K
The tires specified represent one of the possible series production tires. Additional information is available in the Service section under: <a href="http://www.ktm.com">http://www.ktm.com</a>	

## 27.8 Fork

Fork part number	14.18.10.26	
Fork	<b>WP Performance SystemsSemi-active Suspension</b>	
Spring length with preload spacer(s)	440 mm (17.32 in)	
Spring rate	Medium (standard)	
	12 N/mm (69 lb/in)	
Fork length	885 mm (34.84 in)	
Fork oil, fork leg, left	680 ml (22.99 fl. oz.)	Fork oil (SAE 4) (48601166S1) (📖 p. 339)
Fork oil, fork leg, right	430 ml (14.54 fl. oz.)	Fork oil (SAE 4) (48601166S1) (📖 p. 339)

## 27.9 Shock absorber

Shock absorber article number	01.18.10.26	
Shock absorber	<b>WP Performance SystemsSemi-active Suspension</b>	
Spring rate	Medium (standard)	
	160 N/mm (914 lb/in)	
Spring length	200 mm (7.87 in)	
Static sag	25 mm (0.98 in)	

## 27.10 Chassis tightening torques

Nut, passenger seat heating switch	PG21	2 Nm (1.5 lbf ft)	–
Nut, tire pressure sensor	ISO 10V2	12 Nm (8.9 lbf ft)	<b>Loctite® 2701™</b>
Screw, fixed grip handlebar	<b>EJOT Spiralform®</b> M4x6-K	2.7 Nm (1.99 lbf ft)	–
Screw, combination switch, left	M4	2 Nm (1.5 lbf ft)	–
Screw, side stand switch	M4	2 Nm (1.5 lbf ft)	–
Remaining screws, chassis	M5	5 Nm (3.7 lbf ft)	–
Screw, brake line holder on frame	M5	2 Nm (1.5 lbf ft)	–
Screw, brake line holder on swingarm	M5	5 Nm (3.7 lbf ft)	–
Screw, cable channel	M5	5 Nm (3.7 lbf ft)	–
Screw, cable guide, wheel speed sensor, rear	M5	3 Nm (2.2 lbf ft)	–
Screw, chain sliding guard	M5	5 Nm (3.7 lbf ft)	–
Screw, combination switch, right	M5	3.5 Nm (2.58 lbf ft)	–
Screw, cover part	M5	3.5 Nm (2.58 lbf ft)	–
Screw, filler cap	M5	3 Nm (2.2 lbf ft)	–
Screw, foot brake lever stub	M5	6 Nm (4.4 lbf ft)	<b>Loctite® 243™</b>
Screw, fuel level sensor	M5	3 Nm (2.2 lbf ft)	–
Screw, heat guard on main silencer	M5	4 Nm (3 lbf ft)	–
Screw, wind shield	M5	3.5 Nm (2.58 lbf ft)	–
Spoke nipple	M5	5 Nm (3.7 lbf ft)	–
Ground fitting on frame	M6	6 Nm (4.4 lbf ft)	–
Nut, ABS unit fixation	M6	8 Nm (5.9 lbf ft)	–
Remaining chassis nuts	M6	10 Nm (7.4 lbf ft)	–
Remaining chassis screws	M6	10 Nm (7.4 lbf ft)	–



Screw, acceleration sensor	M6	6 Nm (4.4 lbf ft)	–
Screw, angle sensor	M6	6 Nm (4.4 lbf ft)	Loctite® 243™
Screw, ball joint of push rod on foot brake cylinder	M6	10 Nm (7.4 lbf ft)	Loctite® 243™
Screw, battery terminal	M6	4.5 Nm (3.32 lbf ft)	–
Screw, brake line holder on bottom triple clamp	M6	10 Nm (7.4 lbf ft)	–
Screw, cable channel	M6	5 Nm (3.7 lbf ft)	–
Screw, chain guide	M6	5 Nm (3.7 lbf ft)	–
Screw, clutch assembly	M6	5 Nm (3.7 lbf ft)	–
Screw, cooler retaining bracket	M6	7 Nm (5.2 lbf ft)	–
Screw, cover part	M6	6 Nm (4.4 lbf ft)	–
Screw, engine guard	M6	10 Nm (7.4 lbf ft)	–
Screw, foot brake cylinder	M6	10 Nm (7.4 lbf ft)	Loctite® 243™
Screw, front brake disc	M6	14 Nm (10.3 lbf ft)	Loctite® 243™
Screw, fuel pump	M6	6 Nm (4.4 lbf ft)	–
Screw, fuel tank	M6	10 Nm (7.4 lbf ft)	–
Screw, fuel tap	M6	6 Nm (4.4 lbf ft)	–
Screw, lower rear part	M6	6 Nm (4.4 lbf ft)	–
Screw, magnetic holder on side stand	M6	6 Nm (4.4 lbf ft)	Loctite® 243™
Screw, rear brake disc	M6	14 Nm (10.3 lbf ft)	Loctite® 243™
Screw, retaining bracket, angle sensor	M6	6 Nm (4.4 lbf ft)	Loctite® 243™
Screw, voltage regulator	M6	6 Nm (4.4 lbf ft)	–
Screw, wheel speed sensor, front	M6	10 Nm (7.4 lbf ft)	–
Screw, wheel speed sensor, rear	M6	10 Nm (7.4 lbf ft)	–
Remaining chassis nuts	M8	25 Nm (18.4 lbf ft)	–
Remaining chassis screws	M8	25 Nm (18.4 lbf ft)	–
Screw, bottom triple clamp	M8	12 Nm (8.9 lbf ft)	–
Screw, exhaust clamp	M8	25 Nm (18.4 lbf ft)	–
Screw, foot brake lever	M8	25 Nm (18.4 lbf ft)	Loctite® 243™
Screw, fork stub	M8	15 Nm (11.1 lbf ft)	–
Screw, front footrest bracket	M8	25 Nm (18.4 lbf ft)	Loctite® 243™
Screw, fuel tank	M8	15 Nm (11.1 lbf ft)	–
Screw, handlebar clamp	M8	20 Nm (14.8 lbf ft)	–
Screw, ignition lock (tamper-proof screw)	M8	25 Nm (18.4 lbf ft)	Loctite® 243™
Screw, rear footrest bracket	M8	25 Nm (18.4 lbf ft)	Loctite® 243™
Screw, steering damper	M8	25 Nm (18.4 lbf ft)	Loctite® 243™
Screw, steering damper clamp	M8	12 Nm (8.9 lbf ft)	–
Screw, suitcase hook	M8	20 Nm (14.8 lbf ft)	Loctite® 243™
Screw, top triple clamp	M8	20 Nm (14.8 lbf ft)	–
Engine carrying screw	M10	45 Nm (33.2 lbf ft)	–
Remaining chassis nuts	M10	45 Nm (33.2 lbf ft)	–
Remaining chassis screws	M10	45 Nm (33.2 lbf ft)	–
Screw, front brake caliper	M10	45 Nm (33.2 lbf ft)	Loctite® 243™
Screw, handlebar support	M10	40 Nm (29.5 lbf ft)	Loctite® 243™
Screw, side stand	M10	35 Nm (25.8 lbf ft)	Loctite® 243™
Screw, side stand bracket	M10	45 Nm (33.2 lbf ft)	Loctite® 243™
Banjo bolt, brake line	M10x1	25 Nm (18.4 lbf ft)	–
Lambda sensor	M12x1.25	25 Nm (18.4 lbf ft)	–
Screw, bottom shock absorber	M14x1.5	80 Nm (59 lbf ft)	Thread greased
Screw, top shock absorber	M14x1.5	80 Nm (59 lbf ft)	Thread greased
Nut, socket	M18x1	4 Nm (3 lbf ft)	–

Nut, swingarm pivot	M19x1.5	130 Nm (95.9 lbf ft)	Thread greased
Screw, steering head, top	M22x1.5	50 Nm (36.9 lbf ft)	–
Screw, steering head, top	M22x1.5	46.5 Nm (34.3 lbf ft)	Only applies when using: Holding wrench for steering head bearing (45229050000) (  p. 343)
Nut, rear wheel spindle	M25x1.5	90 Nm (66.4 lbf ft)	Thread greased
Screw, front wheel spindle	M25x1.5	45 Nm (33.2 lbf ft)	Thread greased
Nut, steering head, top	M28x1.0	Step 1 10 Nm (7.4 lbf ft) Step 2 (loosen, counter- clockwise) 60°	–

## 28.1 Cleaning motorcycle

### Note

**Material damage** Components become damaged or destroyed if a pressure cleaner is used incorrectly. The high pressure forces water into the electrical components, connectors, throttle cables, and bearings, etc. Pressure which is too high causes malfunctions and destroys components.

- Do not direct the water jet directly on to electrical components, connectors, throttle cables or bearings.
- Maintain a minimum distance between the nozzle of the pressure cleaner and the component.  
Minimum clearance 60 cm (23.6 in)

### Warning

**Environmental hazard** Hazardous substances cause environmental damage.

- Dispose of oils, grease, filters, fuel, cleaning agents, brake fluid, etc., correctly and in compliance with the applicable regulations.

### Info

If you clean the motorcycle regularly, its value and appearance will be maintained over a long period. Avoid direct sunshine on the motorcycle during cleaning.

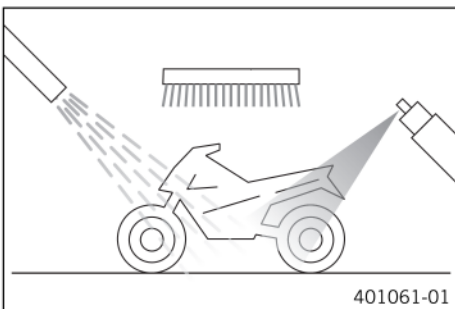

- Close off the exhaust system to keep water from entering.
- First remove coarse dirt particles with a gentle spray of water.
- Spray very dirty areas with a normal motorcycle cleaner and then clean with a brush.

Motorcycle cleaner (📖 p. 340)

### Info

Use warm water containing normal motorcycle cleaner and a soft sponge. Never apply motorcycle cleaner to a dry vehicle; always rinse the vehicle with water first. If the vehicle was operated in road salt, clean it with cold water. Warm water would enhance the corrosive effects of salt.

- After rinsing the motorcycle with a gentle spray of water, allow it to dry thoroughly.
- Remove the closure of the exhaust system.



### Warning

**Danger of accidents** Moisture and dirt impair the brake system.

- Brake carefully several times to dry out and remove dirt from the brake linings and the brake discs.

- After cleaning, ride the vehicle a short distance until the engine warms up.

### Info

The heat produced causes water at inaccessible locations in the engine and on the brake system to evaporate.

- Push back the protection caps of the handlebar controls to allow any water that has penetrated to evaporate.
- After the motorcycle has cooled off, lubricate all moving parts and bearings.
- Clean the chain. (📖 p. 117)
- Treat bare metal parts (except for brake discs and exhaust system) with corrosion inhibitor.

Preserving materials for paints, metal and rubber (📖 p. 340)

- Treat the painted parts with a mild paint polish.

Perfect Finish and high gloss polish for paints (📖 p. 340)

### Info

Do not polish plastic parts that are matte when the vehicle is delivered as this would seriously impair the material quality.

- Treat the plastic parts and powder-coated parts with a mild cleaning and care product.

Special cleaner for glossy and matte paint finishes, metal and plastic surfaces (📖 p. 341)

- Oil the ignition/steering lock, tank lock, and seat lock.

Universal oil spray (📖 p. 341)

## 28.2 Checks and maintenance steps for winter operation

### **i** Info

If you use the motorcycle in winter, you must expect salt on the roads. You should therefore take precautions against aggressive road salt.

If the vehicle was operated in road salt, clean it with cold water after riding. Warm water would enhance the corrosive effects of salt.

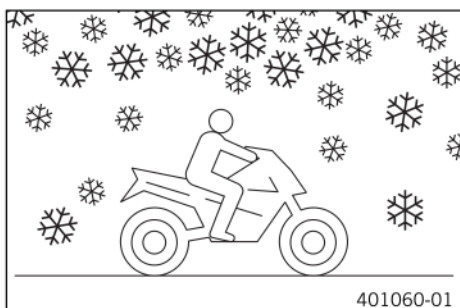

- Clean the motorcycle. (📖 p. 305)

- Clean the brakes.

### **i** Info

After **EVERY** trip on salted roads, thoroughly wash the brake calipers and brake linings with cold water and dry carefully. This should be done after the parts are cooled down and while they are installed.

After riding on salted roads, thoroughly wash the motorcycle with cold water and dry it well.

- Treat the engine, the swingarm, and all other bare or galvanized parts (except brake discs) with a wax-based corrosion inhibitor.

### **i** Info

Corrosion inhibitor must not come into contact with the brake discs. This would severely lower the braking effect.

- Clean the chain. (📖 p. 117)

## 29.1 Storage

### **i** Info

If you plan to garage the motorcycle for a longer period, perform the following steps or have them performed. Before storing the motorcycle, check all parts for function and wear. If service, repairs or replacements are necessary, you should do this during the storage period (less workshop overload). In this way, you can avoid long workshop waiting times at the start of the new season.

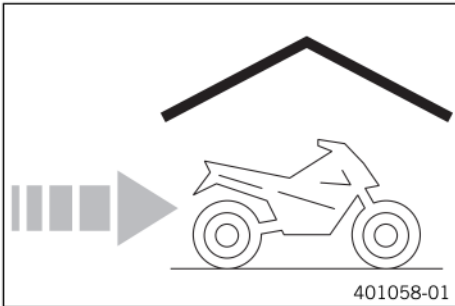

- When refueling for the last time before taking the motorcycle out of service, add fuel additive.

Fuel additive (📖 p. 340)
--------------------------

- Refuel.
- Clean the motorcycle. (📖 p. 305)
- Change the engine oil and filter, clean the oil screens. (📖 p. 276)
- Check the coolant fill level and antifreeze. (📖 p. 255)
- Check the tire air pressure. (📖 p. 97)
- Remove the battery. (📖 p. 125)

#### Guideline

Storage temperature of battery without direct sunshine	0... 35 °C (32... 95 °F)
--	--------------------------

- Recharge the battery.
- Store the vehicle in a dry location that is not subject to large fluctuations in temperature.
- Raise the vehicle with the center stand. (📖 p. 12)
- Cover the vehicle with a tarp or similar cover that is permeable to air.

### **i** Info

Do not use non-porous materials since they prevent humidity from escaping, thus causing corrosion.

Avoid running the engine for a short time only. Since the engine cannot warm up properly, the water vapor produced during combustion condenses and causes valves and the exhaust system to rust.

## 29.2 Preparing for use after storage

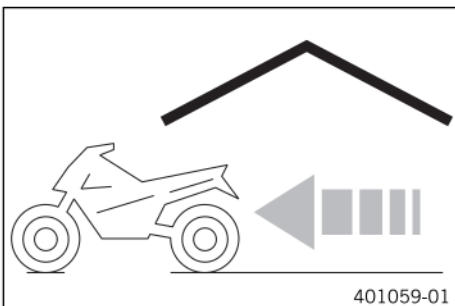

- Remove the vehicle from the center stand. (📖 p. 12)
- Install the battery. (📖 p. 125)

### **i** Info

If the battery was removed, the time and date must be set.

- Perform checks and maintenance measures when preparing for use. (📖 p. 307)
- Take a test ride.

## 29.3 Checks and maintenance measures when preparing for use

### **i** Info

Before every trip, check the condition of the vehicle and ensure that it is roadworthy. The vehicle must be in perfect technical condition when it is being operated.

- Check the engine oil level. (📖 p. 276)
- Check the brake fluid level of the front brake. (📖 p. 136)
- Check the rear brake fluid level. (📖 p. 142)
- Check the front brake linings. (📖 p. 134)
- Check the rear brake linings. (📖 p. 139)

- Check that the brake system is functioning properly.
- Check the coolant level in the compensating tank. (📖 p. 254)
- Check the chain for dirt.
- Check the chain tension. (📖 p. 115)
- Check the tire condition. (📖 p. 97)
- Check the tire air pressure. (📖 p. 97)
- Check the spoke tension. (📖 p. 99)
- Check the settings of all controls and ensure that they can be operated smoothly.
- Check that the electrical equipment is functioning properly.
- Check that baggage is correctly secured.
- Check the setting of the rear mirror.
- Check the fuel level.

## 30.1 Additional information

Any further work that results from the required work or from the recommended work must be ordered separately and invoiced separately.

## 30.2 Required work

	Every two years				
	Every year				
	every 30,000 km (18,600 mi)				
	every 15,000 km (9,300 mi)				
	after 1,000 km (620 mi)				
Read out the trouble code memory using the KTM diagnostics tool.	○	●	●	●	●
Check the fuel pressure. (🔧 p. 76)		●	●	●	●
Check the function of the electrical system.	○	●	●	●	●
Change the engine oil and filter, clean the oil screens. (🔧 p. 276)	○	●	●	●	●
Check the brake discs. (🔧 p. 106)	○	●	●	●	●
Check the front brake linings. (🔧 p. 134)	○	●	●	●	●
Check the rear brake linings. (🔧 p. 139)	○	●	●	●	●
Retighten the spokes.	○				
Check the spoke tension. (🔧 p. 99)		●	●	●	●
Check the rim run-out. (🔧 p. 98)	○	●	●	●	●
Check the tire condition. (🔧 p. 97)	○	●	●	●	●
Check the tire air pressure. (🔧 p. 97)	○	●	●	●	●
Check the rear brake fluid level. (🔧 p. 142)	○	●	●	●	
Check the shock absorber and fork for leaks. Perform service as needed and depending on how the vehicle is used.	○	●	●	●	●
Clean the dust boots of the fork legs. (🔧 p. 14)		●	●		
Check the chain, rear sprocket and engine sprocket. (🔧 p. 116)		●	●	●	●
Check the chain tension. (🔧 p. 115)	○	●	●	●	●
Check the brake lines for damage and leakage.	○	●	●	●	●
Check the brake fluid level of the front brake. (🔧 p. 136)	○	●	●	●	
Check the coolant level in the compensating tank. (🔧 p. 254)	○	●	●	●	●
Check that the radiator fan is functioning properly.	○	●	●	●	●
Change the air filter, clean the air filter box. (🔧 p. 66)		●	●		
Check the cables for damage and routing without sharp bends. (fuel tank removed)		●	●	●	●
Change the spark plugs (air filter removed). (🔧 p. 284)			●		
Check the valve clearance (air filter and spark plugs removed). (🔧 p. 267)			●		
Changing the SAS membrane. (🔧 p. 242)			●		
Change the front brake fluid. (🔧 p. 137)					●
Change the rear brake fluid. (🔧 p. 143)					●
Check the steering head bearing play. (🔧 p. 24)	○	●	●	●	●
Check the setting of the lighting system. (🔧 p. 148)	○	●	●		
Check the CO adjustment with the KTM diagnostics tool.	○	●	●		
Final check: Check the vehicle for roadworthiness and take a test ride.	○	●	●	●	●
Read out the error memory after the test ride using the KTM diagnostics tool.	○	●	●	●	●
Reset the service interval display.	○	●	●	●	●
Make the service entry in the <b>KTM Dealer.net</b> and in the Service and Warranty Booklet.	○	●	●	●	●

- One-time interval
- Periodic interval

## 30.3 Recommended work

	Every four years				
	Every two years		Every year		
	every 15,000 km (9,300 mi)				
	after 1,000 km (620 mi)				
Check/clean the oil nozzle for clutch lubrication. (🔧 p. 280)	○	●			
Checking the swingarm bearing for play. (🔧 p. 51)		●			
Check the wheel bearing for play. (🔧 p. 98)		●			
Grease all moving parts (e.g., side stand, hand lever, chain, ...) and check for smooth operation.	○	●	●	●	●
Empty the drainage hoses. (Super Adventure US/CN)	○	●	●	●	●
Check all hoses (e.g. fuel, cooling, bleeder, drainage, etc.) and sleeves for cracking, leaks, and incorrect routing.		●	●	●	●
Check the antifreeze.	○	●	●	●	●
Check/rectify the fluid level of the hydraulic clutch. (🔧 p. 244)		●	●		
Change the hydraulic clutch fluid. (🔧 p. 244)				●	●
Check the screws and nuts for tightness.	○	●	●	●	●
Change the coolant.					●

- One-time interval
- Periodic interval





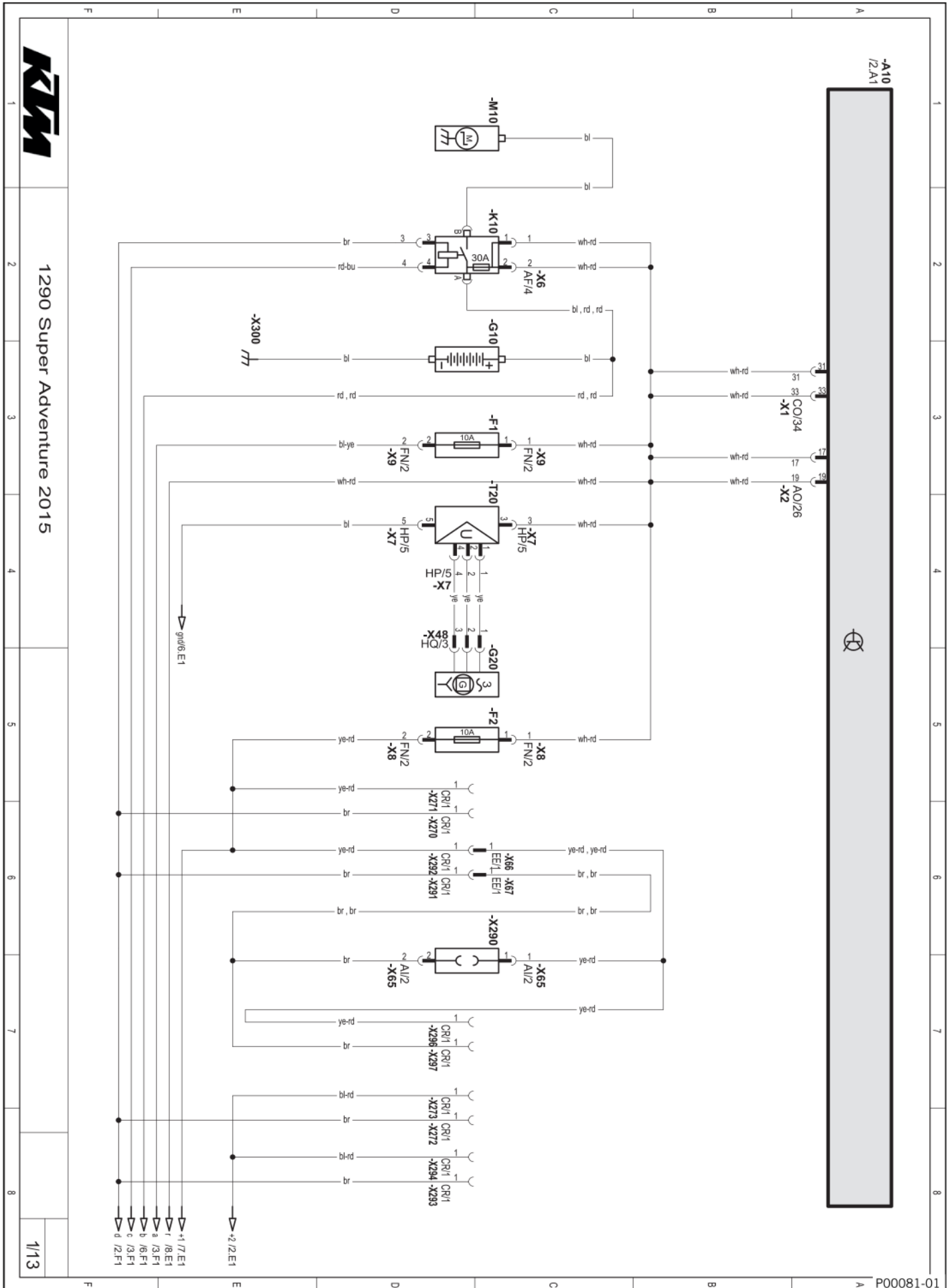

**Components:**

A10	Central electronics control unit
F1	Fuse
F2	Fuse
G10	Battery
G20	Alternator
K10	Starter relay with main fuse
M10	Starter motor
T20	Voltage regulator
X270	Connector for accessory ground (terminal 31) <b>ACC 1</b> (not assigned)
X271	Connector for accessory plus (terminal 30) <b>ACC 1</b> (not assigned)
X272	Connector for accessory ground (terminal 31) <b>ACC 2</b> (not assigned)
X273	Connector for accessory plus (terminal 15) <b>ACC 2</b> (not assigned)
X290	Socket
X291	Connector for accessory ground (terminal 31) <b>ACC 1</b>
X292	Connector for accessory plus (terminal 30) <b>ACC 1</b>
X293	Connector for accessory ground (terminal 31) <b>ACC 2</b> (not assigned)
X294	Connector for accessory plus (terminal 15) <b>ACC 2</b> (not assigned)
X296	Connector for accessory plus (terminal 30) <b>ACC 1</b> (not assigned)
X297	Connector for accessory ground (terminal 31) <b>ACC 1</b> (not assigned)

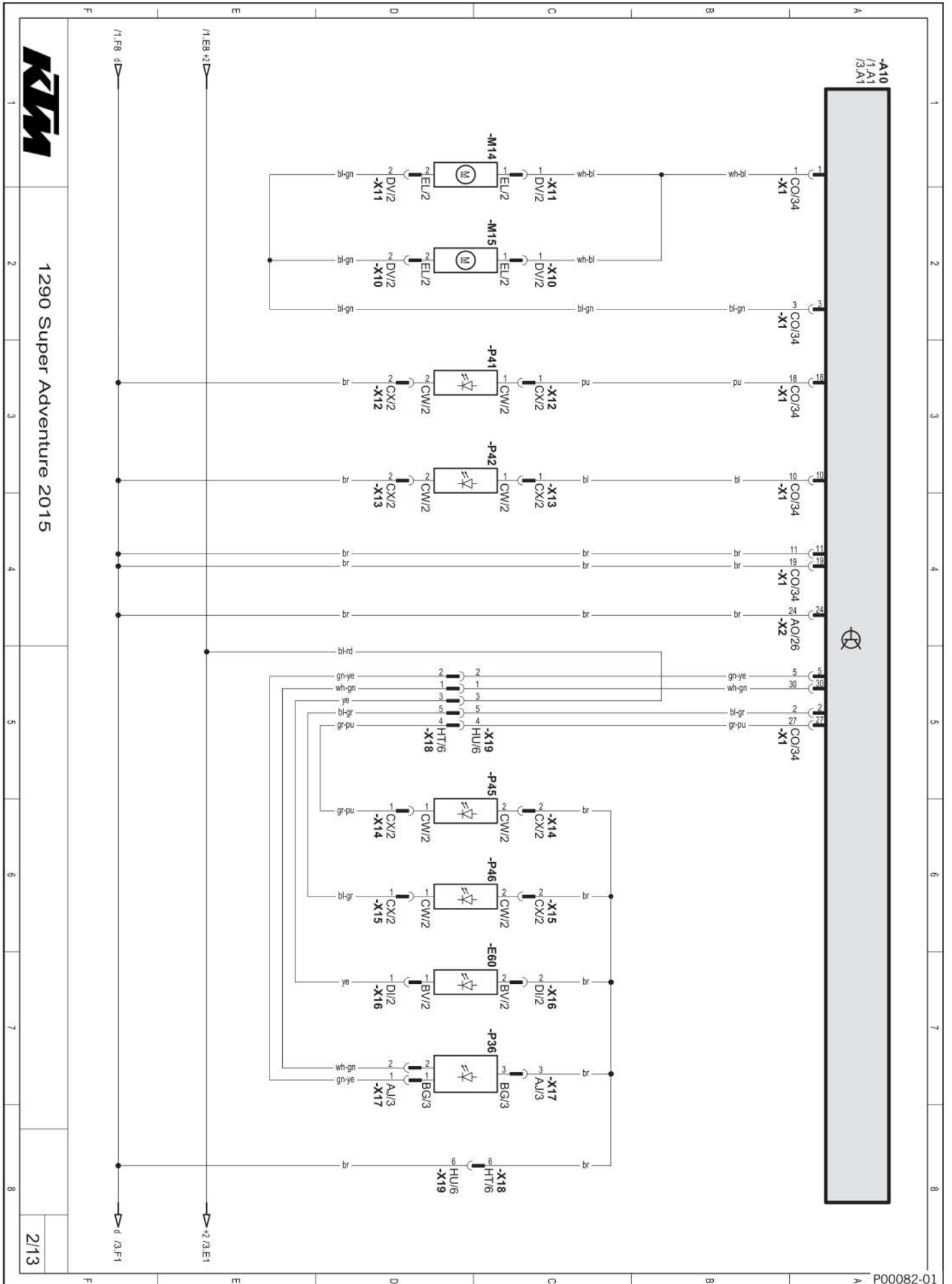

**Components:**

A10	Central electronics control unit
E60	License plate lamp
M14	Radiator fan 1
M15	Radiator fan 2
P36	Tail light/brake light
P41	Front left turn signal
P42	Front right turn signal
P45	Rear left turn signal
P46	Rear right turn signal

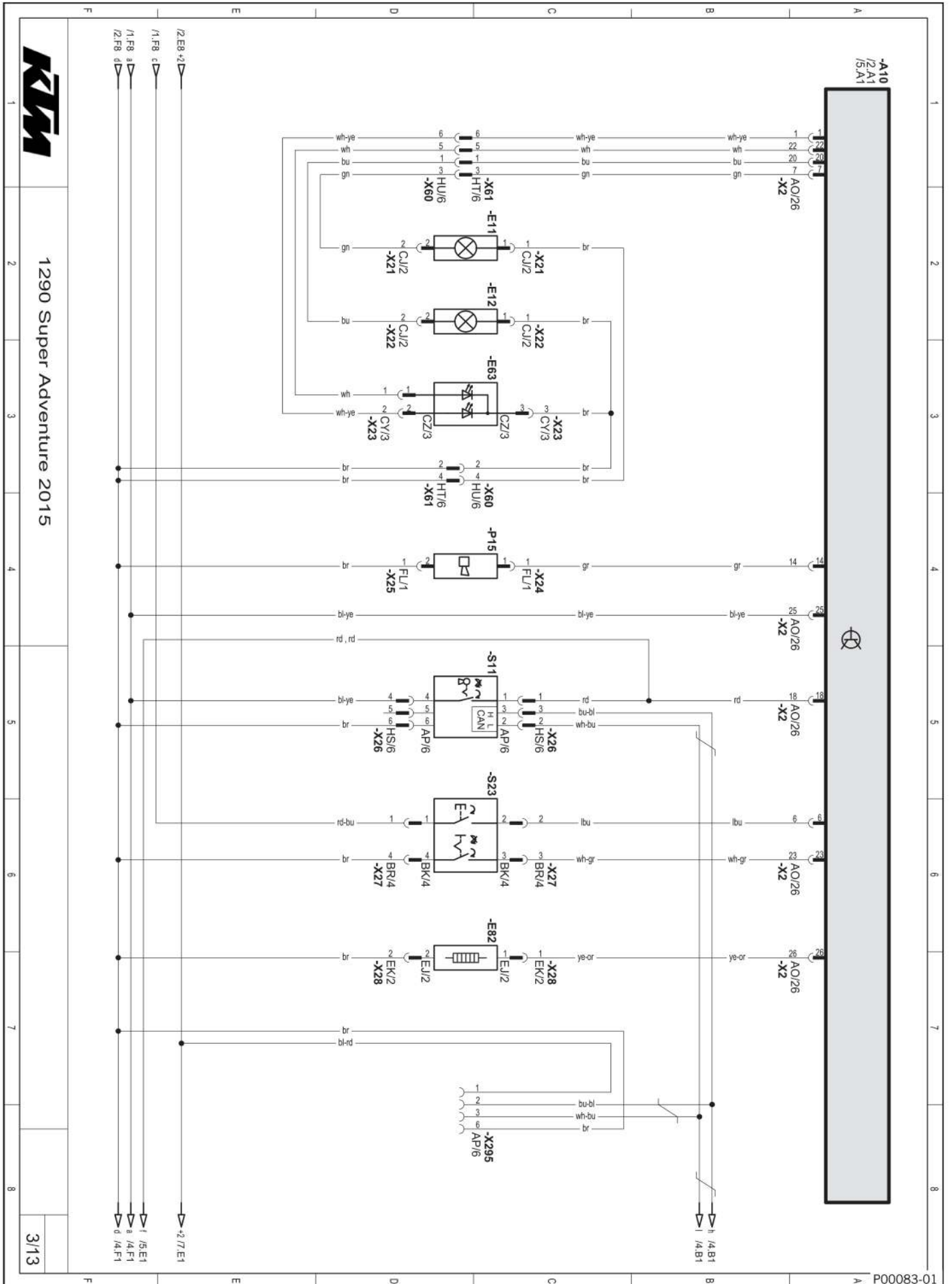

1290 Super Adventure 2015

**Components:**

A10	Central electronics control unit
E11	Low beam
E12	High beam
E63	Parking light, daytime running light
P15	Horn
S11	Ignition/handlebar lock, immobilizer control unit
S23	Emergency OFF switch, electric starter button
E82	Heated grips
X295	Diagnostics connector

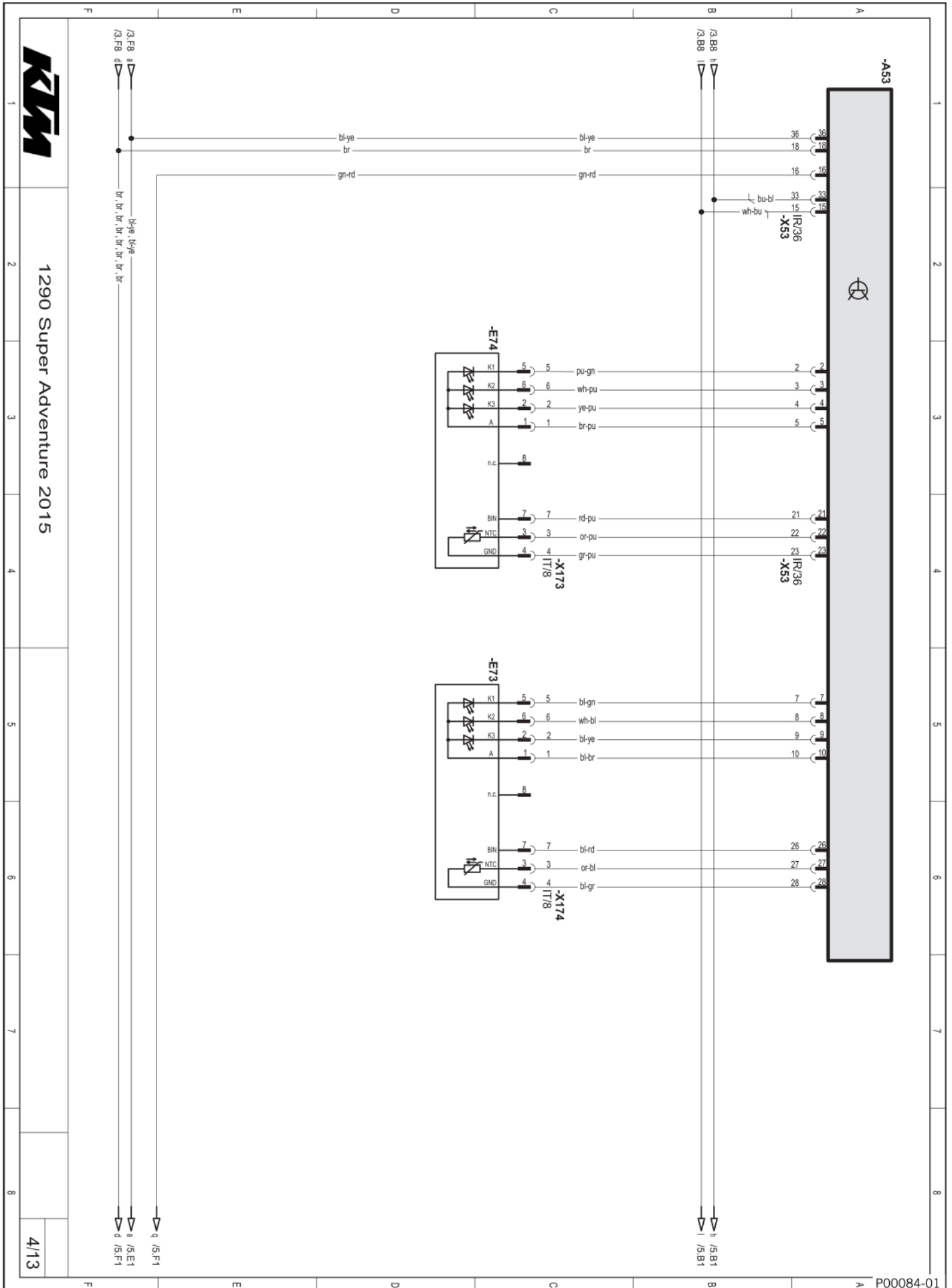



**Components:**

A53	Light control unit
E73	Cornering light right
E74	Cornering light left



**Components:**

A10	Central electronics control unit
A50	Alarm system (optional)
B25	Ambient air temperature sensor
B36	Alarm system switch (optional)
B85	Tire pressure monitoring
B86	Angle sensor
P10	Combination instrument
S32	Combination steering switch

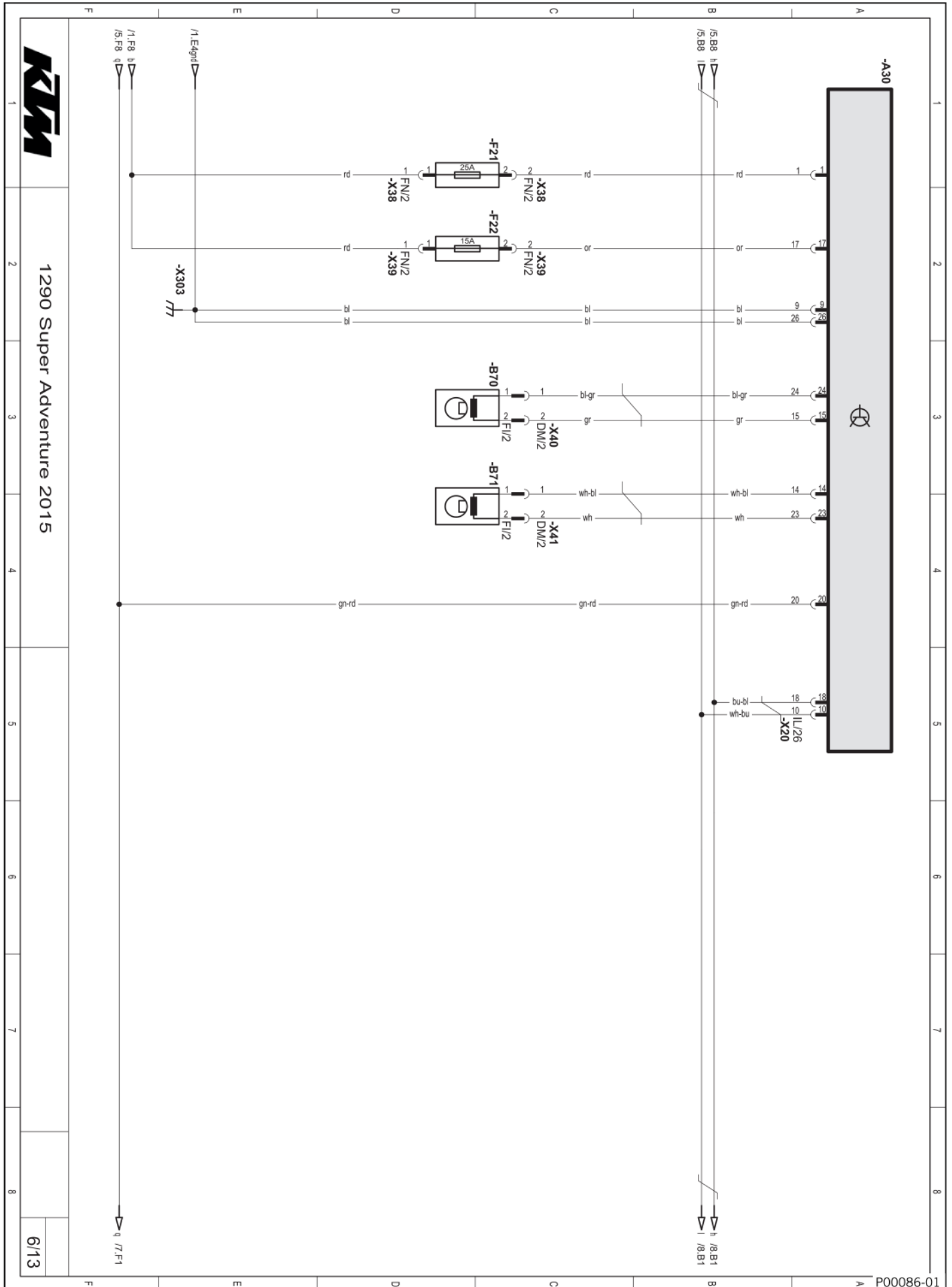

**Components:**

A30	ABS control unit
B70	Front wheel speed sensor
B71	Wheel speed sensor, rear
F21	ABS fuse
F22	ABS fuse

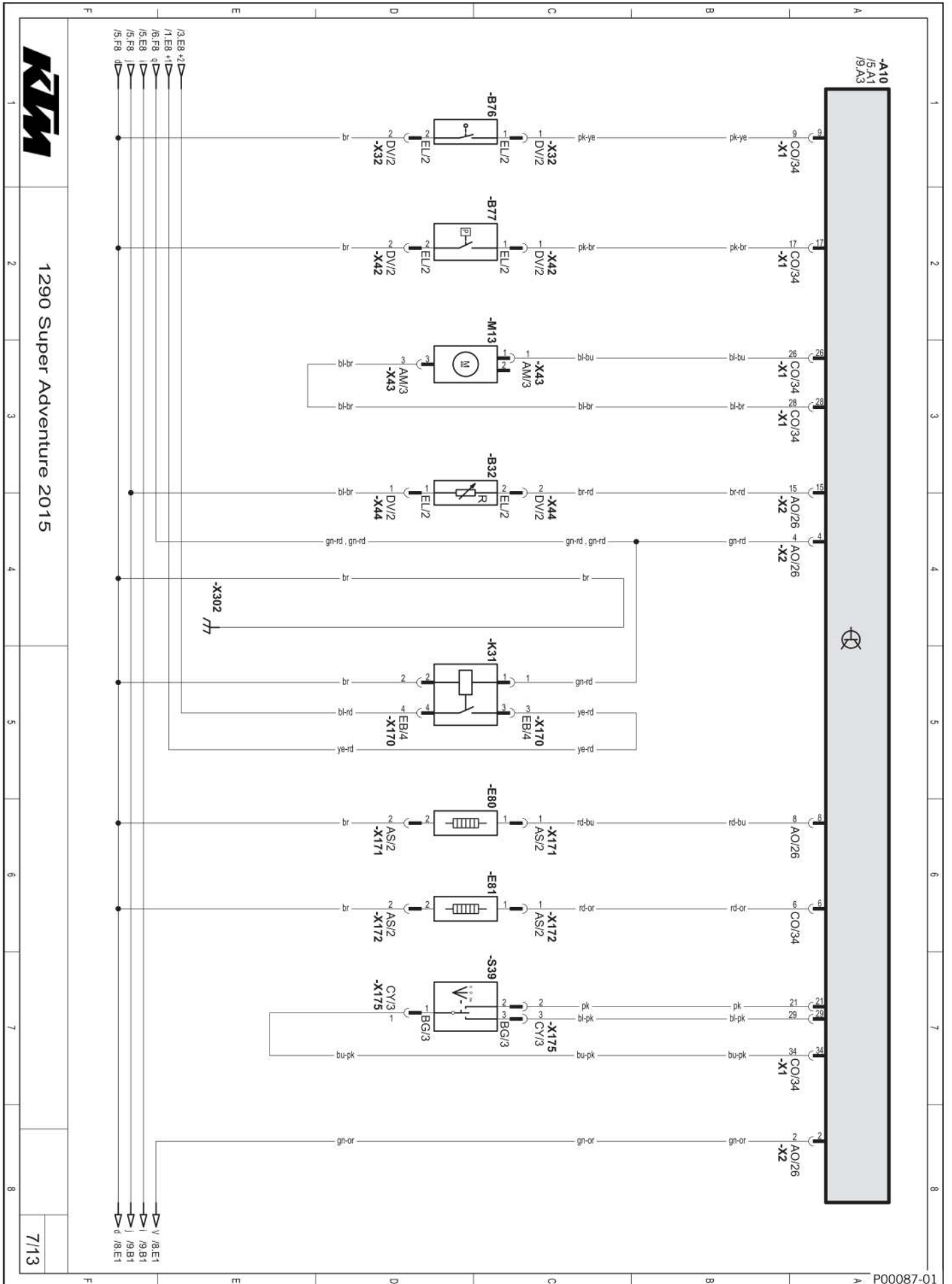

**Components:**

A10	Central electronics control unit
B32	Fuel level sensor
B76	Front brake light switch
B77	Rear brake light switch
M13	Fuel pump
E80	Front seat heating
E81	Rear seat heating
K31	ACC2 relay
S39	Rear seat heating switch

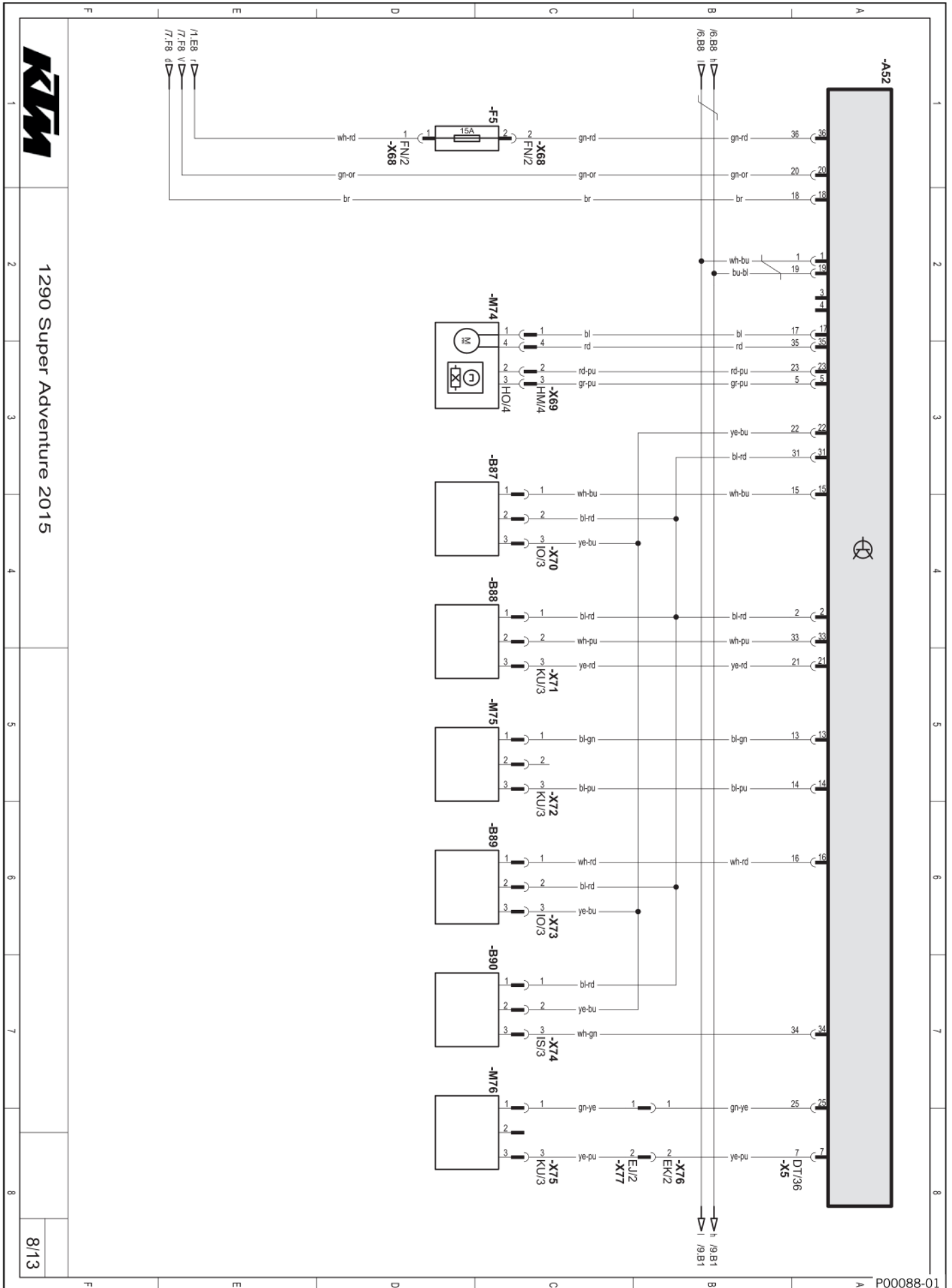



**Components:**

A52	SCU control unit
B87	Front acceleration sensor
B88	Suspension travel sensor
B89	Rear acceleration sensor
B90	Swing angle sensor
F5	Fuse
M74	Spring preload control motor with hall sensor
M75	Front damping valve
M76	Rear damping valve

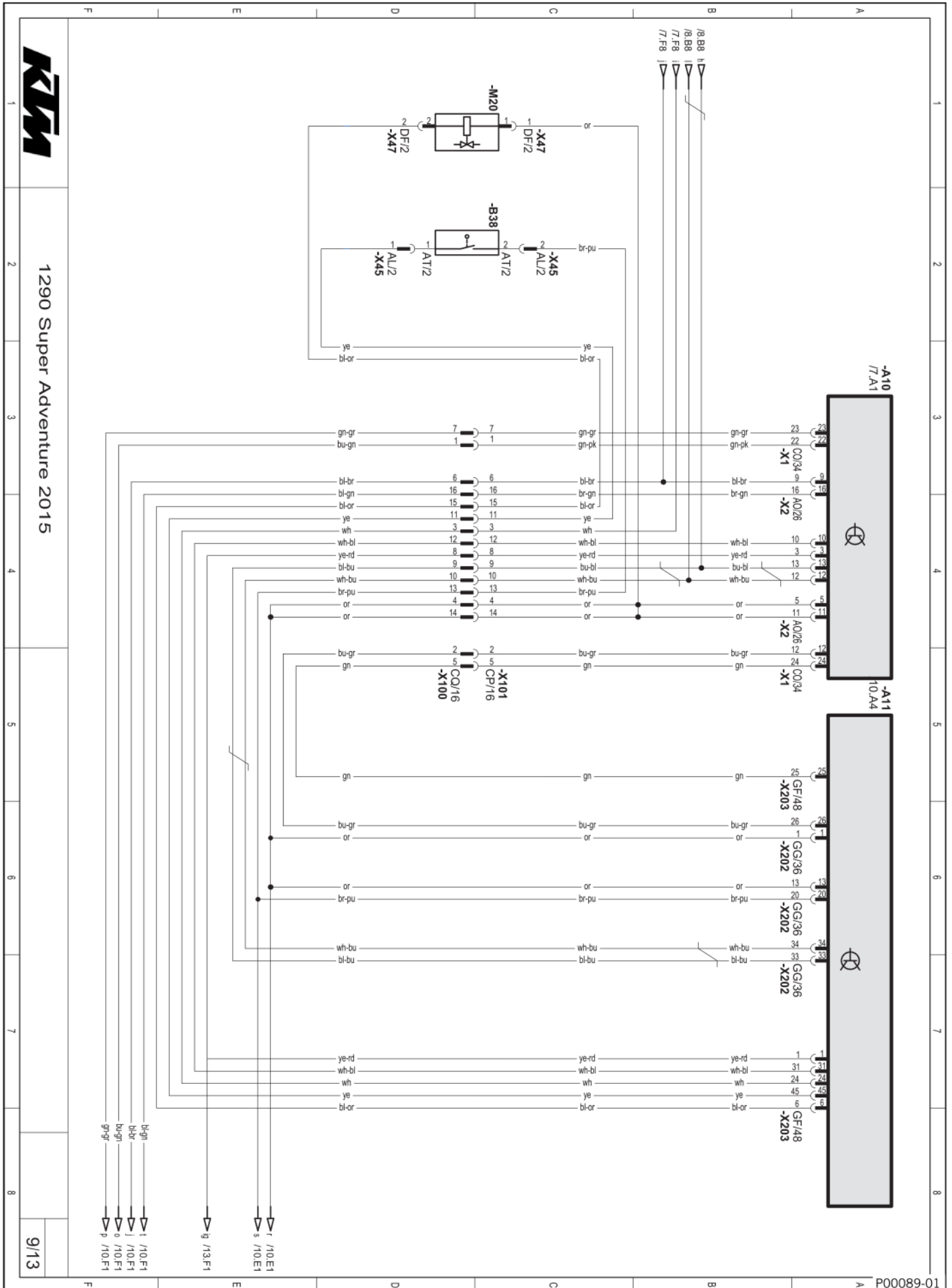

**Components:**

A10	Central electronics control unit
A11	Engine electronics control unit
B38	Clutch switch
M20	Fuel evaporation valve (optional)

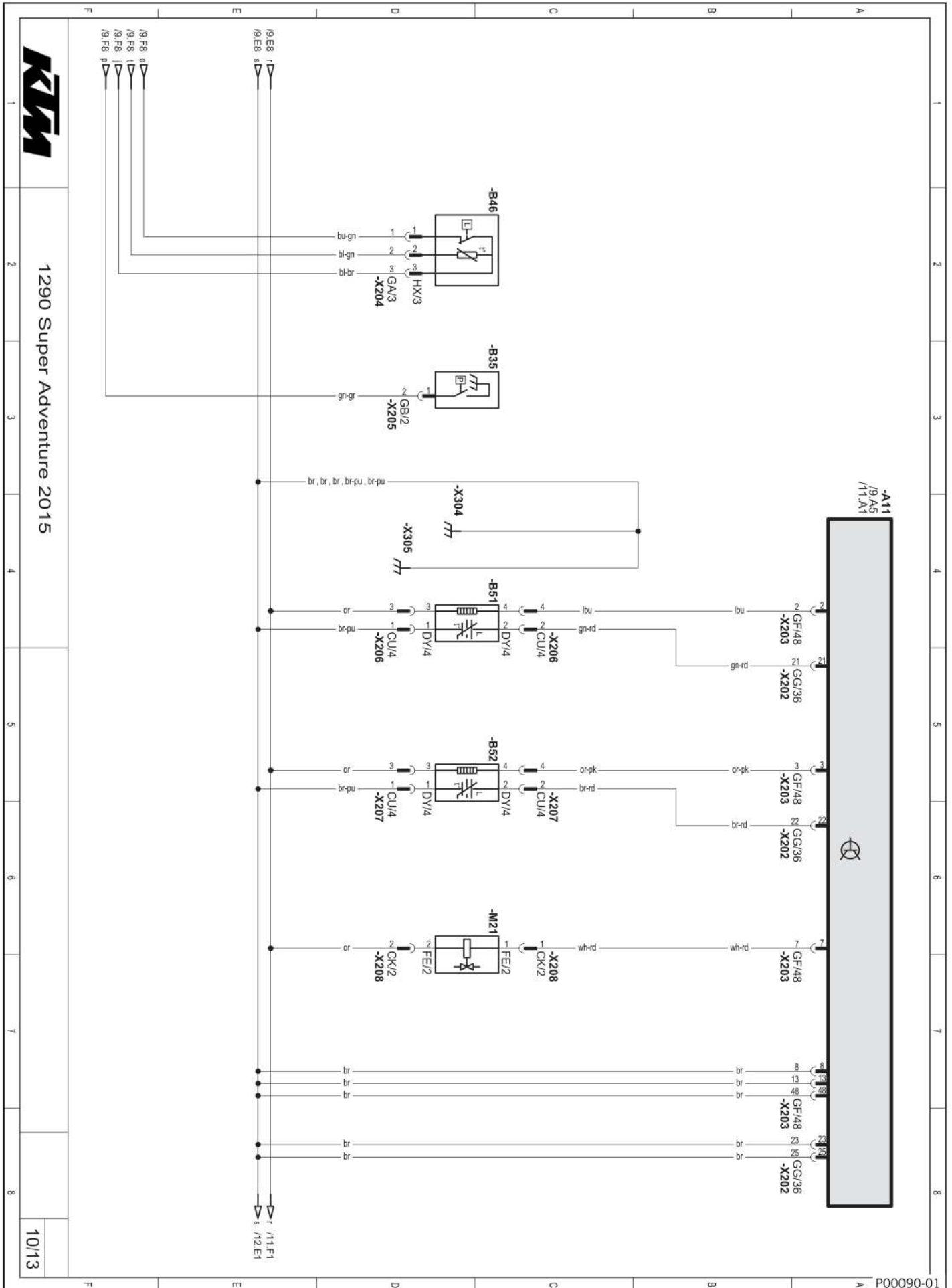

1290 Super Adventure 2015

**Components:**

A11	Engine electronics control unit
B35	Oil pressure sensor
B46	Oil temperature/oil level sensor
B51	Lambda sensor, cylinder 1
B52	Lambda sensor, cylinder 2
M21	Secondary air valve

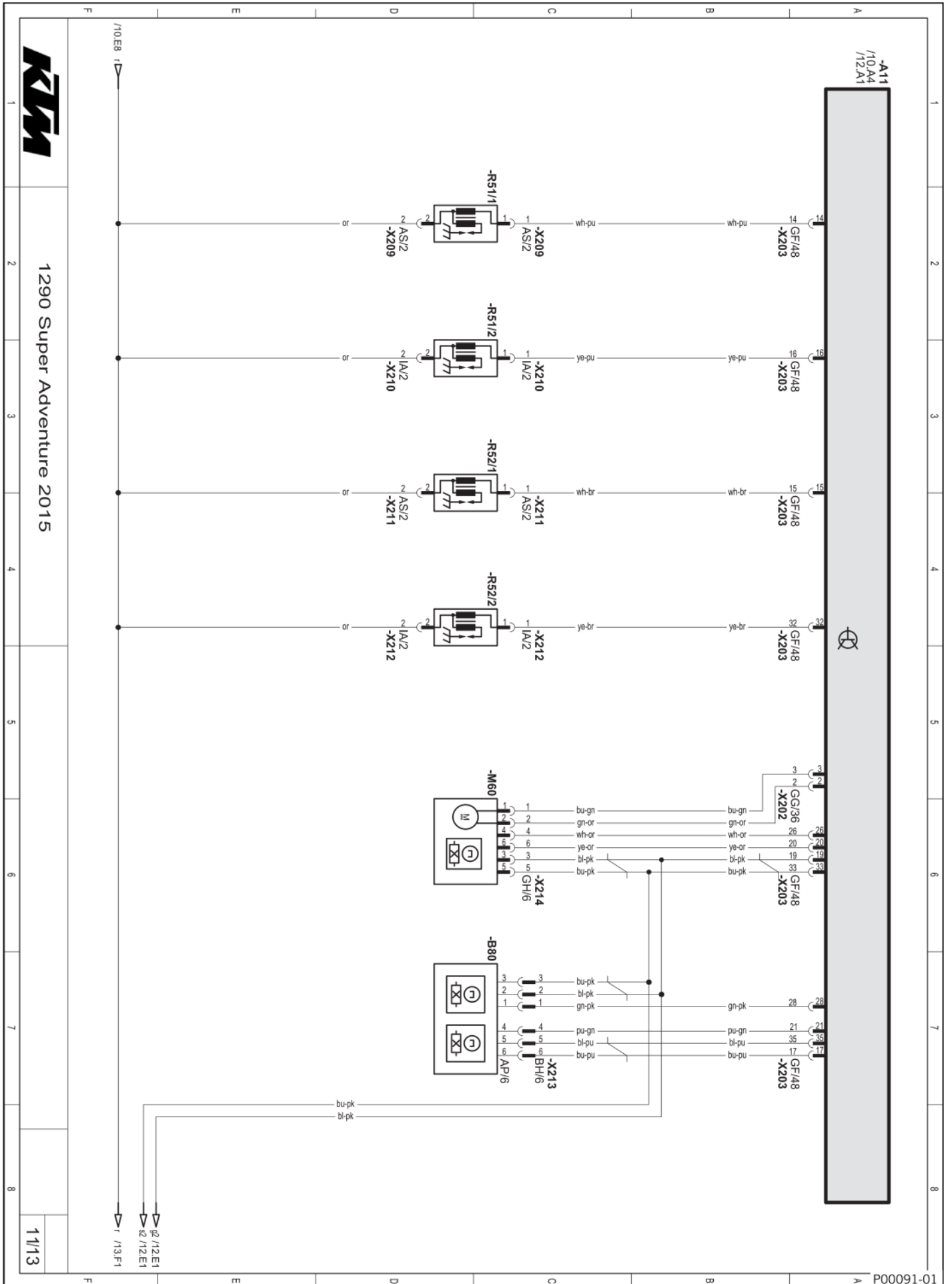

**Components:**

A11	Engine electronics control unit
B80	Accelerator position sensor circuit A/B
M60	Throttle stepper motor/throttle position sensor circuit A/B
R51/1	Ignition coil 1, cylinder 1
R51/2	Ignition coil 2, cylinder 1
R52/1	Ignition coil 1, cylinder 2
R52/2	Ignition coil 2, cylinder 2

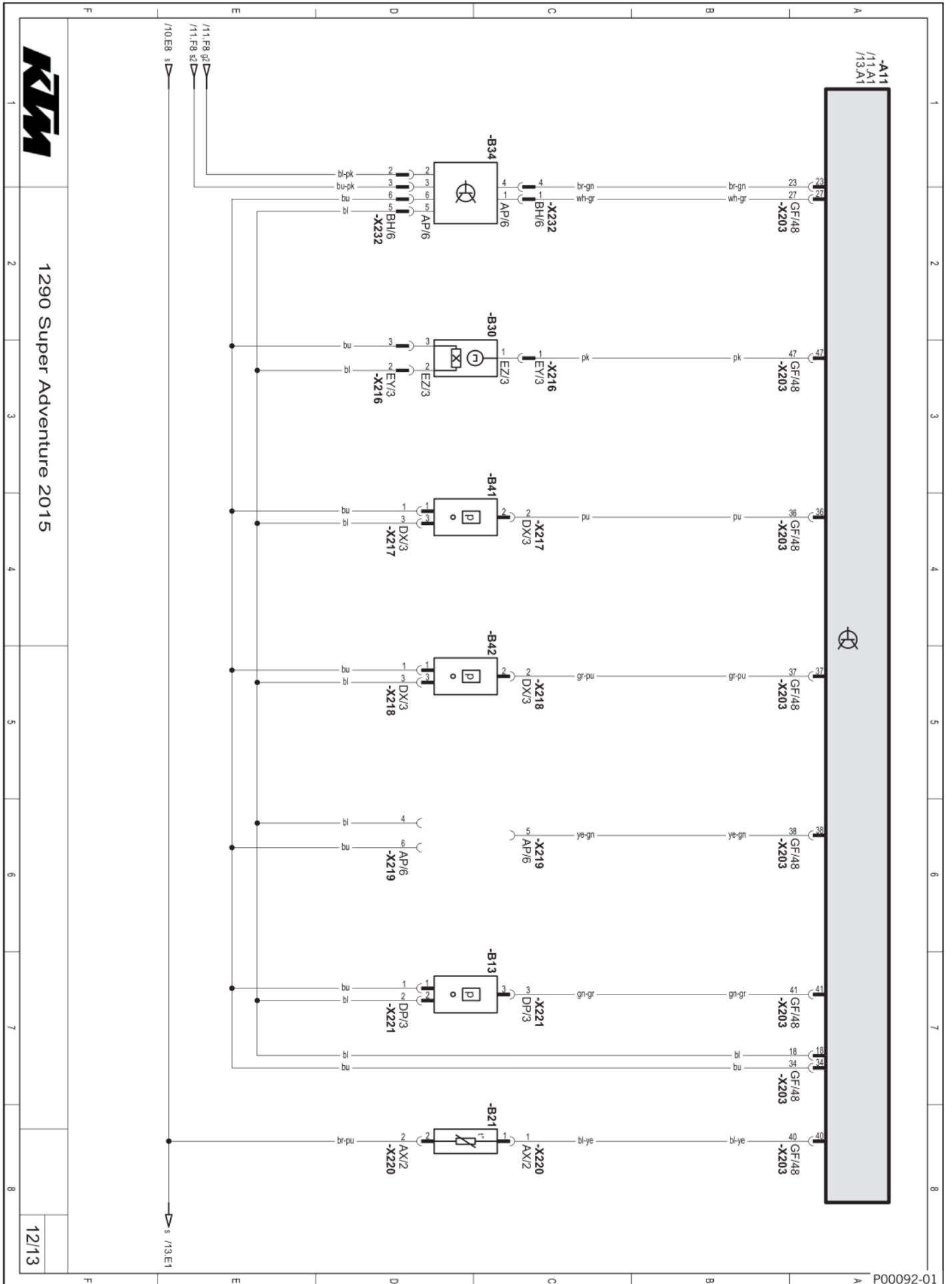

1290 Super Adventure 2015

12/13



**Components:**

A11	Engine electronics control unit
B13	Ambient air pressure sensor
B21	Coolant temperature sensor, cylinder 1
B30	Side stand switch
B34	Gear position sensor
B41	Manifold absolute pressure sensor cylinder 1
B42	Manifold absolute pressure sensor cylinder 2

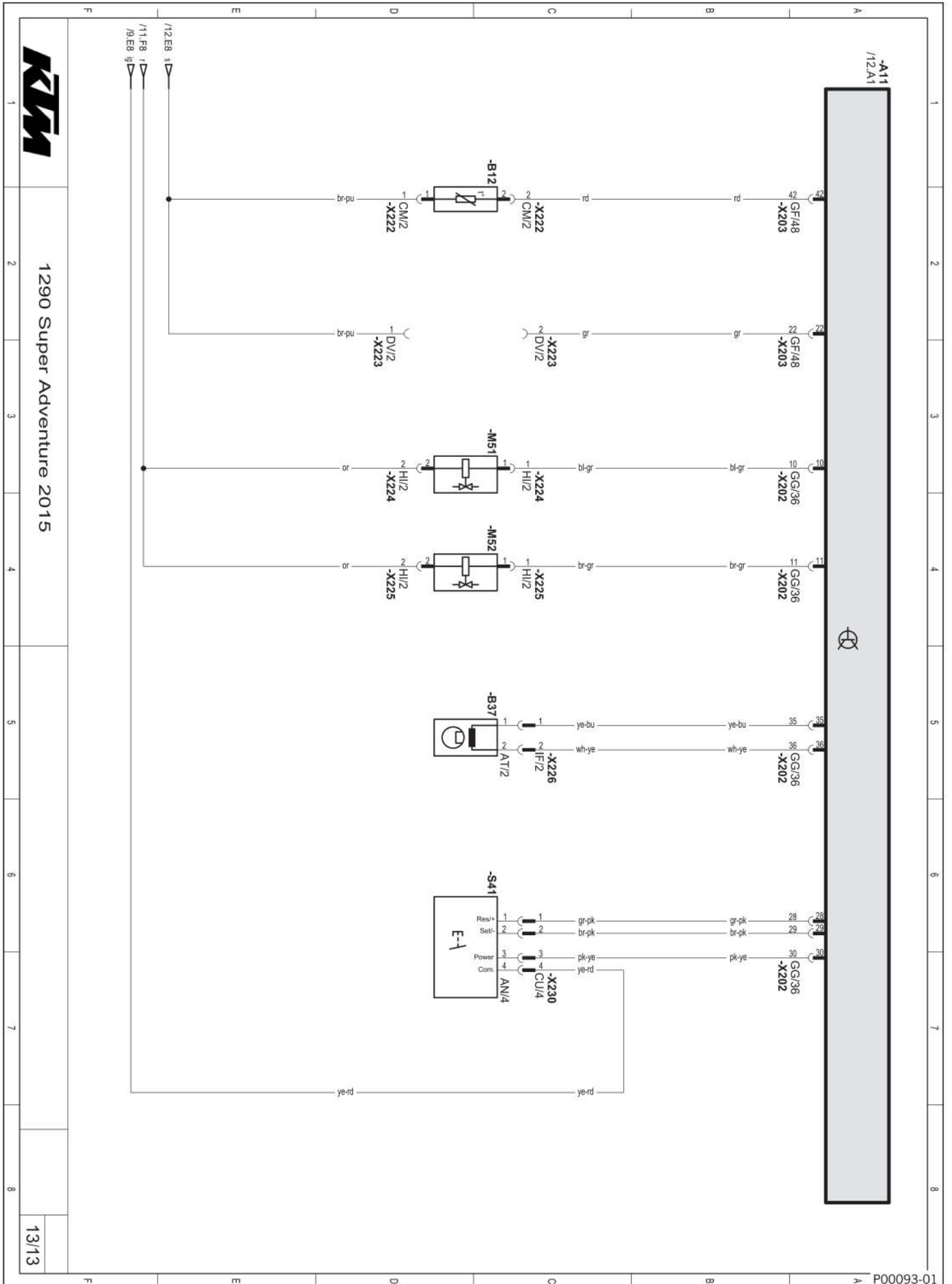

**Components:**

A11	Engine electronics control unit
B12	Intake air temperature sensor
B37	Crankshaft position sensor
M51	Injection valve cylinder 1
M52	Injection valve cylinder 2
S41	Switch/tip switch for the cruise control system

**Cable colors:**

bl	Black
br	Brown
bu	Blue
gn	Green
gr	Gray
lbu	Light blue
or	Orange
pk	Pink
pu	Violet
rd	Red
wh	White
ye	Yellow

## Brake fluid DOT 4 / DOT 5.1

**Standard/classification**

- DOT

**Guideline**

- Use only brake fluid that complies with the specified standard (see specifications on the container) and that exhibits the corresponding properties.

**Recommended supplier**

**Castrol**

- REACT PERFORMANCE DOT 4

**Motorex®**

- Brake Fluid DOT 5.1

## Coolant

**Guideline**

- Only use high-grade, silicate-free coolant with corrosion inhibitor additive for aluminum motors. Low grade and unsuitable antifreeze causes corrosion, deposits and frothing.
- Do not use pure water as only coolant is able to meet the requirements needed in terms of corrosion protection and lubrication properties.
- Only use coolant that complies with the requirements stated (see specifications on the container) and that has the relevant properties.

Antifreeze protection to at least	-25 °C (-13 °F)
-----------------------------------	-----------------

The mixture ratio must be adjusted to the necessary antifreeze protection. Use distilled water if the coolant needs to be diluted.

The use of premixed coolant is recommended.

Observe the coolant manufacturer specifications for antifreeze protection, dilution and miscibility (compatibility) with other coolants.

**Recommended supplier**

**Motorex®**

- COOLANT M3.0

## Engine oil (SAE 10W/50)

**Standard/classification**

- JASO T903 MA (p. 358)
- SAE (p. 358) (SAE 10W/50)

**Guideline**

- Use only engine oils that comply with the specified standards (see specifications on the container) and that possess the corresponding properties.

Fully synthetic engine oil
----------------------------

**Recommended supplier**

**Motorex®**

- Power Synt 4T

## Engine oil (SAE 5W/40)

**Standard/classification**

- JASO T903 MA (p. 358)
- SAE (p. 358) (SAE 5W/40)

**Guideline**

- Use only engine oils that comply with the specified standards (see specifications on the container) and that possess the corresponding properties.

Synthetic engine oil
----------------------

**Recommended supplier**

**Motorex®**

- Power Synt 4T

## Fork oil (SAE 4) (48601166S1)

### Standard/classification

- SAE (📄 p. 358) (SAE 4)

### Guideline

- Use only oils that comply with the specified standards (see specifications on the container) and that exhibit the corresponding properties.

## Hydraulic fluid (15)

### Standard/classification

- ISO VG (15)

### Guideline

- Use only hydraulic oil that complies with the specified standard (see specifications on the container) and that possesses the corresponding properties.

### Recommended supplier

#### Motorex®

- Hydraulic Fluid 75

## Super unleaded (ROZ 95/RON 95/PON 91)

### Standard/classification

- DIN EN 228 (ROZ 95/RON 95/PON 91)

### Guideline

- Only use unleaded super fuel that matches or is equivalent to the specified fuel grade.
- Fuel with an ethanol content of up to 10 % (E10 fuel) is safe to use.



### Info

Do **not** use fuel containing methanol (e. g. M15, M85, M100) or more than 10 % ethanol (e. g. E15, E25, E85, E100).

## Chain cleaner

Recommended supplier

Motorex®

- Chain Clean

## Chain lube for road use

Guideline

Recommended supplier

Motorex®

- Chainlube Road

## Fuel additive

Recommended supplier

Motorex®

- Fuel Stabilizer

## High viscosity grease

Recommended supplier

SKF®

- LGHB 2

## Long-life grease

Recommended supplier

Motorex®

- Bike Grease 2000

## Lubricant (T14034)

Recommended supplier

Fuchs

- Fuchs Renolit IPR 2

## Lubricant (T158)

Recommended supplier

Lubcon®

- Turmogrease® PP 300

## Motorcycle cleaner

Recommended supplier

Motorex®

- Moto Clean

## Perfect Finish and high gloss polish for paints

Recommended supplier

Motorex®

- Moto Polish & Shine

## Preserving materials for paints, metal and rubber

Recommended supplier

Motorex®

- Moto Protect

### Special cleaner for glossy and matte paint finishes, metal and plastic surfaces

Recommended supplier

Motorex®

- Quick Cleaner

### Universal oil spray

Recommended supplier

Motorex®

- Joker 440 Synthetic

## Bleeder cover

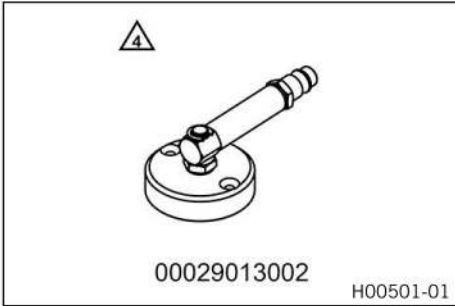

Art. no.: 00029013002

## Bleeder cover

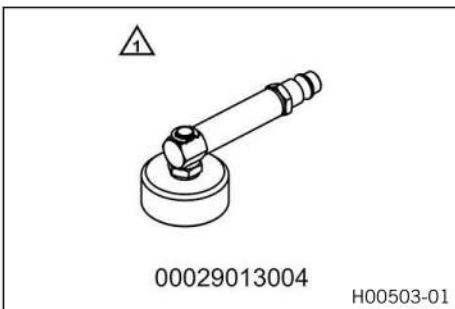

Art. no.: 00029013004

## Bleeding device

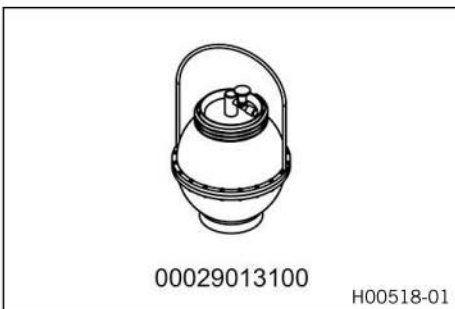

Art. no.: 00029013100

## Battery charger XCharge-professional EU

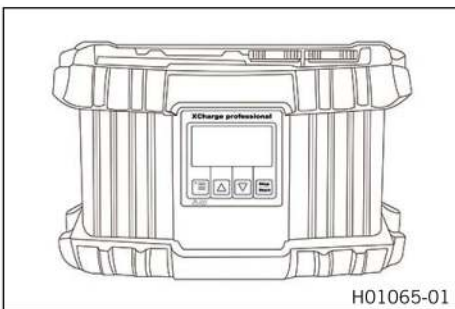

Art. no.: 00029095050

## Battery charger XCharge-professional US

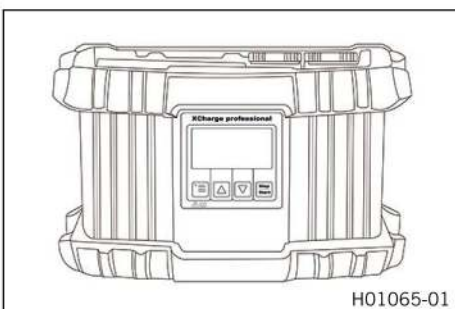

Art. no.: 00029095051



## Battery charger XCharge-professional GB

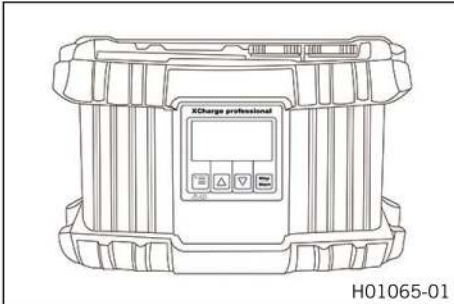

Art. no.: 00029095052

## Battery charger XCharge-professional CH

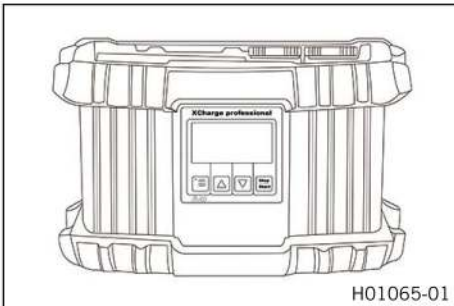

Art. no.: 00029095053

## Bearing puller

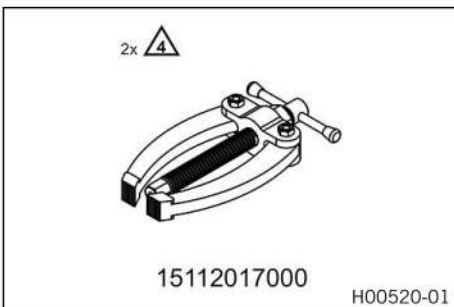

Art. no.: 15112017000

## Internal bearing puller

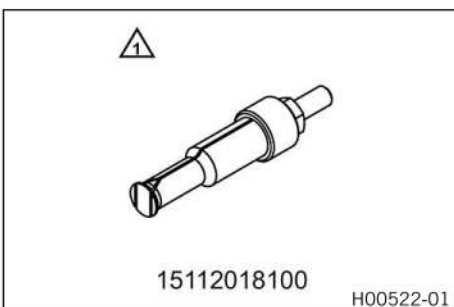

Art. no.: 15112018100

**Feature**

18... 23 mm (0.71... 0.91 in)

## Holding wrench for steering head bearing

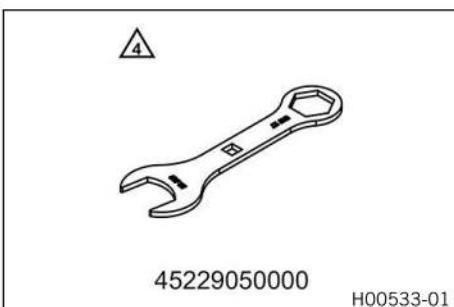

Art. no.: 45229050000

## Bleed syringe

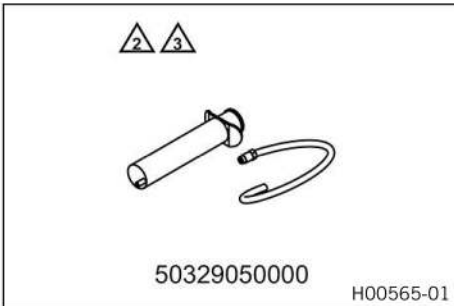

Art. no.: 50329050000

## Circlip pliers reverse

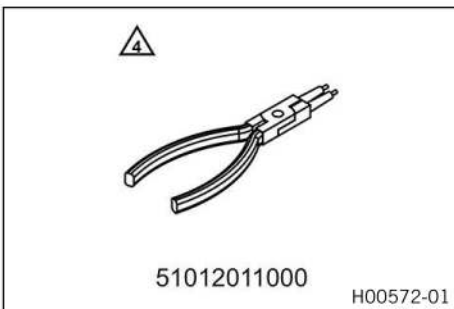

Art. no.: 51012011000

## Clutch holder

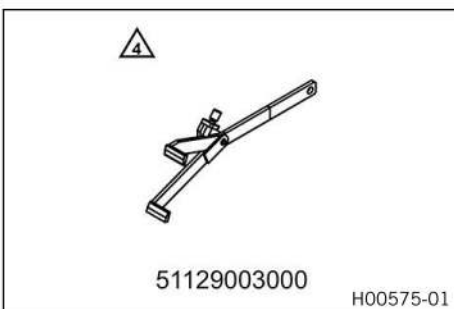

Art. no.: 51129003000

## Pliers for footrest spring

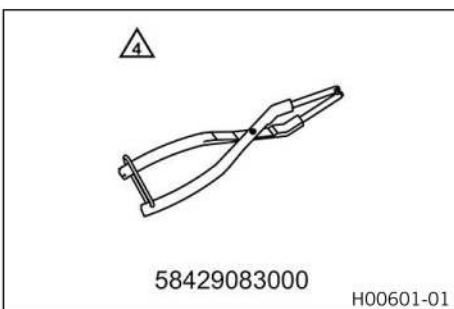

Art. no.: 58429083000

## Tool bracket

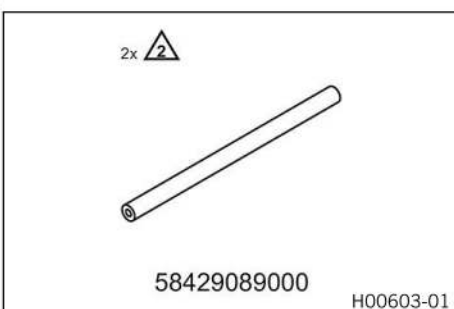

Art. no.: 58429089000

## Press-in tool

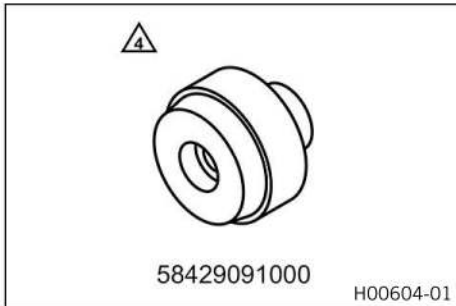

Art. no.: 58429091000

## Press-out tool



Art. no.: 58429092000

## Torque wrench with various accessories in set

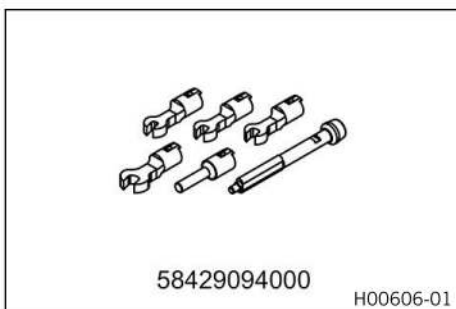

Art. no.: 58429094000

## Mount for torque wrench

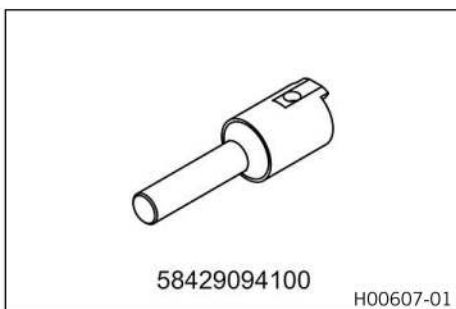

Art. no.: 58429094100

## Valve spring mounter

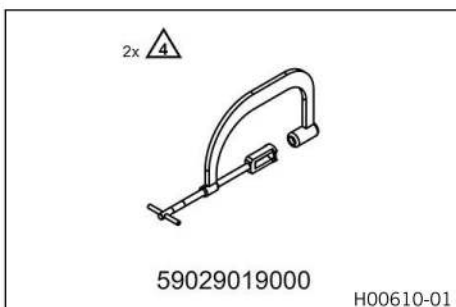

Art. no.: 59029019000

## Limit plug gauge

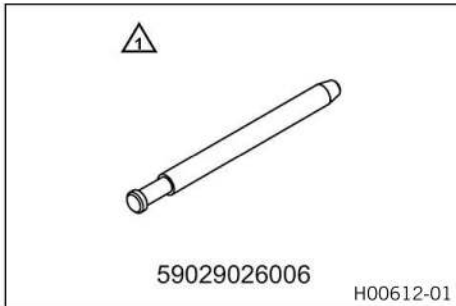

Art. no.: 59029026006

## Feeler gauge

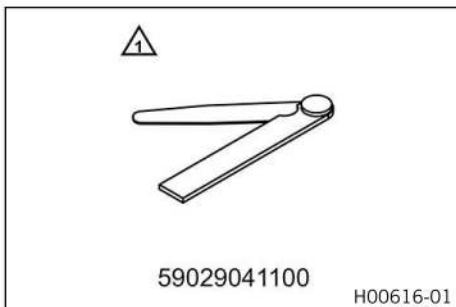

Art. no.: 59029041100

## Graduated disc

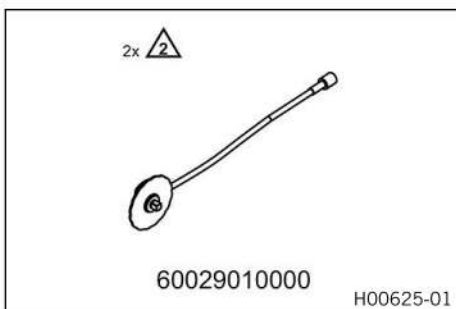

Art. no.: 60029010000

## Plastigauge clearance gauge

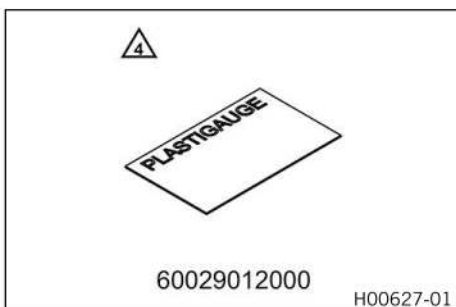

Art. no.: 60029012000

## Internal bearing puller

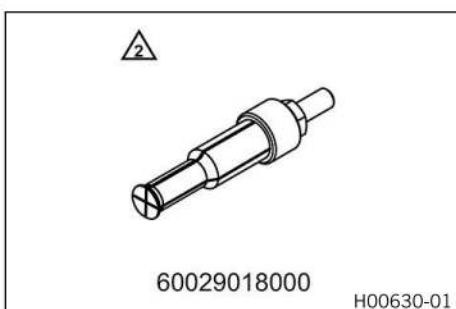

Art. no.: 60029018000

**Feature**

23... 28 mm (0.91... 1.1 in)

## Chain rivet tool

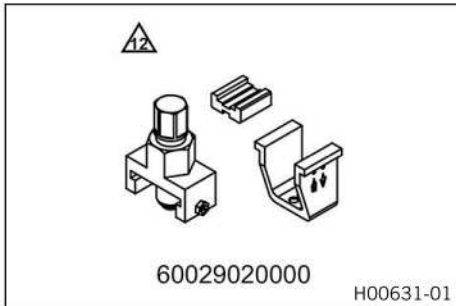

Art. no.: 60029020000

60029020000

H00631-01

## Step bearing tool

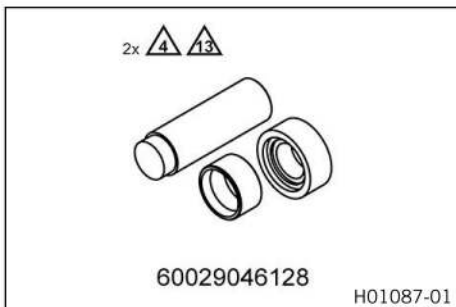

Art. no.: 60029046128

60029046128

H01087-01

## Pliers for spring band clamp

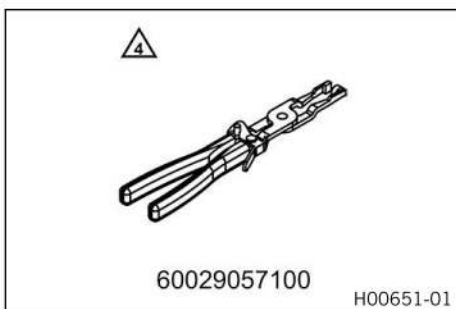

Art. no.: 60029057100

60029057100

H00651-01

## Multi-tooth wrench socket 10 mm; 1/2" drive

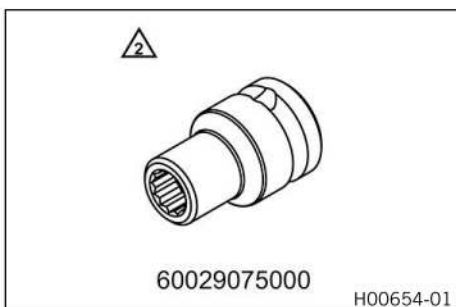

Art. no.: 60029075000

60029075000

H00654-01

## Testing hose

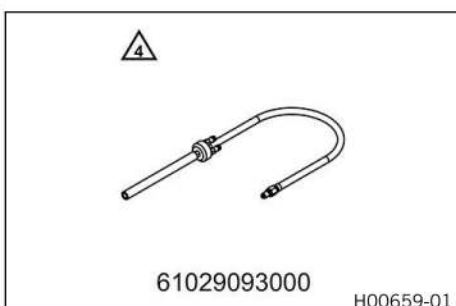

Art. no.: 61029093000

61029093000

H00659-01

## Pressure tester

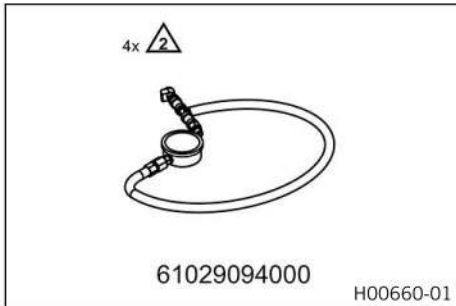

Art. no.: 61029094000

## Retaining adapter

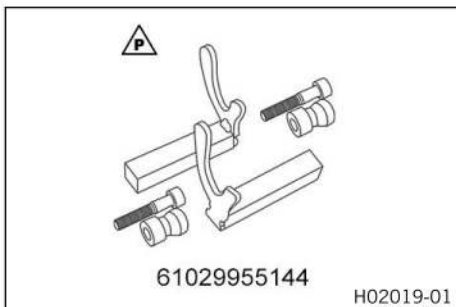

Art. no.: 61029955144

## Engine assembly stand

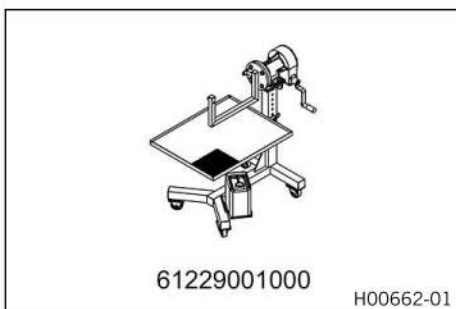

Art. no.: 61229001000

## Engine fixing arm

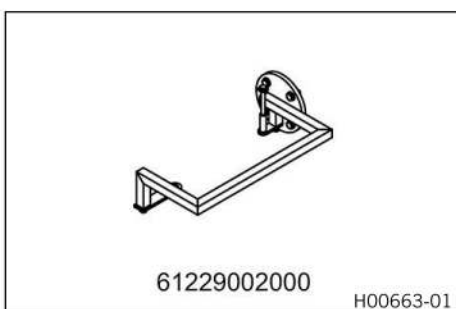

Art. no.: 61229002000

## Pressure piece

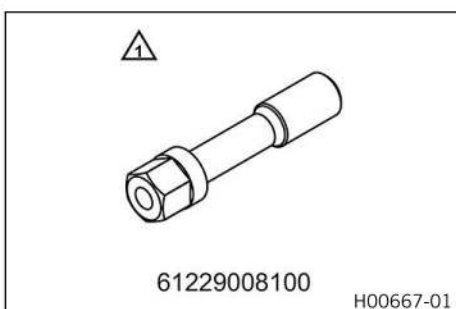

Art. no.: 61229008100

### Feature

30... 20 mm (1.18... 0.79 in)

## Extractor

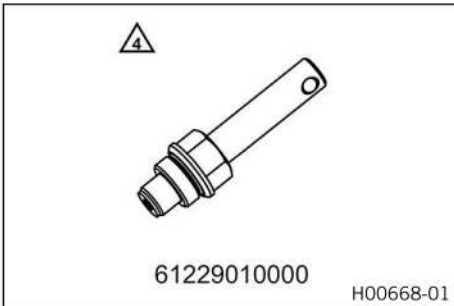

Art. no.: 61229010000

## Press drift

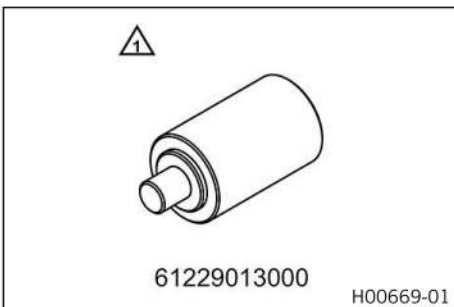

Art. no.: 61229013000

## Engine blocking screw

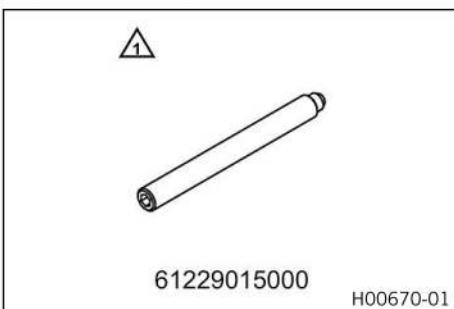

Art. no.: 61229015000

## Pressure bell

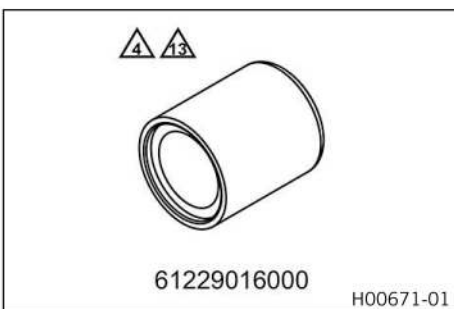

Art. no.: 61229016000

## Arms for extractor 78029033100

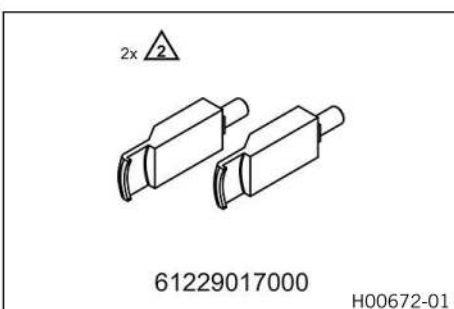

Art. no.: 61229017000

## Pressure piece

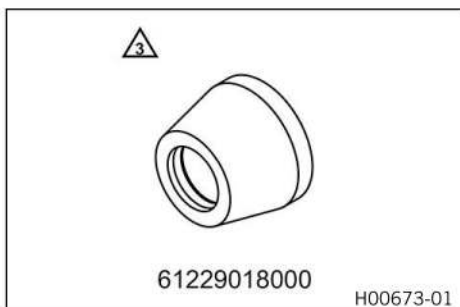

Art. no.: 61229018000

## Release device for timing chain tensioner

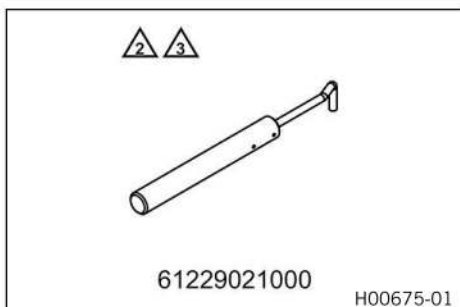

Art. no.: 61229021000

## Hex key bit

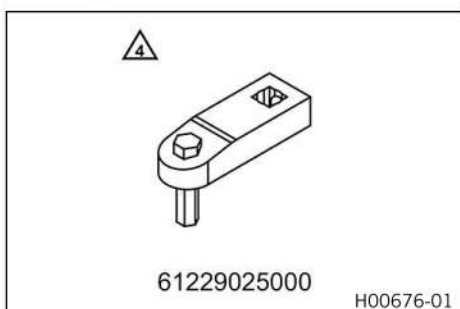

Art. no.: 61229025000

## Mounting tool for lock ring

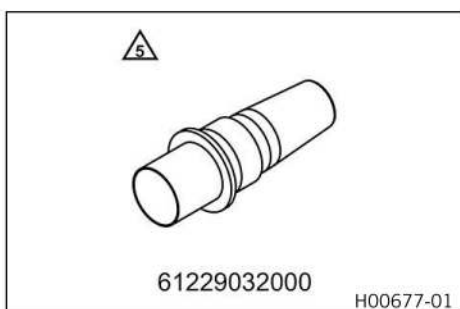

Art. no.: 61229032000

## Oil nozzle assembly tool

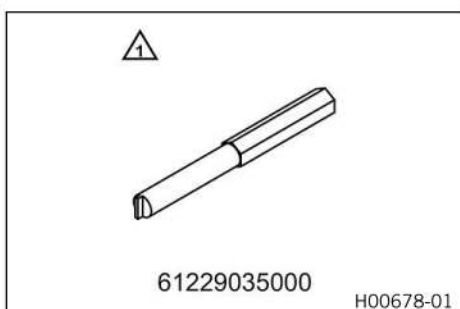

Art. no.: 61229035000



## Press drift/press sleeve

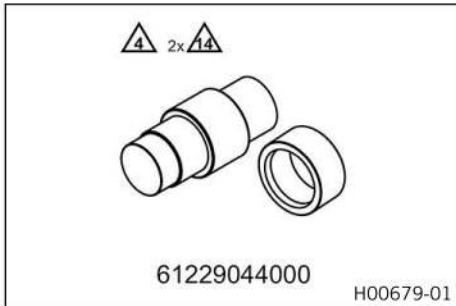

Art. no.: 61229044000

## Press sleeve

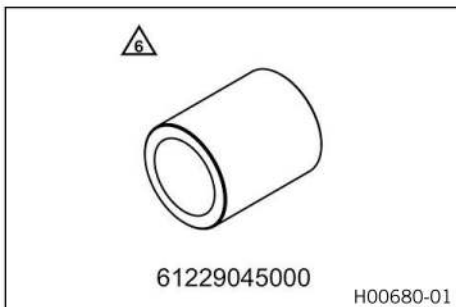

Art. no.: 61229045000

## Press drift, swingarm bearing

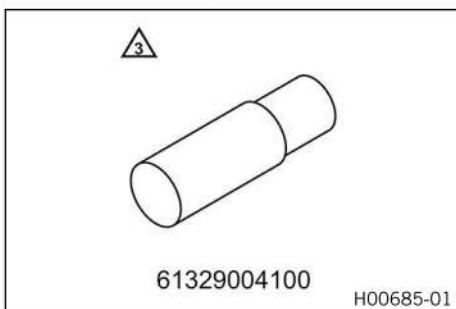

Art. no.: 61329004100

## Counterholder, swingarm bearing

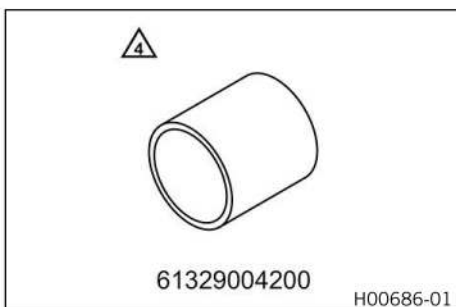

Art. no.: 61329004200

## Piston assembly ring

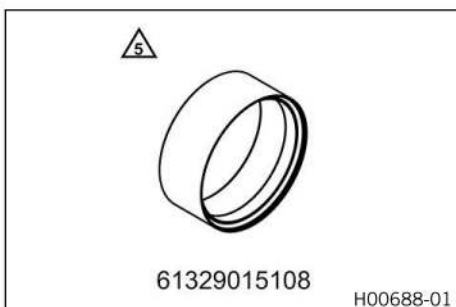

Art. no.: 61329015108

## Spread transmission locking pin

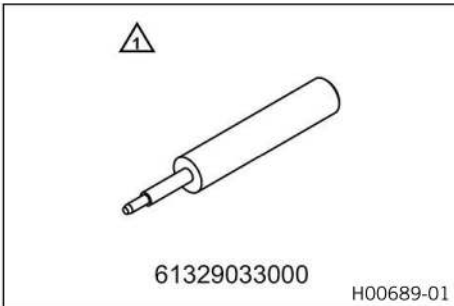

Art. no.: 61329033000

## Spread transmission fixture

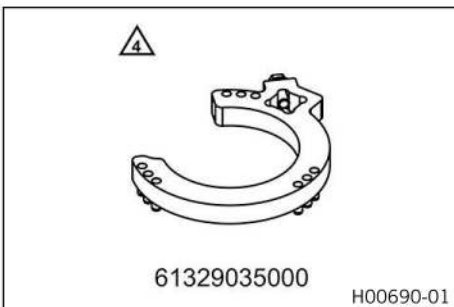

Art. no.: 61329035000

## Floor jack attachment

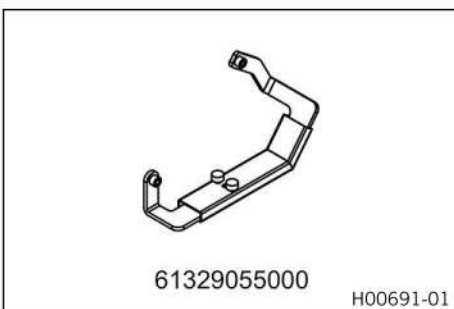

Art. no.: 61329055000

## Lifting gear, rear

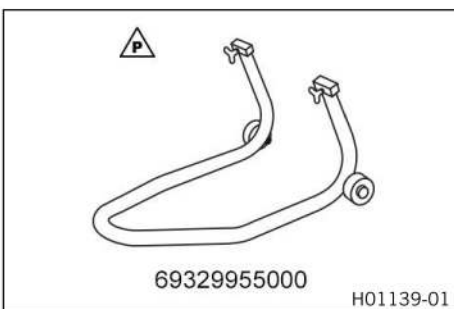

Art. no.: 69329955000

## Lifting gear, front

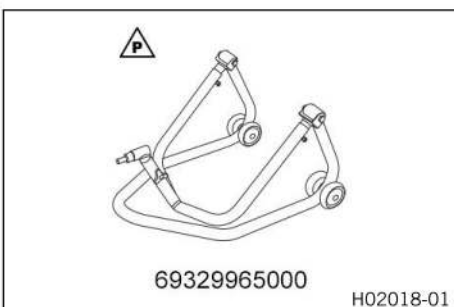

Art. no.: 69329965000

## Mounting pin

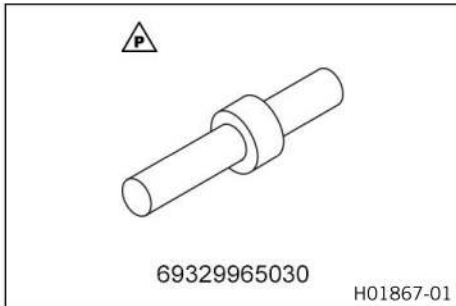

Art. no.: 69329965030

## Extractor

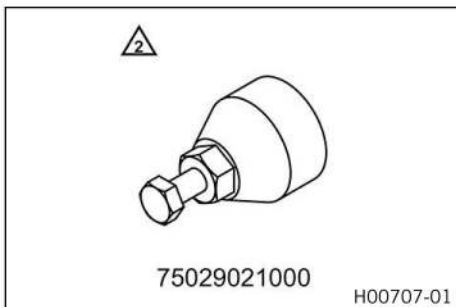

Art. no.: 75029021000

## Insertion tool for piston ring lock

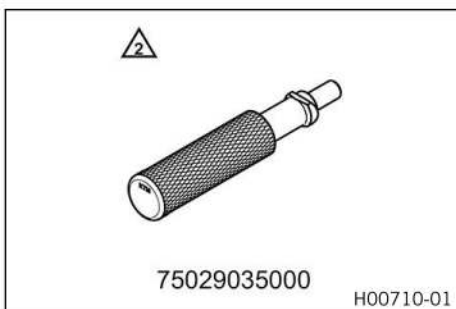

Art. no.: 75029035000

## Spark plug wrench

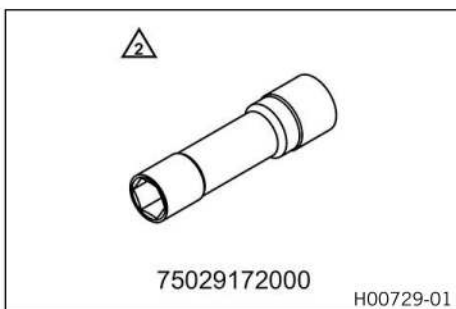

Art. no.: 75029172000

## Spark plug wrench

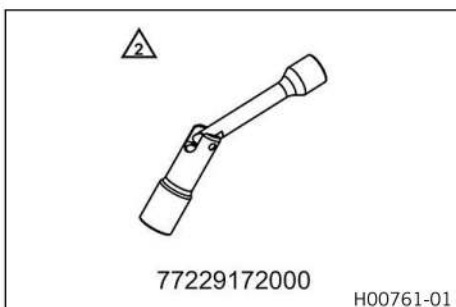

Art. no.: 77229172000

## Oil pressure adapter

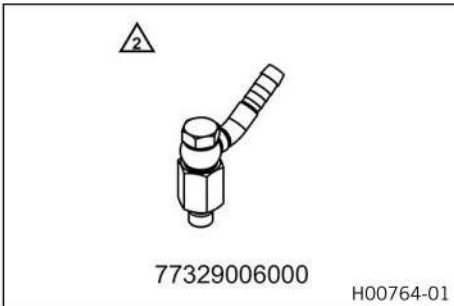

Art. no.: 77329006000

## Puller, 2-arm

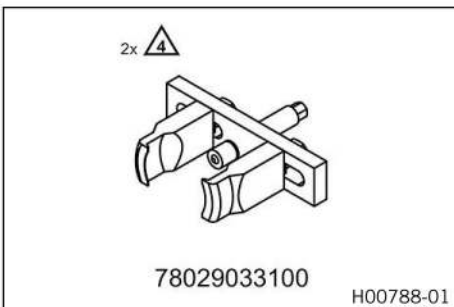

Art. no.: 78029033100

## Insert for valve spring lever

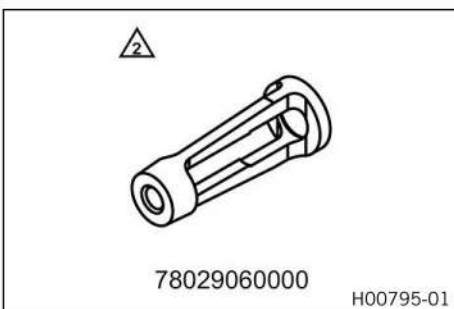

Art. no.: 78029060000

## XC\_1 NG (DE)



Art. no.: 00029196000DE

## XC\_1 NG (EN)



Art. no.: 00029196000EN

## XC\_1 NG (ES)



Art. no.: 00029196000ES

## XC\_1 NG (FR)



Art. no.: 00029196000FR

## XC\_1 NG (IT)



Art. no.: 00029196000IT

## XC\_1 NG (JP)



Art. no.: 00029196000JP

## XC\_1 NG (US)

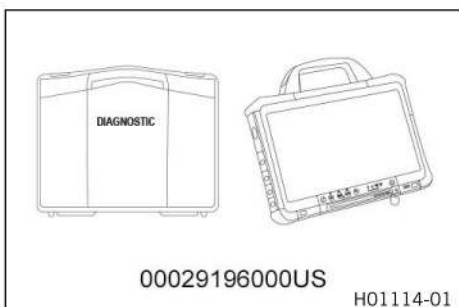

Art. no.: 00029196000US

## Pin wrench

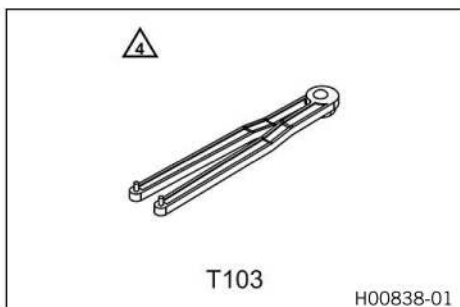

Art. no.: T103

## Pin

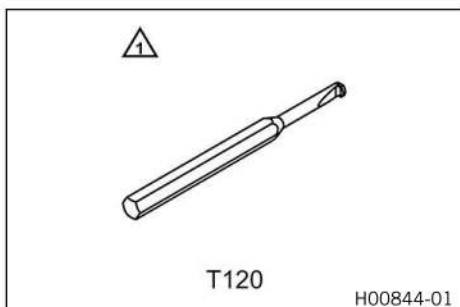

Art. no.: T120

## Pressing tool

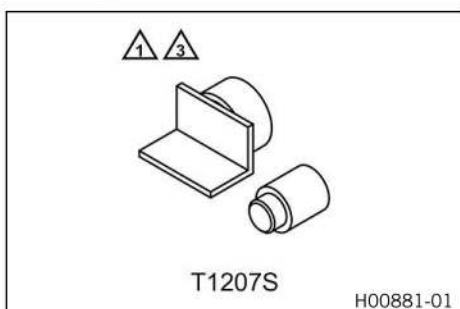

Art. no.: T1207S

## Protecting sleeve

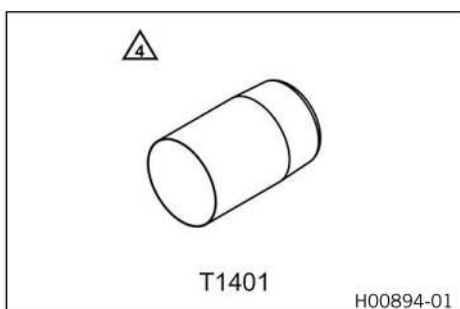

Art. no.: T1401

## Clamping stand

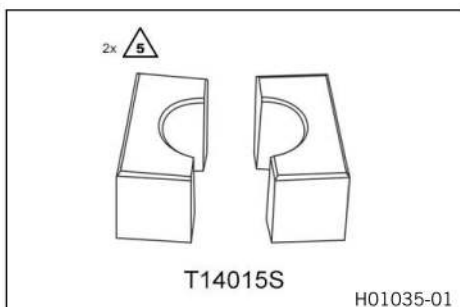

Art. no.: T14015S

## Clamping stand

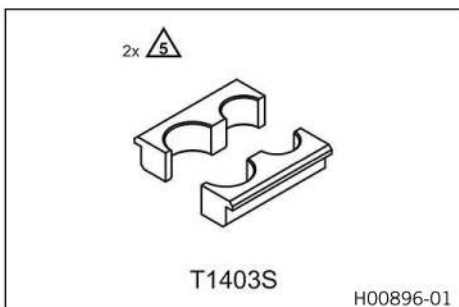

Art. no.: T1403S

## Mounting tool

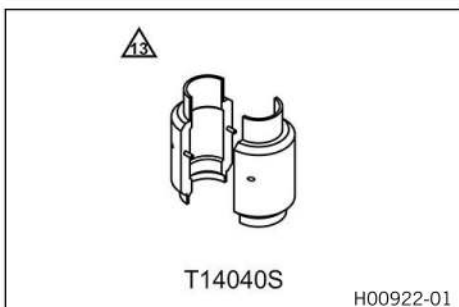

Art. no.: T14040S

## Spring compressor

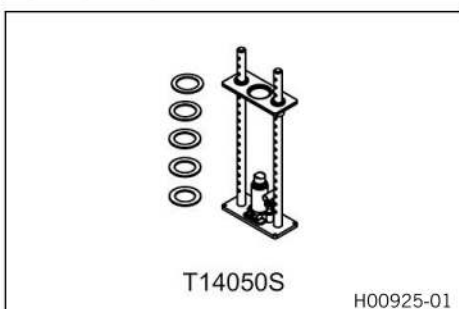

Art. no.: T14050S

## Special socket

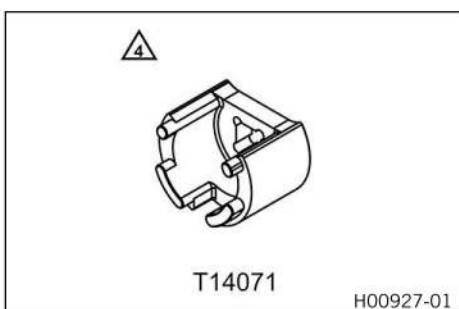

Art. no.: T14071

## JASO T903 MA

Different technical development directions required a separate specification for 4-stroke motorcycles – the **JASO T903 MA** standard. Earlier, engine oils from the automobile industry were used for 4-stroke motorcycles because there was no separate motorcycle specification.

Whereas long service intervals are demanded for automobile engines, the focus for motorcycle engines is on high performance at high engine speeds.

In most motorcycle engines, the transmission and the clutch are lubricated with the same oil.

The **JASO MA** standard meets these special requirements.

## SAE

The SAE viscosity classes were defined by the Society of Automotive Engineers and are used for classifying oils according to their viscosity. The viscosity describes only one property of oil and says nothing about quality.



<b>A</b>	
<b>Accessories</b> .....	8
<b>Air filter</b>	
changing .....	66
<b>Alternator</b>	
stator winding, checking .....	282
<b>Antifreeze</b>	
checking .....	255
<b>Assembling the engine</b>	
alternator cover, installing .....	230
balancer shaft, installing .....	227
clutch discs, installing .....	224
crankshaft, installing .....	219
engine bracket, mounting .....	241
engine, removing from the engine assembly stand .....	241
force pump, installing .....	221
front camshafts, installing .....	236
front cylinder head, installing .....	236
front piston, installing .....	234
front valve clearance, adjusting .....	239
front valve clearance, checking .....	238
gear position sensor, installing .....	227
heat exchanger, installing .....	237
idler and timing chain on the left, installing .....	228
idler and timing chain on the right, installing .....	225
ignition pulse generator, installing .....	230
ignition top dead center of the front cylinder, setting ..	234
ignition top dead center of the rear cylinder, setting ..	223
Installing the torque limiter .....	229
left engine case, installing .....	219
left suction pump, installing .....	222
locking lever, installing .....	221
middle suction pump, installing .....	219
oil drain plug, installing .....	241
oil filler tube, installing .....	239
oil filter, installing .....	228
oil spray tube, installing .....	218
rear camshafts, installing .....	233
rear cylinder head, installing .....	232
rear piston, assembling .....	230
rear valve clearance, adjusting .....	238
rear valve clearance, checking .....	238
shift drum locating, installing .....	221
shift shaft, installing .....	221
starter motor, installing .....	238
timing chain rails of the left engine case section, installing .....	217
timing chain rails of the right engine case section, installing .....	217
transmission shaft, installing .....	218
water pump wheel, installing .....	226
<b>Auxiliary substances</b> .....	8
<b>B</b>	
<b>Battery</b>	
connecting .....	127
disconnecting .....	126
installing .....	125
recharging .....	128

removing .....	125
<b>Brake disc</b>	
rear brake, changing .....	114
<b>Brake discs</b>	
checking .....	106
front brake, changing .....	107
<b>Brake fluid</b>	
front brake, adding .....	136
front brake, changing .....	137
rear brake, adding .....	142
rear brake, changing .....	143
<b>Brake fluid level</b>	
front brake, checking .....	136
rear brake, checking .....	142
<b>Brake linings</b>	
front brake, changing .....	134
front brake, checking .....	134
rear brake, changing .....	139
rear brake, checking .....	139
<b>C</b>	
<b>Camshafts</b>	
of the front cylinder, disassembling .....	273
of the front cylinder, installing .....	273
of the rear cylinder, disassembling .....	271
of the rear cylinder, installing .....	272
<b>Capacity</b>	
coolant .....	258, 300
engine oil .....	167, 277, 300
fuel .....	300
<b>Chain</b>	
checking .....	116
cleaning .....	117
opening .....	120
riveting .....	120
<b>Chain tension</b>	
adjusting .....	115
checking .....	115
<b>Charging voltage</b>	
checking .....	132
<b>Chassis number</b> .....	9
<b>Clutch</b>	
fluid level, checking/rectifying .....	244
fluid, changing .....	244
<b>Clutch lever</b>	
basic position, adjusting .....	31
<b>Coolant</b>	
draining .....	256
refilling .....	257
<b>Coolant level</b>	
checking .....	255
compensating tank, checking .....	254
compensating tank, correcting .....	254
<b>Cooling system</b>	
bleeding .....	257
<b>Cornering light</b>	
light range, adjusting .....	149
setting, checking .....	148

**Crash bar**

installing ..... 32  
 removing ..... 32

**Cruise control system**

programming ..... 152

**D**

**Disassembling the engine**

alternator cover, removing ..... 176  
 balancer shaft, removing ..... 179  
 clutch cover, removing ..... 181  
 clutch discs, removing ..... 181  
 crankshaft, removing ..... 185  
 drive wheel of the balancer shaft, removing ..... 179  
 engine bracket, removing ..... 170  
 engine oil, draining ..... 170  
 engine, clamping into the engine assembly stand ... 170  
 force pump, removing ..... 183  
 front camshafts, removing ..... 175  
 front cylinder head, removing ..... 175  
 front piston, removing ..... 176  
 front timing chain tensioner, removing ..... 174  
 gear position sensor, removing ..... 179  
 heat exchanger, removing ..... 172  
 idler and timing chain on the left, removing ..... 177  
 idler and timing chain on the right, removing ..... 183  
 ignition pulse generator, removing ..... 177  
 ignition top dead center of the front cylinder, setting .. 174  
 ignition top dead center of the rear cylinder, setting the engine ..... 171  
 left engine case, removing ..... 185  
 left suction pump, removing ..... 179  
 locking lever, removing ..... 184  
 middle suction pump, removing ..... 185  
 oil filler tube, removing ..... 172  
 oil filter, removing ..... 178  
 oil spray tube, removing ..... 187  
 primary gear, removing ..... 183  
 rear camshaft, removing ..... 173  
 rear cylinder head, removing ..... 173  
 rear piston, removing ..... 174  
 rear timing chain tensioner, removing ..... 172  
 Removing the torque limiter ..... 177  
 shift drum locating, removing ..... 184  
 shift shaft, removing ..... 184  
 starter motor, removing ..... 172  
 timing chain rails of the left engine case section, removing ..... 187  
 timing chain rails of the right engine case section, removing ..... 187  
 transmission shaft, removing ..... 186  
 valve cover, front, removing ..... 171  
 valve cover, rear, removing ..... 171  
 water pump wheel, removing ..... 180

**Drivetrain kit**

changing ..... 121

**E**

**Engine**

ignition top dead center of the front cylinder, setting .. 169  
 ignition top dead center of the rear cylinder, setting .. 169  
 installing ..... 160

preparing for clamping in the engine assembly stand .. 168  
 preparing for installation ..... 168  
 removing ..... 154

**Engine - Work on individual parts**

clutch cover ..... 196  
 clutch, checking ..... 208  
 conrod bearing ..... 194  
 countershaft, assembling ..... 214  
 countershaft, disassembling ..... 212  
 cylinder head ..... 200  
 cylinder head, checking ..... 203  
 cylinder, checking/measuring ..... 198  
 electric starter drive, checking ..... 216  
 freewheel, checking ..... 217  
 left engine case section ..... 191  
 left main bearing, installing ..... 193  
 left main bearing, removing ..... 193  
 lubrication system, checking ..... 207  
 main bearing shells, selecting ..... 190  
 main bearing, right, removing ..... 189  
 main shaft, assembling ..... 214  
 main shaft, disassembling ..... 211  
 oil pressure regulator valve, checking ..... 207  
 piston ring end gap, checking ..... 200  
 piston, checking/measuring ..... 199  
 piston/cylinder mounting clearance, checking ..... 200  
 radial clearance of the bottom connecting rod bearing, checking ..... 197  
 right engine case section ..... 187  
 right idler ..... 205  
 right main bearing, installing ..... 190  
 shift mechanism, checking ..... 209  
 shift shaft, preassembling ..... 210  
 timing assembly, checking ..... 205  
 timing chain tensioner for installation, preparing ..... 206  
 transmission, checking ..... 213

**Engine - work on the individual parts**

pretensioning the spread transmission ..... 206

**Engine – work on the individual parts**

crankshaft, support bearing, changing ..... 197  
 main shaft axial play, measuring ..... 216

**Engine – working on the individual parts**

clutch, checking ..... 245

**Engine assembly**

drive wheel of the balancer shaft, installing ..... 227  
 front valve cover, installing ..... 240  
 installing the clutch basket ..... 223  
 installing the clutch cover ..... 225  
 Installing the front timing chain tensioner ..... 237  
 installing the primary gear ..... 223  
 Installing the rear timing chain tensioner ..... 233  
 rear valve cover, installing ..... 240  
 rotor, installing ..... 229

**Engine disassembly**

removing the clutch basket ..... 182  
 rotor, removing ..... 177

**Engine guard**

installing ..... 43  
 removing ..... 43

**Engine number** ..... 10

**Engine oil**

- adding ..... 278
- changing ..... 276

**Engine oil level**

- checking ..... 276

**Engine oil pressure**

- checking ..... 279

**Engine sprocket**

- checking ..... 116

**F**

**Figures** ..... 8

**Foot brake lever**

- basic position, adjusting ..... 141

**Footrests**

- adjusting ..... 42

**Fork**

- dust boots, cleaning ..... 14

**Fork legs**

- assembling ..... 21
- checking ..... 20
- disassembling ..... 17
- fork service, performing ..... 16
- installing ..... 15
- removing ..... 14

**Fork part number** ..... 10

**Fork service, performing** ..... 16

**Frame**

- checking ..... 44

**Front fender, front**

- installing ..... 94
- removing ..... 94

**Front rider's seat**

- adjusting ..... 71
- mounting ..... 71
- removing ..... 71

**Front wheel**

- installing ..... 100
- removing ..... 99

**Fuel filter**

- changing ..... 80

**Fuel pressure**

- checking ..... 76

**Fuel pump**

- changing ..... 77

**Fuel tank**

- installing ..... 74
- removing ..... 73

**Fuses**

- in fuse box, changing ..... 130

**G**

**Gear position sensor**

- changing ..... 251
- programming ..... 253

**H**

**Hand brake lever**

- basic position, adjusting ..... 139

**Handlebar position**

- adjusting ..... 31

**Headlight**

- headlight range, adjusting ..... 149
- setting, checking ..... 148

**Headlight mask with headlight**

- installing ..... 145
- removing ..... 145

**Heated grips**

- changing ..... 36

**High beam bulb**

- changing ..... 147

**I**

**Ignition key**

- activating/deactivating ..... 150

**Initialization run**

- executing ..... 294

**K**

**Key number** ..... 9

**L**

**Low beam bulb**

- changing ..... 146

**Lower part of the air filter box**

- installing ..... 69
- removing ..... 68

**Lower triple clamp**

- installing ..... 26
- removing ..... 25

**M**

**Main fuse**

- changing ..... 129

**Main silencer**

- disassembling ..... 60
- installing ..... 60

**Manifold**

- installing ..... 63
- removing ..... 61

**Mask spoiler**

- installing ..... 92
- removing ..... 90

**Motorcycle**

- cleaning ..... 305
- lifting with front lifting gear ..... 11
- raising with the rear lifting gear ..... 11
- removing the rear from the lifting gear ..... 12
- taking from the front lifting gear ..... 11

**O**

**Oil circuit** ..... 275

**Oil filter**

- changing ..... 276

**Oil nozzle for clutch lubrication**  
 checking/cleaning ..... 280  
 installing ..... 281  
 removing ..... 280

**Oil screens**  
 cleaning ..... 276

**Operating substances** ..... 8

**P**

**Passenger seat**  
 mounting ..... 72  
 removing ..... 72

**Preparing for use**  
 after storage ..... 307  
 checks and maintenance measures when preparing for use ..... 307

**R**

**Rear hub rubber dampers**  
 changing ..... 118  
 checking ..... 118

**Rear sprocket**  
 checking ..... 116

**Rear sprocket carrier bearing**  
 changing ..... 119

**Rear wheel**  
 installing ..... 108  
 removing ..... 107

**Rider footrests** ..... 42

**Rim run-out**  
 checking ..... 98

**S**

**SAS membrane**  
 changing ..... 242

**Service schedule** ..... 309-310

**Shift lever**  
 basic position, adjusting ..... 251  
 basic position, checking ..... 251

**Shock absorber**  
 heim joint, installing ..... 50  
 heim joint, removing ..... 50  
 installing ..... 47  
 removing ..... 46  
 spring pretension, adjusting ..... 45  
 spring, installing ..... 49  
 spring, removing ..... 48  
 static sag, checking ..... 45

**Shock absorber article number** ..... 10

**Shock absorber control motor**  
 teaching ..... 59

**Side cover, front**  
 removing ..... 87

**Side cover, front,**  
 installing ..... 87

**Spare parts** ..... 8

**Spark plugs**  
 changing ..... 284

**Spoke tension**  
 checking ..... 99

**Spring**  
 installing ..... 19  
 removing ..... 19

**Starting** ..... 13  
 for checking the function ..... 13

**Steering damper item number** ..... 10

**Steering dampers**  
 changing ..... 29

**Steering head bearing**  
 changing ..... 28  
 lubricating ..... 25

**Steering head bearing play**  
 adjusting ..... 24  
 checking ..... 24

**Storage** ..... 307

**Swing angle sensor**  
 teaching ..... 59

**Swingarm**  
 checking ..... 51  
 installing ..... 57  
 removing ..... 52

**Swingarm bearing**  
 changing ..... 54  
 checking ..... 51

**T**

**Tank cover**  
 installing ..... 89  
 removing ..... 89

**Technical data**  
 capacities ..... 300  
 chassis ..... 301  
 chassis tightening torques ..... 302  
 electrical system ..... 301  
 engine - tolerance, wear limits ..... 296  
 engine tightening torques ..... 299  
 fork ..... 302  
 shock absorber ..... 302  
 tires ..... 302

**Throttle grip**  
 changing ..... 33

**Throttle valve body**  
 installing ..... 293  
 removing ..... 292

**Tire air pressure**  
 checking ..... 97

**Tire air pressure sensor**  
 programming ..... 99

**Tire condition**  
 checking ..... 97

**Tire pressure sensor**  
 changing the front tire pressure sensor ..... 105  
 changing the rear tire pressure sensor ..... 113

**Triple clamp cover, bottom**  
 installing ..... 93

removing	93
<b>Tubeless tire system</b>	103
changing the front tubeless sealing profile	103
changing the rear tubeless sealing profile	111
<b>Type label</b>	9
<b>U</b>	
<b>Upper part of the air filter box</b>	
installing	67
removing	66
<b>V</b>	
<b>Valve clearance</b>	
checking	259
checking (air filter and spark plugs removed)	267
of the front cylinder, setting	271
of the rear cylinder, setting	270
<b>Vehicle</b>	
raising with the center stand	12
removing from the center stand	12
<b>W</b>	
<b>Warranty</b>	8
<b>Wheel bearing</b>	
checking	98
of the front wheel, changing	101
of the rear wheel, changing	109
<b>Wind shield</b>	
adjust the adapter position	95
adjusting	95
installing	95
removing	94
<b>Winter operation</b>	
checks and maintenance steps	306
<b>Wiring diagram</b>	312-337
page 01 of 13	312
page 02 of 13	314
page 03 of 13	316
Page 04 of 13	318
Page 05 of 13	320
Page 06 of 13	322
Page 07 of 13	324
Page 08 of 13	326
Page 09 of 13	328
Page 10 of 13	330
Page 11 of 13	332
Page 12 of 13	334
Page 13 of 13	336
<b>Work rules</b>	7

**READY TO RACE**

>> [www.ktm.com](http://www.ktm.com)



3206220en

01/2017



**KTM**

**KTM Sportmotorcycle GmbH**  
5230 Mattighofen/Austria  
<http://www.ktm.com>



Photo: Mitterbauer/KTM